



POF-1262  
(FOREIGN SUPPLIES)

GOVERNMENT OF PAKISTAN  
PAKISTAN ORDNANCE FACTORIES  
TENDER ENQUIRY

To

Dear Sirs,

Reference: Tender Enquiry NO. **POF-5226-FP-Capt (5)-Pur-Gdl DATED 13.01.2025**. Offers should be sent duly sealed in an envelope. Please note the following instructions for filling the tender:-

1. **SUBMISSION OF TENDER**

- 1.1 Tenders will be opened at **09:30** hours on **27.02.2025** and must reach at Bid Centre POF Wah Cantt on or before **09:00 hours** on same date. The tender received late will not be entertained. You may witness the opening of the tender if you so desire. If a representative is deputed, he should bring a letter of authority from you.
- 1.2 Only one tender should be included in one envelope. The outside of the envelope should be inscribed with:-

Tender Enquiry No: **POF-5226-FP-Capt (5)-Pur-Gdl, DATED 13.01.2025**  
Tender to be opened on: **27.02.2025 on 09:30 hrs**

Address as follows:- **Incharge Bid Centre**  
**Adjacent to Rabita Hall**  
**POF Wah Cantt**

- 1.3 If envelop do not indicate reference of TEs or received late, the same will be returned un opened.

2. **GENERAL INSTRUCTIONS REGARDING PREPARATION OF QUOTATIONS**

T.E will be opened as per PPRA Rule 36(d) i.e., Two stage, two envelope method. Case would be processed as per PPRA Rules / POF Purchase Procedure and contract would be awarded to most Advantageous Bidder on the basis of **Bid Qualification Criteria (Annex-B)**.

- 2.1 **For Plant and Machinery**, you are required to quote in two parts:-

**Part-I: "Technical Offer"** It should exclusively give technical details and literature / brochures of the offered plant, machinery & equipment, validity date, delivery schedule and signed undertaking given on the schedule to this tender enquiry. It must not indicate price, costs etc. Country of origin should be clearly mentioned.

**Part-II: "Commercial Offer"** It should indicate the commercial terms e.g. price, terms of payment, mode of payment, mode of supply.

**Each part should be placed in a separate sealed cover. The envelopes should be inscribed with Part-I "Technical Quotation without price" & Part-II "Commercial Quotation with price".**

- 2.2 The quotation must remain valid for, at least 180 days (extendable) from the date of opening of commercial offer.

Contd....P/2

- 2.3 The quotation should hold good for any reduced quantities without notice.
- 2.4 In the event of non-acceptance of offer, intimation may be given to the Tenderers on their request.
- 2.5 Conditional offers or alternative offers are likely to be ignored.
- 2.6 Quotations should be based on FOB / C&F. The freight should be indicated separately. Insurance premium should not be included in the quoted price. However, where insurance is considered necessary, advice to that effect should be given in the quotation.
- 2.7 Submission of the offer through an agent in Pakistan should be avoided. In case it is considered inevitable, the agent's quotation must invariably be accompanied by the original Proforma Invoice from the principals/ manufacturers.
- 2.8 Country of origin and port of shipment to be stated.
- 2.9 Supplier will render necessary information regarding hazardous effects on environment, of the materials/products supplied by them along with shipping/ dispatch documents.
- 2.10 The supplier will furnish a declaration regarding Fees, Commission & Brokerage etc payable by the firm along with shipping documents.
- 2.11 If the requisite information is not furnished on the TE form or offer received is not in conformity with the requirement of the TE each offer should be ignored.

3. **Pre-shipment Inspection (PSI)**

- 3.1 PSI of machine at firm's premises will be conducted by 03 x POF Engineers for 01 x week.
- 3.2 PSI will include demo of all functions of machine, accuracy and test run of machine for production of 100 components proving performance and cutting cycle time
- 3.3 Boarding & lodging including food expenses, return air tickets and daily allowance (DA) per person per day will be borne by POF.
- 3.4 Dispatch of components, materials/gauges to carry out trial run at firm's premises will be the sole responsibility of firm through local rep/ foreign contractor at their own arrangement / expense.

4. **Training**

- 4.1 Supplier will provide free of cost training for 02 weeks for 05 x POF engineers/Technicians on programming, operating and maintenance at manufacturer's premises on the machine.
- 4.2. Boarding & lodging including food expenses, return air tickets and daily allowance (DA) per person per day will be borne by POF.
- 4.3 During training, 200 components as per attached drawing will be manufactured on continuous run.

5. **INSTALLATION & COMMISSIONING & FAT (Final Acceptance Test)**

- 5.1 Installation & commissioning of machine at POF Gadwal shall be responsibility of supplier.
- 5.2 Machine will be continuously run for production of 100 components.
- 5.3 FAT certificate will be issued after successful demo of all functions, test run, proving of accuracy and cycle time.
- 5.4. Boarding & lodging including food expenses and return air tickets will be borne by supplier.

6. **LITERATURE REQUIRED**

- 04 x sets of following documents in **English language** are required:
- 6.1 Schematic diagram of each PCB
  - 6.2 Control unit diagram

- 6.3 Electric & control circuit of machine
- 6.4 Details of motors and their control.
- 6.5 Operating, maintenance and service manual (04 each).
- 6.6 Spec of recommended cutting oil, coolant, hydraulic oil and lubricant.

**7. ADDITIONAL EQUIPMENTS (Item wise prices should be quoted separately)**

- 7.1 Indexable clamping device for clamping and sawing round billets - Qty: 01
- 7.2 Blade Shear assemblies. - Qty: 01
- 7.3 Saw blade Butt welding unit with annealing device and grinding wheel - Qty: 01
- 7.4 Saw dust collection system - Qty: 01
- 7.5 Band saw wheels each upper & lower - Qty: 01 each
- 7.6 Band saw wheel linings for upper and lower wheels - Qty 06
- 7.7 Adhesive and hardening agent for band saw wheel lining - Qty 06
- 7.8 Maintenance kit trolley (150 pieces) including wheel tire change kit - Qty 02
- 7.9 BI METAL Saw band welded - Qty 03
- 7.10 Carbide tipped saw band welded - Qty 03

**8 Spare Parts (Item wise prices should be quoted separately)**

- 8.1 Machine OEM to supply electrical and mechanical spare parts for 5000 operating hrs.
- 8.2 Complete list with price is required as part of quotation.
- 8.3 Spares finalized by the purchaser will be part of contract.
- 8.4 Spare parts list will be negotiable during PSI, subject to total amount remaining equal to that finalized in contract.

Note: Surety for availability of spares for minimum 10 years is required.

**9. Setting of Machine on test piece**

- 9.1 OEM will design and deliver with machine, the indexable clamping device for sawing of POF provided test component as per **sketch No. GDL/4**. Raw material for component will be provided by POF, however the same will be dispatched to firm's premises through local rep / foreign contractor at their own arrangement / expense.
- 9.2 Test piece will be 333mm longer and 133.2mm round billet.
- 9.3 Test piece is required to be saw into three pieces at 120 degrees
- 9.4 Assessment of the machine performance during training, PSI and installation/commissioning will be based on manufacturing of POF desired component.

**10 Cycle Time of Operation**

- 10.1 Minimum production of 20~25 components is essentially required in 06 hours
- 10.2 OEM will work out and provide machine floor to floor cycle time study with technical offer.

**11. Warranty / Guaranty Certificate**

- 11.1 The Supplier will render Warranty/Guarantee certificate in duplicate to the Purchaser as soon as machine has been dispatched/delivered.
- 11.2 This Warranty/Guarantee shall be binding on the Supplier for a period of 12 months reckoning from the date of final acceptance certificate after installation/commissioning of machine.
- 11.3 In case the equipment on checking / test after receipt at consignee's ware-house, is found not conforming strictly to the relevant specifications and other particulars or becomes faulty during operation in warranty period, the Supplier shall immediately replace the rejected/ faulty equipment by acceptable equipment free of cost and without obligation to the Purchaser

Contd....P/4

13. **ACCEPTANCE OF OFFERS**

The right to accept or reject any offer in full or in part is hereby reserved. However, rejection grounds shall be intimated to the tenderer upon request.

14. **Payment Terms**

- 14.1 Payment will be made by means of an irrevocable Letter of credit.
- 14.2 70% payment against shipping documents & acceptance report by PSI team of consignee as well as issuance of PSI Acceptance Certificate by the purchaser /consignee.
- 14.3 30% payment after successful commissioning of machine at purchaser premises against issuance of FAT certificate by the consignee on successful trial run and receipt and acceptance of all deliverables (spares/ tooling, accessories / lubricants, software, manuals / standards / catalogues etc.)

All Bank charges incurred in Pakistan in connection with the establishment of L.C. will be borne by the Purchaser, whereas all Bank charges incurred in connection with drawing of payment including charges for confirmation of L.C. by the advising Bank/Foreign Bank will be borne by the Supplier.

15. **Tender Fee**:- The tender must be accompanied by a non-refundable fee by means of a cross postal order / pay order for Rs 500/- in favor of Director Admin POFs Wah Cantt.

16. **Bid Security**

- 16.1 A copy of Bid Security should accompany the tender in shape of deposit at call receipt / Pay Order / Banker Cheque from scheduled bank drawn in favour of:-  
**GM-PP&C-POF Gdl**
- 16.2 Bid security instrument in original must be provided on the day / date of tender opening in Bid Centre as under:-
- Registered / indexed firms – 2% of quoted value subject to the maximum ceiling of Rs 0.5 Mn.
  - Registered / un-indexed firms - 3% of quoted value subject to the maximum ceiling of Rs 0.75 Mn.
  - Un-Registered firms - 5% of quoted value subject to the maximum ceiling of Rs 1.00 Mn.
  - State owned organizations are not required to provide Bid Security.
  - Bid money will be returned to unsuccessful (less first three lowest quote firms) bidders on opening of commercial offer.
  - Bid money will be returned to successful bidders on submission of performance bond / unconditional B.G.
  - Offers received from local bidders without Bid Security will not be entertained.
  - Bid Money will be forfeited in case the quotation is withdrawn before the expiry of its validity date.

17. **PERFORMANCE BOND**

- 17.1 The successful bidder will provide Performance Bond at the rate up to 10% F.O.B value of contract in favour of the Controller Military Accounts (CMA) POF, Wah Cantt. The Performance Bond will be furnished in the form of Deposit at Call Receipt (CDR) from any scheduled bank in Pakistan or any unconditional Bank Guarantee on prescribed proforma covered by any scheduled bank in Pakistan. The Performance Bond shall be furnished within 45 days from the date of opening of Letter of Credit. It shall be valid for a period of 12 months after FAT and receipt / acceptance of all the deliverables.
- 17.2 No Performance Bond will be required if the total value of the contract is less than US\$ 50,000 and contract is placed directly on the foreign Supplier.
- 17.3 If the supplier fails to furnish the Performance Bank Guarantee within specified time, such failure will constitute a breach of contract and Purchaser shall be entitled to make other arrangements for purchase of the store at the risk and expense of the supplier.

Contd....P/5

18 **FAILURE TO SUPPLY THE STORES**

All deliveries must be completed by the specified date. If the failure to deliver the stores within the scheduled time should have arisen from "Force Majeure", which the Purchaser may admit as reasonable ground for further time, he will allow such additional time as he may consider to have been required by the circumstances of the case. Otherwise, he will be entitled, at his discretion, to cancel the contract; and/or, claim liquidated damages upto 2% but not less than 1% of the contact price of the items and their quantities for each and every month, beyond the specified delivery date, during which these may not be delivered, subject to a maximum of 10% of the total contract value; or, to purchase from elsewhere, the unsupplied stores at the risk and cost of the Supplier.

19. **SECURITY OF INFORMATION**

The tenderer and his employees must not communicate any information relating to the sale/purchase of stores under this enquiry to any person other than the manufacturer or to any press or agent not authorized in writing by POFs to receive it.

Please return the Schedule to the tender duly signed by the specified date, alongwith the specifications, drawings etc, if any, enclosed herewith even if you are unable to quote.

**Warning:** In case the firm abstain from making offer or fail to return / acknowledge the tender form by the specified date on three occasions no further tender enquiry be issued to them and their name would be liable to be removed from the approved list

Yours faithfully,

(Iftikhar Ahmad Bajwa)  
G.M-PP&C POF Gdl  
For Pakistan Ordnance Factories  
[mdgdl@pof.gov.pk](mailto:mdgdl@pof.gov.pk)

## PAKISTAN ORDNANCE FACTORIES

SCHEDULE TO TENDER ENQUIRY NO. POF-5226-FP-Capt (5)-Pur-Gdl DATED 13.01.2025

(1) FOR MATERIALS

(2) **FOR PLANT & MACHINERY:**

(1)	(2)	(3)	(4)	(5)		(6)
Item no.	Description with specs. etc.	Unit	Qty	Price per Unit FOB/C&F		Delivery Date
				In Figures	In Words	
1	Vertical Band Saw Machine Spec: As per attached Annex 'A'.	No	01			Within 06 x months from the date of opening of LC

Specifications: - **Annexure "A" (04 x pages)**(3) Special Conditions. - **Annexure "B"** (Bid Qualification Criteria)**Annexure "C"** (As per sketch No.GDL/4)(4) **Undertaking**

Should our offer be accepted, we hereby undertake to supply the stores/render the Services contracted on the basis of Conditions of contract embodied in Form POF 1280 and to deposit the performance bond within the prescribed time, failing which it will constitute a breach of contract, and POF will have the right to purchase the stores/services elsewhere at our risk and cost.

Place .....

Signature of the Tenderer.....

Date .....

Name .....

Position .....

Address .....

Income Tax G.I.R. No.....

## Vertical Band Saw Machine

### **1. MAIN FEATURES**

1.1. Throat (i.e. band to column width)	850mm minimum
1.2. Work height under guide	450mm minimum (test piece will be 333mm longer billet of dia 135mm mounted in indexable fixture to cut into pieces longitudinally)
1.3. Table Size	Length =1100 mm minimum Width = 1000 mm minimum
1.4. Table feed	0~1.8 m/min
1.5. Table feed stroke	250~300 mm
1.6. Table tilt	left = 10 degree minimum right = 40 degree minimum
1.7. Band Tension stroke i.e. wheel adjustment	minimum75 mm upper wheel adjustment
1.8. Saw band thickness	within range of 0.5 ~1.5 mm
1.9. Saw band type	Bimetal Saw band Carbide tipped Saw band
1.10. Saw band guides movement	upper guide 400 mm minimum
1.11. Saw band Speed	variable from 16 ~ 4500 m/min
1.12. Wheel Dia	900 mm minimum
1.13. Power supply	3 Phase AC 400V 50Hz 50 A
1.14. Saw motor	15 hp minimum

### **1.15. Machine Color**

a. Color should be standard RAL 6011

### **2. TECHNICAL REQUIREMENTS**

2.1. Mist Coolant System
2.2. Band Saw Tension Adjustment And Tension Indication
2.3. Infinitely Controlled Variable Table Feed With Rapid Return
2.4. Roller Guided Saw Band With Lubrication
2.5. Infinitely Controlled Variable Speed Drive With Speed Indication
2.6. Auto Wheel Brakes
2.7. Saw Band Protection Safety Guards/Shields
2.8. Safety Door Interlocks
2.9. Adjustable table stop limit switches for auto rapid return of table after cut
2.10. Work Light
2.11. Work Piece Clamping
2.12. Automatic Hydraulic Indexing Device Numerically Controlled
2.13. Built in Voltage stabilizer (input voltage 360-440 VAC )

## 2.14. Safeties

- a. All safeties for machine, operator/setters, operations, interlocking, handling, manual programming and setting must be incorporated

## 2.15. Noise Level

- a. Noise level should be according to NEQS i.e. less than 75db

## 2.16. Spec for Electric Supply System

Electric supply system must conform to following:

- a. 400 ± 5% VAC, 50 Hz, 3 Phase, 4-Wire System / 220 ± 5% VAC, 50 Hz, Single Phase
- b. All motors should be IP 54 protected
- c. Industrial electrical measuring instruments should have an accuracy of Class 0.5 or better
- d. Equipment should be earthed having stabilized power input, line protection circuit breakers with phase failure module & thermally delayed overload relays/electro-magnetic quick-acting relays, as required. It should be followed by cut-out and safety fuses to provide optimum selectivity
- e. Specifications governed by IEC will be acceptable for electrical equipments
- f. Class F insulation is required
- g. Note: Equivalent DIN Specifications are acceptable for electrical equipment

## 3. SITE & OPERATING CONDITIONS

3.1. Air Pressure available = 06 bar

3.2. Temperature variation between Winter and Summer is from 0°C to 50°C

3.3. Relative humidity varies from 15%~ 90% RH

## 4. COUNTRY OF ORIGIN

4.1. Europe, USA, UK , Turkey , Japan, South Korea or any other country manufacturing under license of OEMs from these countries

## 5. LITERATURE REQUIRED

04 x sets of following documents in **English language** are required:

5.1. Schematic diagram of each PCB

5.2. Control unit diagram

5.3. Electric & control circuit of machine

5.4. Details of motors and their control

5.5. Operating, maintenance and service manual(04 each)

5.6. Spec of recommended cutting oil , coolant , hydraulic oil and lubricant

## 6. ADDITIONAL EQUIPMENTS

(Item wise prices should be quoted)

6.1. Indexable clamping device for clamping and sawing round billets	Qty 01
6.2. Blade Shear assembly	Qty 01
6.3. Saw blade Butt welding unit with annealing device and grinding wheel	Qty 01
6.4. Saw dust collection system	Qty 01
6.5. Band saw wheels each upper & lower	Qty 01each
6.6. Band saw wheel linings for upper and lower wheels	Qty 06
6.7. adhesive and hardening agent for band saw wheel lining	Qty 06
6.8. Maintenance kit trolley (150 pieces) including wheel tire change kit	Qty 02
6.9. BI METAL Saw band welded	Qty 03
6.10. Carbide tipped saw band welded	Qty 03



**6.11. Spare Parts (Item wise prices should be quoted)**

- a. Machine OEM to supply electrical and mechanical spare parts for 5000 operating hrs
- b. Complete list with price is required as part of quotation for machine
- c. Spare parts finalized by the purchaser will be part of contract
- d. Spare parts list will be negotiable during PSI, subject to total amount remaining equal to that finalized in contract
- e. Note: Surety for availability of spares for minimum 10 years is required

**7. TERMS & CONDITIONS**

**7.1. Setting of Machine on test piece (Detail as per T.E Clause 9)**

- a. OEM will design and deliver with machine, the indexable clamping device for sawing of POF provided test component as per sketch No. GDL/4. Raw material for component will be provided by POF
- b. Test piece will be 333mm longer and 133.2mm round billet
- c. Test piece is required to be saw into three pieces at 120 degrees
- d. Assessment of the machine performance during training, PSI and installation/commissioning will be based on manufacturing of POF desired component

**7.2. Cycle Time of Operation**

- a. Minimum production of 20~25 components is essentially required in 06 hours
- b. OEM will work out and provide machine floor to floor cycle time study with technical offer

**7.3. Training**

- c. Supplier will provide free of cost training for 02 weeks for 05 x POF engineers/Technicians on operating and maintenance at manufacturer's premises on the machine
- d. During training, 200 components as per attached drawing will be mfctd. on continuous run
- e. Boarding & lodging including food expanses, return air tickets and daily allowance (DA) per person per day will be borne by POF

**7.4. Pre-shipment Inspection**

- a. PSI of machine at firm's premises will be conducted by 03 x POF Engineers for 01 x week
- b. PSI will include demo of all functions of machine , accuracy and test run of machine for production of 100 components proving performance and cutting cycle time
- c. Dispatch of components, materials/gauges to carry out trial run at firm's premises will be the sole responsibility of firm through local rep / foreign contractor at their own arrangement / expense.
- d. Boarding & lodging including food expanses, return air tickets and daily allowance (DA) per person per day will be borne by POF

**7.5. Installation/Commissioning & FAT**

- a. Installation & commissioning of machine at POF Gadwal shall be responsibility of supplier
- b. Machine will be continuously run for production of 100 components
- c. FAT certificate will be issued after successful demonstration of all functions of machine, test run, proving of accuracy and cycle time
- a. Boarding & lodging including food expanses and return air tickets will be borne by supplier

### **7.1. Warranty/Guarantee**

---

- a. The Supplier will render Warranty/Guarantee certificate in duplicate to the Purchaser as soon as machine has been dispatched/delivered
  - b. This Warranty/Guarantee shall be binding on the Supplier for a period of 12 months reckoning from the date of final acceptance certificate after installation/commissioning of machine
  - c. In case the equipment on checking / test after receipt at consignee's ware-house, is found not conforming strictly to the relevant specifications and other particulars or becomes faulty during operation in warranty period, the Supplier shall immediately replace the rejected/ faulty equipment by acceptable equipment free of cost and without obligation to the Purchaser
- 

### **7.2. Performance Bond (Detail as per T.E Clause 17)**

---

- a. Successful bidders shall provide Performance Bank Guarantee of 10% of FOB value of contract
  - b. It shall be valid for 12 months after date of satisfactory installation/commissioning and issuance of final acceptance test certificate (FAT) of the machine
- 

### **7.3. Payment Terms (Detail as per T.E Clause 14)**

---

- a. Payment will be made by means of an irrevocable Letter of credit
  - b. 70% payment against shipping documents & acceptance report by PSI team of consignee as well as issuance of PSI Acceptance Certificate by the purchaser
  - c. 30% payment after successful commissioning of machine at purchaser premises against issuance of FAT certificate by the consignee on successful trial run
-

**Bid Qualification & Selection Criteria**

Sr. No.	Technical/Commercial aspects to be considered to ease out most advantageous bid	Compliance level			Remarks
		Fully Complied	Partially Complied	Not Complied	
1.*	Bid submitted in compliance with PPRA Rule 36(d)				
2.*	Confirm to tender specification				
3.*	Confirm to tender quantity(s)				
4.	Complete technical literature/ Brochure /catalogue provided in first go along with technical bid				
5.	Prices are valid for any reduced quantity(s) without notice				
6.*	180 days bid validity from date of opening of commercial offers/bids confirmed				
7.	Delivery period as per schedule of tender enquiry confirmed				
8.	Payment terms as per tender enquiry				
9.	In case of new entrant, proof of past performance / list of identical supplies to prove capabilities in the relevant field				
10.*	Certificate regarding fulfillment of all tender requirements				
11.*	T.E Undertaking- Signed/Stamped				
12.*	Offer /bid (Tech + Comm) is un-conditional				
13.*	Complete company profile				
14.	Certificate that firm is not blacklisted or under debarment by any Govt/ Semi Govt organization				
15.	Confirmation of Performance Bond against LOI (Letter of Intent) as per T.E Clause				
16.*	Main Features as per Annex "A" of T.E				
17.*	Technical Requirements as per Annex "A" of T.E				
18.*	Site & operating conditions as per annex "A" of T.E				
19.*	Country Of Origin as per Annex "A" of T.E				
20.*	Specification for Electric Supply System as per Annex "A" of T.E				
21.*	Literature Required as per Annex "A" of T.E				
22.*	Additional Equipment as per annex "A" of T.E				
23.*	Terms & Conditions as per Annex "A" of T.E				
Note: Clause with (*) are necessary to be complied. In case of non-compliance of the same, the bid will be disqualified					

-----  
Signature of the Tenderer with stamp

Place.....

Dt: .....

**BEFORE OPERATION**

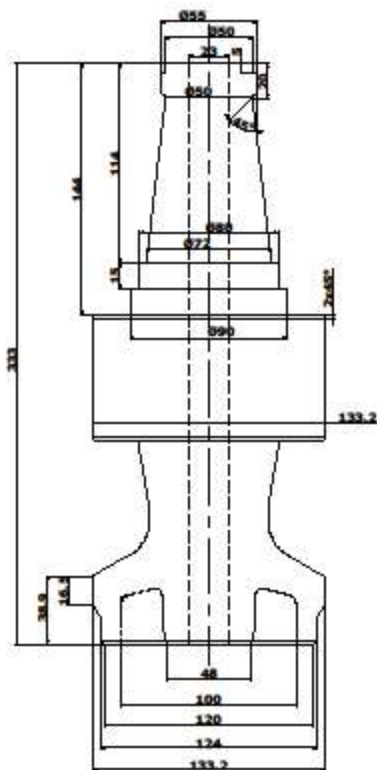

**AFTER OPERATION**

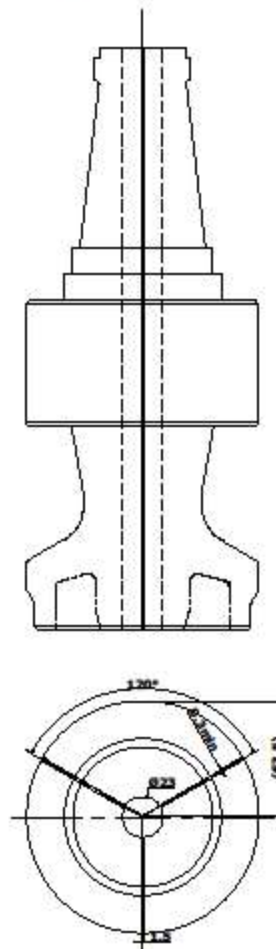

**sketch no. Gdl/4**