



GOVERNMENT OF PAKISTAN
PAKISTAN ORDNANCE FACTORIES
TENDER ENQUIRY

To

Dear Sirs,

Reference: - TENDER ENQUIRY NO. 3521-2-44-54-FP-Capt-Pur-AA, dated 22-02-2025.

You are requested to submit sealed quotations for the item noted on the Schedule to the Tender. Please note the following instructions for filling the tender:-

1. **SUBMISSION OF TENDER**

- 1.1 Tenders will be opened at 1100 hours on 10-04-2025 and must reach at Bid Centre adjacent to Rabita Hall at least half an hour earlier than the opening time on same date. You may witness the opening of the tender if you so desired. If a representative is deputed, he should bring a letter of authority from you. The tender received late will not be entertained.
- 1.2 Only one tender should be included in one envelope. The outside of the envelope should be inscribed with: -

Tender Enquiry No: 3521-2-44-54-FP-Capt-Pur-AA, dated 22-02-2025

Tender to be opened on: 10-04-2025

Address as follows:-

**BID Centre Adjacent To Rabita Hall
Managing Director
Artillery Ammunition Factory
Pakistan Ordnance Factories,
Wah Cantt, Pakistan.
Fax : 051-9314100 & 051-9271400
Email : mdaa@pof.gov.pk
gmservices-aa@pof.gov.pk**

- 1.3 If envelope do not indicate reference of TE or received late, the same will be returned un-opened.

Contd...

1.4 **EVALUATION CRITERIA.**

All the technical proposals will be evaluated / scrutinized initially and commercial Proposals of only those bidders will be opened who will be technically prequalified / accepted. Accordingly, Order / Contract will be awarded to most advantageous bidder on the basis of bid qualification criteria (Annex-E).

2. **GENERAL INSTRUCTIONS REGARDING PREPARATION OF QUOTATIONS**

2.1 For Plant & Machinery, you are required to quote in two parts:-

Part-I "TECHNICAL OFFER" It should exclusively give technical details and literatures/brochures of the offered plant, machinery and equipment; validity date; delivery schedule; and signed undertaking given on the schedule to this Tender Enquiry and country of origin should be clearly mentioned. It must not indicate price, costs etc.

Part-II "COMMERCIAL OFFER" It should indicate the commercial terms e.g. price, terms of payment, mode of payment, mode of supply.

Each part should be placed in a separate sealed cover. The envelope should be inscribed with Part-I "Technical Quotation without Price" and Part-II "Commercial Quotation with Price".

- 2.2 The Tendering procedure as laid down in PPRA Rule No. 36(b) i.e. Single Stage two envelopes will be applicable.
- 2.3 The quotation must remain valid for, at least 120 days from the date of opening of tenders (Commercial Offers).
- 2.4 The quotation should hold good for any reduced or enhanced quantities without notice.
- 2.5 In the event of non-acceptance of offer, intimation may be given to the Tenders on their request.
- 2.6 Conditional offers or alternative offers are likely to be ignored.
- 2.7 Quotations should be based on FOB. The consignment will be shipped through Pakistan National Shipping Corporation (PNSC). In case there is no PNSC service in the country of shipping, please quote on C & F basis. The freight should be indicated separately. Insurance premium should not be included in the quoted price. However, where insurance is considered necessary, advice to that effect should be given in the quotation.
- 2.8 Submission of the offer through an agent in Pakistan should be avoided. In case it is considered inevitable, the agent's quotation must invariably be accompanied by the original proforma invoice from the principals/ manufacturers. **However, contract will be placed on principals / manufacturers.**
- 2.9 Country of origin and port of shipment to be stated.
- 2.10 The offer of principal must clearly indicate whether the rate quoted is inclusive of agent's commission, and if inclusive rate of commission included be specified.
- 2.11 Supplier will render necessary information regarding hazardous effects on environment, of the materials/products supplied by them, in their quotations and shipping/dispatch documents.
- 2.12 The Supplier will furnish a declaration regarding fees, commission and brokerage / environmental effect etc payable by the firm along with shipping documents.
- 2.13 If the requisite information is not furnished on the TE form or offer received is not in conformity with the requirement of the TE, the offer shall be ignored.

Contd...

3. **INSPECTION**

- 3.1 Pre-shipment inspection / acceptance of machine at OEM's premises will be conducted by 02 x POF Official for 01 x week starting alongwith training team. The inspection team besides others will particularly carry out trial run of the machine and it will be considered acceptable subject to production of 100 x components each to Drg # SK/COM-8073, SK/COM-8074, SK/COM-8075, SK/COM-8076 on the machine.
- 3.2 The machine after installation and commissioning shall be accepted on firm's warranty / guarantee. The warranty / guarantee shall be binding on the supplier for a period of 12 x months reckoning from the date of FAT of the machine.

4. **ACCEPTANCE OF OFFERS**

- 4.1 The procuring agency may reject all bids or proposals at any time prior to the acceptance of a bid or proposal. The procuring agency shall upon request communicate to any supplier or contractor who submitted a bid or proposal, the grounds for its rejection of all bids or proposals, but is not required to justify those grounds.
- 4.2 Procuring agency shall incur no liability, solely by virtue of its invoking sub-rule (1.1) towards suppliers or contractors who have submitted bids or proposals.
- 4.3 Notice of the rejection of all bids or proposals shall be given promptly to all suppliers or contractors that submitted bids or proposals.

5. **BID SECURITY**

- 5.1 A copy of bid security should accompany the tender in shape of deposit at call receipt / Pay order / Banker Cheque from schedule bank drawn in favour of **GM-Maint & SVS-AA (POF Wah Cantt)**.
- 5.2 Bid Security Instrument in original must accompany with the commercial offer as under:-
 - i. Registered / indexed firms including foreign firms – 2% of quoted value subject to max ceiling of Rs. 0.50 Mn.
 - ii. Registered / un-indexed firms including foreign firms – 3% of quoted value subject to max ceiling of Rs. 0.75 Mn.
 - iii. Un-registered firms including foreign firms – 5% of quoted value subject to max ceiling of Rs. 1.00 Mn.
 - iv. Government organization / production units / state owned enterprises / welfare projects of Svcs HQ – Rs. 50 Mn. can be waived off on request by DG(C).
 - v. Bid money will be returned to un successful (less first three lowest quote firms) bidders on opening of commercial offers.
 - vi. Bid money will be returned to successful bidder on submission of performance bond / unconditional BG.
 - vii. Quotation accompanied with less bid money will be accepted on provisional basis for 10 x days after opening of bids. However, the firms are bound to provide / furnish the balance bid money within 10 x days after opening of bid otherwise such quotations will be ignored or rejected.
 - viii. Offers received without bid security will not be entertained.
 - ix. Bid money will be forfeited in case the quotation is withdrawn before the expiry of its validity date.

Contd...

6. **PERFORMANCE BOND**

- (a) The successful bidder will provide Performance Bond at the rate of 10% of FOB value of the contract in favour of Controller of Military Accounts (CMA), Wah Cantt. The Performance Bond will be furnished in the form of Deposit at Call Receipt (CDR) from any scheduled Bank in Pakistan or an unconditional bank guarantee on prescribed Proforma covered by any schedule bank in Pakistan. The Performance Bond shall be furnished within 45 days from the date of opening of Letter of Credit. It shall be valid for a period of 24 months from the date of opening of letter of credit. The same will be got extended upto 12 x months after successful installation, commissioning & FAT of the machine accordingly. If the Performance Bond is not furnished within the above mentioned prescribed time, the Purchaser reserves the right to cancel the contract and make other arrangements for purchase of the machine at the risk and expense of the Supplier.
- (b) No Performance Bond will be required if the total FOB value of the contract is less than US \$ 50,000 and contract is placed directly on the foreign supplier.

7. **FAILURE TO SUPPLY THE STORES**

All deliveries must be completed by the specified date. If the failure to deliver the stores within the scheduled time should have a risen from "Force Majeure", which the Purchaser may admit as reasonable ground for further time, he will allow such additional time as he may consider to have been required by the circumstances of the case. Otherwise, he will be entitled, at his discretion, to cancel the contract; and/or, claim liquidated damages upto 2% but not less than 1% of the contract price of the items and their quantities for each and every month or part of a month, beyond the specified delivery date, during which these may not be delivered, subject to a maximum of 10% of the total contract value of particular store which remained unsupplied either in part or in full or, to purchase, from elsewhere, the unsupplied stores at the risk and cost of the Supplier.

8. **PAYMENT**

Payment to the supplier will be made through irrevocable letter of credit with the following terms and conditions:-

- i. 70% payment will be released through LC against shipping documents including Acceptance Certificate signed by PSI team, confirming satisfactory pre-shipment inspection.
- ii. 30% payment will be paid through LC upon final acceptance subject to the following certifications signed by Inspection Team and MD-AA:-
 - a. Receipt of the machines in POF Wah Cantt along with all spares, tooling accessories, lubricant, software, manual standard / catalogue.
 - b. Successful installation & commissioning of machine at POF premises.
 - c. Successful Final Acceptance Test (F.A.T) requiring the specific Qty of Successful production/processing of the components as per requirement.

All Bank charges incurred in Pakistan in connection with the establishment of LC will be borne by the Purchaser, whereas all Bank charges incurred in connection with drawing of payment including charges for confirmation of LC by the advising Bank/Foreign Bank will be borne by the Supplier.

Contd...

9. **ARBITRATION**

All matters of dispute or difference, except regarding rejection of stores by the inspector and / or cancellation of contract by the purchaser arising out of this agreement between the parties hereto, the settlement of which is not otherwise specially provided for in this agreement, shall be referred for adjudication to two arbitrators, one to be named by each party, who before entering upon the reference shall appoint an umpire by mutual agreements, and if they do not agree a judge of superior court shall appoint the umpire, the arbitration proceeding shall be held in Pakistan under the Pakistani law. The arbitration awards shall be un-spoken.

10. **SECURITY OF INFORMATION**

The tenderer and his employees must not communicate any information relating to the sale/purchase of stores under this enquiry to any person other than the manufacturer or to any press or agent not authorized in writing by POFs to receive it.

Please return the Schedule to the Tender duly signed by the specified date, along with the specifications drawings etc. if any, enclosed herewith - even if you are unable to quote.

WARNING

In case the firm abstain from making offers or fail to return/acknowledge the tender form by the specified date on three consecutive occasions, no further tender enquiry may be issued to them and their names would liable to be removed from the approved list.

NOTE:

Offers / bids through **Email & Fax** are not acceptable. The offers / bids must be submitted with warranty / guarantee certificate on firm's original letter head pad through **Mail / Courier**.

Yours faithfully,



**(Munir Ahmad Naper)
Managing Director-AA**

For and on behalf of the President
of Islamic Republic of Pakistan

Tele: 0092-51-905521035, 0092-51-905521301

Fax: 0092-51-9271400

PAKISTAN ORDNANCE FACTORIESSCHEDULE TO TENDER NO. 3521-2-44-54-FP-Capt-Pur-AA, dated 22-02-2025**(1) FOR PLANT AND MACHINERY**

(1)	(2)	(3)	(4)	(5)		(6)
Item No.	Description with Specs etc.	Unit	Qty.	Price Per Unit (FOB Value)		Delivery Date
				In Figures	In Words	
1	Variable Pressure Oil Hydraulic Band Pressing Machine	No.	01			

- (2) Specifications: Enclosed as Annexure-'A'
(3) Components Drawings: Enclosed as Annexure-'B'
(4) Special Conditions: Enclosed as Annexure-'C'
(5) Tech. Comparison: Enclosed as Annexure-'D'
(6) Bid Qualification & Selection Criteria: Enclosed as Annexure-'E'
(7) Performa for Supplier/Firm: Enclosed as Annexure-'F'

Note:- **SINGLE STAGE-TWO ENVELOPE PROCEDURE:**

- i. The bid shall comprise a single package containing two envelopes. Each envelope shall contain separately the technical and financial proposal.
- ii. The envelope shall be marked as "Technical Proposal" & "Financial Proposal" in bold and legible letters to avoid confusion.
- iii. Initially, only the envelope marked "Technical Proposal" shall be opened.
- iv. The envelope marked as "Financial Proposal" shall be retained in the custody of Bid Centre.
- v. During the technical evaluation, no amendments in the technical proposal shall be permitted.
- vi. The financial proposals of bids shall be opened publicly at a time, date and venue announced and communicated to the bidders in advance.

(8) UNDERTAKING:

Should our offer be accepted, we hereby undertake to supply the stores/render the services contracted on the basis of Conditions of Contract embodied in Form POF 1282, and to deposit the performance bond within the prescribed time, failing which it will constitute a breach of contract, and POF will have the right to purchase the stores/services elsewhere at our risk and cost.

Place _____
Date _____

Signature of Tenderer _____
Name _____
Position _____
Address _____
Income Tax G.I.R No. _____

SPECIFICATION**a. Nomenclature****Variable Pressure Oil Hydraulic Band Pressing Machine****Qty 01 No****b. Technical Parameters**

i.	Operating Pressure	0 ~ 400 bar
ii.	Pressing force	100-800 kN (Adjustable)
iii.	Drive Band Material	Iron, Copper & Gilding Metal
iv.	Radial stroke	5 mm
v.	Production rate	04 Nos / min
vi.	No of plungers	04 Nos
vii.	Electric Motor	As per OEM's Rating
viii.	Operation	Hydraulically Operated
ix.	Control	Electric / Electronic

c. Machine Features

The machine should be equipped with :-

- i. Standard Safety Devices
- ii. Adjustable Speed, Pressure & Flow
- iii. Variable Displacement Pump
- iv. High-Torque, Low-Speed Motor
- v. Double-Acting, Heavy-Duty Cylinders
- vi. Manual Feeding System
- vii. Interchangeable Crimping Jaws for different Band Profiles and Sizes as per Drg # SK/COM-8073, SK/COM-8074, SK/COM-8075, SK/COM-8076
- viii. Water Based Hydraulic Oil Cooler & Heat Exchanger
- ix. Electric Control Panels with Cooling / Exhaust System
- x. Two Hand Start / Stop Push Buttons & Power Control Knobs
- xi. Pressure / Temperature Gauges

d. Accessories

03 × Set of Crimping Jaws each to Drg # SK/COM-8073, SK/COM-8074, SK/COM-8075, SK/COM-8076

e. Tooling

- i. The machine to be tooled up for pressing of following components:-
 - a. 20mm Cylindrical SK/COM-8073
 - b. 23mm Cylindrical SK/COM-8074
 - c. 35mm Cylindrical SK/COM-8075
 - d. 40mm Cylindrical SK/COM-8076
- ii. 01 × Tool Kit for running & planned maintenance of Machine

f. Spares

Electrical, Electronic & Mechanical spare parts for 5,000 operating hours of machine

g. Documentation

04 x sets of following documents in English are required:-

- i. Electric Sequence Control Circuit Diagram of machine
- ii. Technical details of motors and their control
- iii. Operating, maintenance and service manual
- iv. Drawing of cutting tool and equipment
- v. Machine layout diagram will be provided by the firm well before shipment of machine.
- vi. Hydraulic & Pneumatic Control Drawings

h. Site Condition & Available Services

- i. The available electric system on site for functioning of the machine is:
 - 400 ± 5% VAC, 50Hz, 3 Phase, 4-Wire System
 - 230 ± 5% VAC, 50Hz, 1 Phase
- ii. The available compressed air supply on site for functioning of the machine is 6 bar.
- iii. The available climatic conditions for functioning of the machine are :
 - a. Temperature:
 - Winter = 0 to 25 °C
 - Summer = 25 to 50 °C
 - b. Relative Humidity = 15 to 90%

i. Safety

Safety devices in accordance to international standards must include the followings:-

- i. Over Current Tripping System
- ii. Safety guards for rotary parts must be provided
- iii. Mechanical Overload Protection
- iv. Electronic Overload Protection
- v. The electric equipment should be earthed less than 01 ohm.
- vi. Equipment should have line protection circuit breakers with thermally delayed overload relays and or electro-magnetic quick-acting relays, as required.
- vii. It should be followed by cut-out and safety fuses, if necessary.
- viii. All motors should be appropriately protected as per IP standard.
- ix. The industrial electrical measuring instruments, wherever used should have an accuracy of Class-I or better.

j. Training

- i. Free of cost training for 01 × week for 03 × POF Officials on programming, operation and maintenance at OEM’s premises.
- ii. Air tickets, Boarding / Lodging and DA expenses in respect of Training teams would be borne by purchaser.

k. Pre-shipment Inspection

- i. Pre-shipment inspection / acceptance of machine at OEM’s premises will be conducted by 02 × POF Officials for 01 × week starting alongwith training team. The inspection team besides others will particularly carry out trial run of the machine and it will be considered acceptable subject to production of 100 × components each to Drg # SK/COM-8073, SK/COM-8074, SK/COM-8075, SK/COM-8076 on the machine.
- ii. Inspection of produced components will be carried out through gauges, SMEs and through enlargement where required. Provisioning of applicable gauges will be made by purchaser whereas arrangements for SMEs and enlargement will be made by OEM.
- iii. Despatch of semi finished component / material, gauges for trial run of the machine at OEM’s premises will be responsibility of the firm through firm’s Local Rep.
- iv. Specified material will be used for production of components during PSI. The provisioning of material will be made by the OEM.
- v. Air tickets, Boarding / Lodging and DA expenses in respect of PSI teams would be borne by Purchaser.

l. Installation & Commissioning

- i. Installation & commissioning of the machine is the responsibility of OEM.
- ii. POF will provide services and manpower to help during installation & commissioning.
- iii. All safety risks associated with installation & commissioning are the responsibility of OEM.
- iv. Needed material (Mechanical / Electrical) for installation & commissioning would be managed by the OEM.
- v. Machine layout diagram will be provided by the firm well before shipment of machine.
- vi. The supplier will provide information regarding time schedule and total man-weeks of its engineers / technicians required for installation, commissioning and trial production run of the machine. All expenses, including boarding & lodging, air travel and daily allowances of the engineers / technicians are to be borne by the supplier. However Local transportation shall be arranged by the purchaser.
- vii. During the warranty / guarantee period, any replacement of faulty machine part will be responsibility of the supplier. The supplier will provide machine part free of cost and without any obligation to the purchaser.
- viii. The machine after installation and commissioning shall be accepted on firm’s warranty / guarantee. The warranty / guarantee shall be binding on the supplier for a period of 12 × months reckoning from the date of FAT of the machine.

m. Final Acceptance Test

- i. Final acceptance test will be performed at purchaser premises.
- ii. The machine will be run for trial to check abnormal noise, vibration, heat up, leakages etc.
- iii. 500 × bands will be pressed each to Drg # SK/COM-8073, SK/COM-8074, SK/COM-8075 & SK/COM-8076 on the machine. Material will be provided by Purchaser.
- iv. Based on successful inspection report, a certificate will be issued by purchaser in respect of successful installation and commissioning of the machine.
- v. The OEM will provide free of cost on job training on the machine to Engineers / Technicians at purchaser premises.

n. Delivery Schedule

- i. Delivery of the machine will be made within 06 x months from establishment of Letter of Credit.
- ii. Delivery of the machine will be made on C&F basis.

o. Country of Origin

Europe, UK, USA, Japan, South Korea & any other country manufacturing under the license of OEM

p. Colour

Green RAL-6011

DIMENSIONS IN MM
THIRD ANGLE PROJECTION

BODY

MATERIAL:- STEEL BS 970 Pt-1 GRADE 070M20

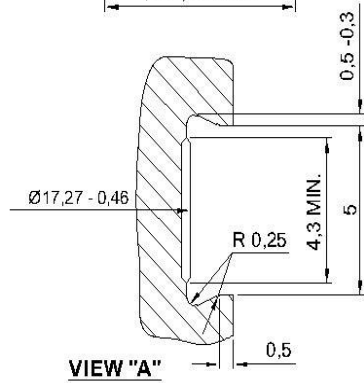
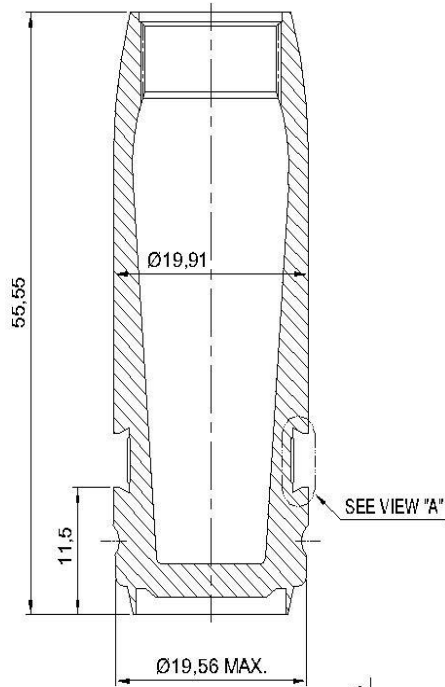

VIEW "A"

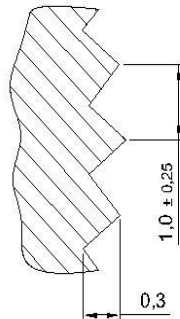

DETAIL OF KNURLS

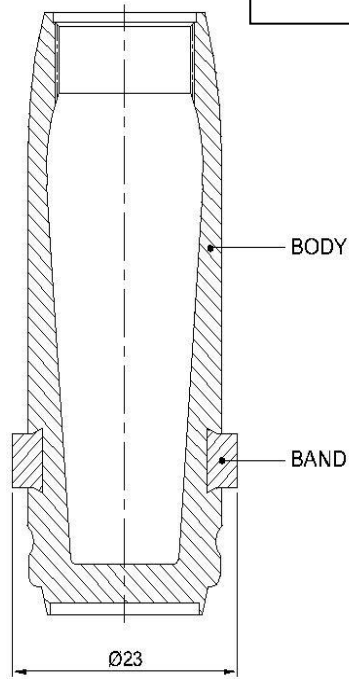

ASSEMBLY

BAND

MATERIAL:- COPPER TO SPEC. DEF-STAN 13/95 ISSUE-1
HARDNESS:- 80 - 103 HV 5Kg

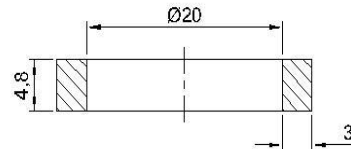

FOR BAND PRESSING

SHEET 1 OF 1

DRAWN:	ANSAR IQBAL (C/MAN)
CHECKED:	SAJJAD HUSSAIN T.O
APP'VD:	M. ANWAR A.M
BASED ON.	
DRG.No.	SK / COM-8073
DATE:	13-11-2024

DIMENSIONS IN MM
THIRD ANGLE PROJECTION.

MATERIAL:-

S 20 A - YB 683 - 70

BODY

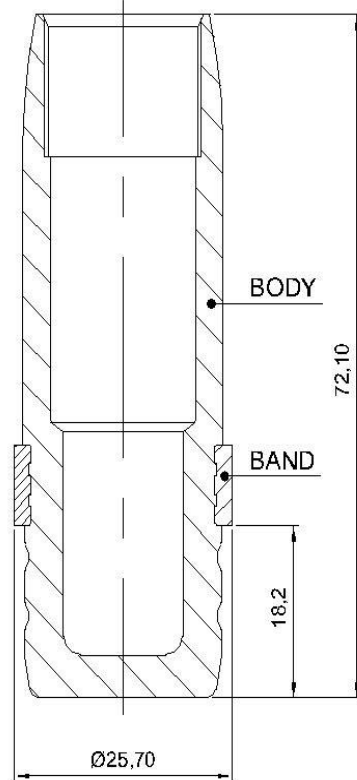
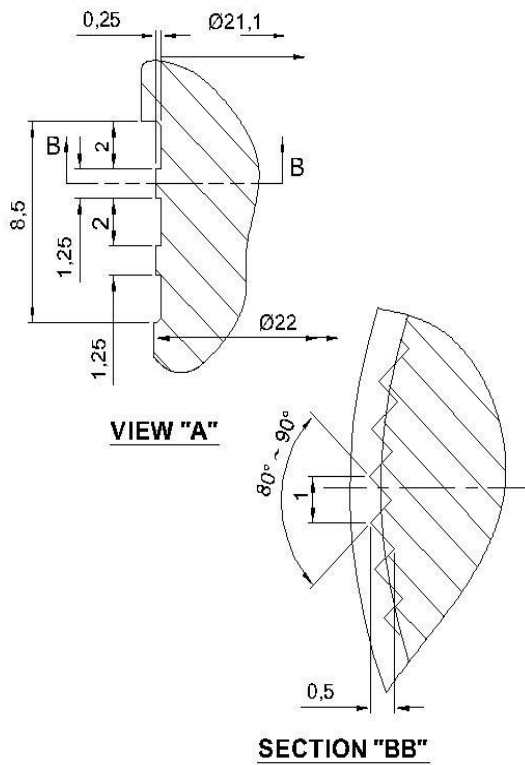
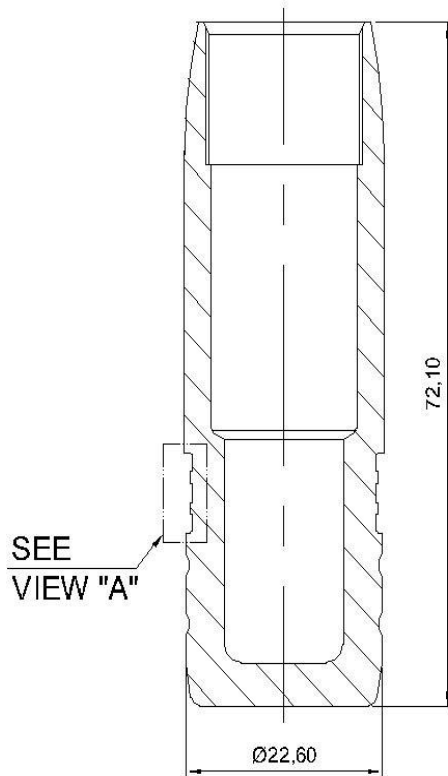

ASSEMBLY

BAND

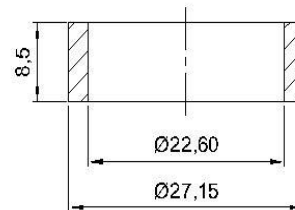

MATERIAL:-

DRAWN COPPER TUBE
TO SPEC. DEF-STAN 13-95/1 TYPE - I

SHEET:- 1 OF 1

DRAWN: SAGHR (A.T.O)

CHECKED: SAJJAD HUSSAIN (T.O)

APP'VD: M. ANWAR (A.M)

DRG.No.

SK/COM-8074

FOR BAND PRESSING

DATE: 14 - 11 - 2024

DIMENSIONS IN MM
THIRD ANGLE PROJECTION

BODY:-

MATERIAL

CARBON STEEL TO SPEC. YB 479-87 "OR" STEEL BAR COLD
DRAWN TO SPEC. DEF STAN 13-47/ ISSUE-5, SS/E-24

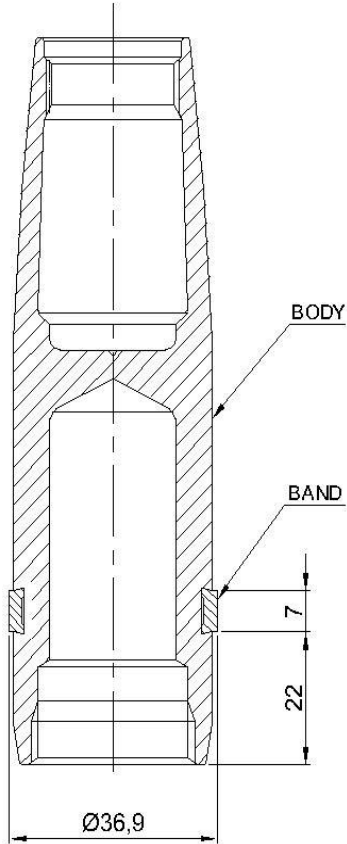

BAND

MATERIAL

SEAMLESS STEEL TUBE TO SPEC. VC 8 AL,
MAT. No. WS 1.9390-7, COND. 'K' (COLD DRAWN)

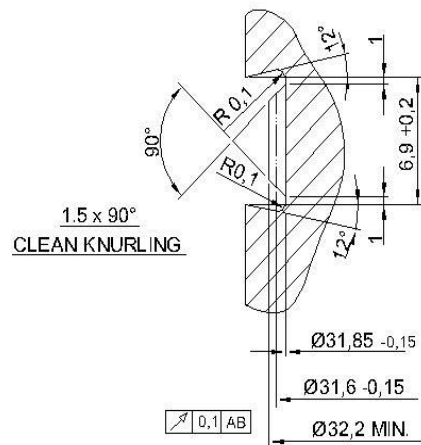
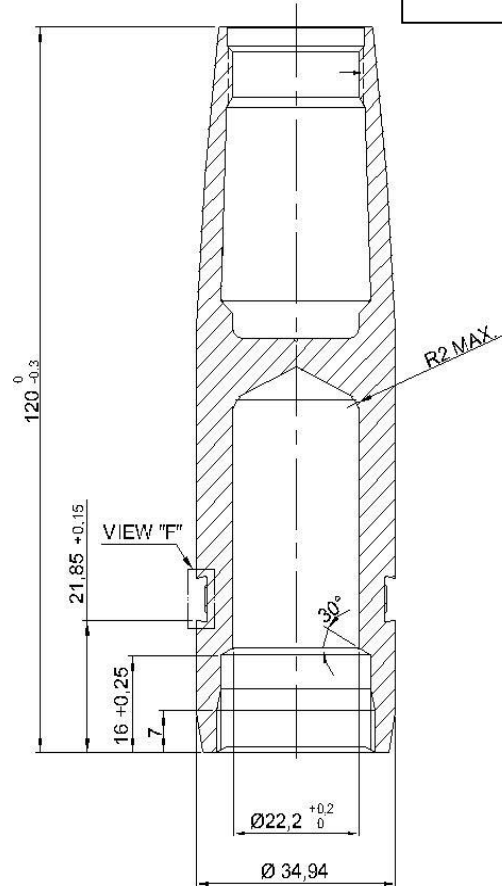
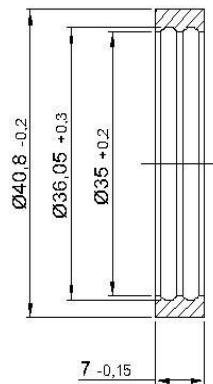

ENLARGED
VIEW "F"

FOR BAND PRESSING

DRAWN:	M.WAQAS
CHECKED:	SAJJAD HUSSAIN (T.O)
APP'VD:	M. ANWAR (A.M)
DRG.No.	SK / COM-8075
DATE:	14-11-2024

DIMENSIONS IN MM
THIRD ANGLE PROJECTION

ASSEMBLY

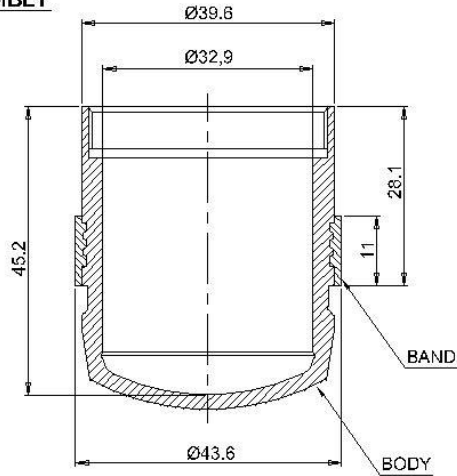

BAND

MATERIAL:-

COPPER TUBE TO SPEC. DEF-STAN 13-95/1 TYPE-I,
ANNEALED

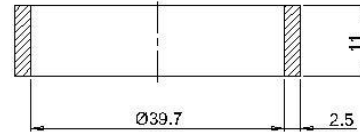

BODY

MATERIAL:-

DEF-STAN 13-47/3, SS/A21

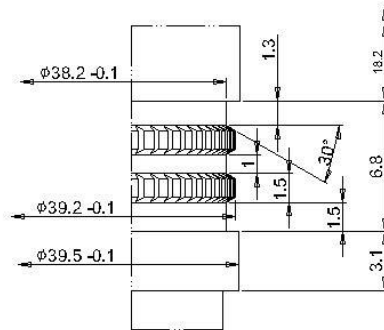
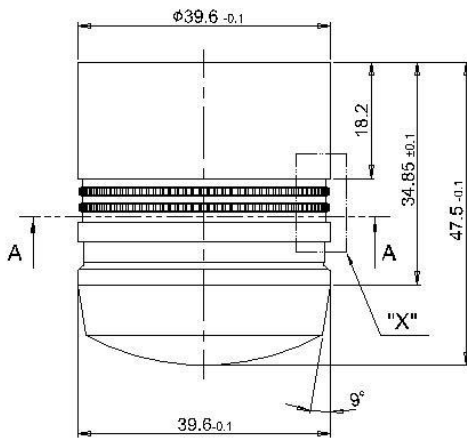

ENLARGED VIEW "X"

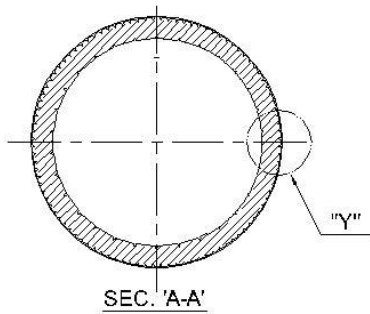

SEC. 'A-A'

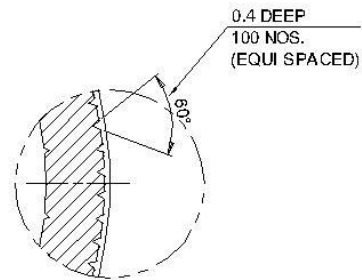

ENLARGED VIEW "Y"

SHEET 1 OF 1

DRAWN: M.WAQAS A.T.O

CHECKED: SAJJAD HUSSAIN T.O

APP'VD: M. ANWAR A.M

BASED ON.

DRG.No.

SK / COM-8076

DATE: 13-11-2024

FOR BAND PRESSING

SPECIAL CONDITIONS**a) TO BE FULFILLED AT THE TIME OF BIDDING / REPLY OF TENDER ENQUIRY**

- i. It may be confirmed that you will be able to obtain export license from your Govt. in the event of successful bidding.
- ii. OEM/authorized suppliers with company profile/brochure.
- iii. Performance of such type of machine supplied to various customer.
- iv. Item wise price of machine, equipment & accessories alongwith Electrical, Electronic for control and Mechanical Spare Parts for 02 x years running maintenance should be quoted as part of commercial offer (Part-II). Essential maintenance & operational spares shall be supplied and ensure backup support for provisioning of spares for 15 years.
- v. Reference Column 2.2 of Tender Enquiry Form No. 1262, any indication whatsoever of the price in Part-I of the quotation will render it invalid and void.
- vi. The supplier must fill in the Proforma of Technical Comparison enclosed as Annexure-‘D’ to the specifications and submit along with the technical offer for our instant evaluation.
- vii. The supplier will provide necessary brochures and technical literature alongwith Part-I of the offer (Technical Offer).
- viii. POF shall deal directly with the manufacturer / supplier of the machine. In case of manufacturer / supplier chooses to have a local agent, payment of agent’s commission etc., shall be supplier’s responsibility and shall not be included in the price quoted in Part-II of the offer (Commercial Quotation). However, contract will be placed on principals / manufacturers.

b) CONDITIONS TO BE PART OF FORMAL CONTRACT AND MAY BE KEPT IN VIEW BEFORE BIDDING

- i. Payment to the supplier will be made through irrecoverable letter of credit with the following terms and conditions:-
 - a. 70% payment will be released through LC against shipping documents including Acceptance Certificate signed by PSI team, confirming satisfactory pre-shipment inspection.
 - b. 30% payment will be paid through LC upon final acceptance subject to the following certifications signed by Inspection Team and MD-AA:-
 - i. Receipt of the machines in POF Wah Cantt along with all spares, tooling accessories, lubricant, software, manual standard / catalogue.
 - ii. Successful installation & commissioning of machine at POF premises.
 - iii. Successful Final Acceptance Test (F.A.T) requiring the specific Qty of Successful production/processing of the components as per requirement.
- ii. The manufacturer / supplier will train at his premises 03 x POF officials for 01 x Week on programming, operation and maintenance machine free of cost.
- iii. Pre-shipment inspection / acceptance of machine at OEM’s premises will be conducted by 02 x POF Official for 01 x week starting along with training. The inspection team besides others will particularly carry out trial run of the machine and it will be considered acceptable subject to production of 100 x components each to Drg # SK/COM-8073, SK/COM-8074, SK/COM-8075, SK/COM-8076 on the machine.
- iv. Inspection of produced components will be carried out through gauges, SMEs and through enlargement where required. Provisioning of applicable gauges will be made by purchaser whereas arrangements for SMEs and enlargement will be made by OEM.

- v. Air tickets for both sides, boarding & lodging, inland transportation and provisioning of payment of Daily Allowance in respect of training & PSI teams will be borne by POF.
- vi. The manufacturer / supplier will ensure supply of foundation drawings and installation manual to the consignee at least two months before shipment of the machine.
- vii. The machine will be installed and commissioned at POF by the supplier engineers and 500 x component bands to Drg # SK/COM-8073, SK/COM-8074, SK/COM-8075, SK/COM-8076, on the machine. Inspection of produced components will be carried out through gauges, SMEs and through enlargement where required Provisioning of applicable gauges will be made by purchaser.
- viii. The manufacturer/supplier will undertake regarding backup support for provisioning of Mechanical, Electrical & Electronic Spare Parts for 15 years maintenance after commissioning of the machine as and when required by POF. The undertaking shall be furnished by the firm in the shape of a certificate to be issued on the letter head of the firm alongwith the accepted copies of the contract (to be returned to the buyer).
- ix. Four sets of documents in English language Electric Sequence Control Circuit Diagram of machine, Technical details of motors and their control, Operating, maintenance and service manual, Drawing of cutting tool and equipment. Machine layout diagram will be provided by the firm well before shipment of machine and Hydraulic & pneumatic controls drawings.
- x. The manufacturer/supplier will provide performance bond in the shape of Bank Guarantee @ 10% of net FOB (LC) value which will be valid for 24 x months from the date of opening of letter of credit. The same will be got extended upto 12 x months after successful FAT of the machine.
- xi. The spare parts will be properly tagged with Part No. / Serial No. for identification.
- xii. The machine must be packed in seaworthy packing and protected adequately & appropriately to the mode of dispatch against damages from water or other substances during sea voyage and over land journey to withstand the rough handling involved in transit and provide proper preservation of the machine while held in storage by the consignee.
- xiii. The machine must include complete tool kit for running & planned maintenance of the machine.
- xiv. POF will hold no responsibility for any damage occurred during shipment of the machine.
- xv. The supplier will provide on letter head duly signed and stamped declaration of fees, commissions & brokerage etc. along with the accepted copies of the contract.

Signature of the Supplier:

Name _____

Status in the Firm _____

Address _____

Place _____

Date _____

**TECHNICAL COMPARISON
(TO BE FILLED BY SUPPLIER)**

Sr. #	TENDER SPECIFICATIONS	OFFERED SPECIFICATIONS WITH REFERENCE TO PAGE NO. OF QUOTATION

BID QUALIFICATION & SELECTION CRITERIA

Sr #	Technical/Commercial aspects to be considered to ease out most advantageous bid	Compliance Level			Remarks
		Fully Complied	Partially Complied	Not Complied	
1*	Bid submitted in compliance with PPRA Rule 36(d)				
2*	Confirm to Tender Specification				
3*	Confirm Tender Quantity (s)				
4	Complete Technical literature/Brochure/catalogue provided in first go along with technical				
5.	Prices are valid for any reduced quantity(s) without notice				
6*	120 days bid validity from date of opening of commercial offers/bid confirmed				
7	Delivery period as per schedule of tender enquiry				
8	Payment terms as per tender enquiry				
9	In case of new entrant, proof of past performance/ list of identical supplies to prove capabilities in the relevant filed				
10*	Certificate regarding fulfillment of all tender				
11*	T.E undertaking-Signed/Stamped				
12*	Offer/Bid (Tech+Comm) is un conditional				
13*	Complete company profile				
14	Certificate that firm is not blacklisted or under debarment by any Govt/Semi Govt Organization				
15.	Confirmation of performance Bond against LC as per T.E Clause-6				
16*	Main Features as per Annex “A” of T.E				
17*	Technical Requirements as per Annex “A” of T.E				
18*	Site & Operating Conditions as per Annex “A” of T.E				
19*	Country of Origin as per Annex “A” of T.E				
20*	Specification for Electric Supply System as per as per				
21*	Literature Required as per Annex “A” of T.E				
22*	Additional Equipment as per Annex “A” of T.E				
23*	Terms & Conditions as per Annex “A” of T.E				
24*	Comply the proforma as per Annex “F” of T.E				
Note:- Clause with (*) are necessary to be complied. In case of non-compliance of the same, the bid may be disqualified					

Signature of the Tenderer with Stamp
Place _____
Date _____

VARIABLE PRESSURE OIL HYDRAULIC BAND PRESSING MACHINE QTY 01 NO

Firm/Supplier _____

Store Description		Compliance / Non-Compliance by the OEM	Remarks
a. <u>Technical Parameters</u>			
i.	Operating Pressure	0 ~ 400 bar	
ii.	Pressing force	100-800 kN (Adjustable)	
iii.	Drive Band Material	Iron, Copper & Gilding Metal	
iv.	Radial stroke	5 mm	
v.	Production rate	04 Nos / min	
vi.	No of plungers	04 Nos	
vii.	Electric Motor	As per OEM’s Rating	
viii.	Operation	Hydraulically Operated	
ix.	Control	Electric / Electronic	
b. <u>Machine Features</u>			
The machine should be equipped with :-			
i.	Standard Safety Devices		
ii.	Adjustable Speed, Pressure & Flow		
iii.	Variable Displacement Pump		
iv.	High-Torque, Low-Speed Motor		
v.	Double-Acting, Heavy-Duty Cylinders		
vi.	Manual Feeding System		
vii.	Interchangeable Crimping Jaws for different Band Profiles and Sizes as per Drg # SK/COM-8073, SK/COM-8074, SK/COM-8075, SK/COM-8076		
viii.	Water Based Hydraulic Oil Cooler & Heat Exchanger		
ix.	Electric Control Panels with Cooling / Exhaust System		
x.	Two Hand Start / Stop Push Buttons & Power Control Knobs		
xi.	Pressure / Temperature Gauges		
c. <u>Accessories</u>			
03 x Set of Crimping Jaws each to Drg # SK/COM-8073, SK/COM-8074, SK/COM-8075, SK/COM-8076			
d. <u>Tooling</u>			
i. The machine to be tooled up for pressing of following components:-			
a.	20mm Cylindrical SK/COM-8073		
b.	23mm Cylindrical SK/COM-8074		
c.	35mm Cylindrical SK/COM-8075		
d.	40mm Cylindrical SK/COM-8076		
ii.	01 x Tool Kit for running & planned maintenance of Machine		
e. <u>Spares</u>			
Electrical, Electronic & Mechanical spare parts for 5,000 operating hours of machine			

f. <u>Documentation</u>		
04 x sets of following documents in English are required:-		
i. Electric Sequence Control Circuit Diagram of machine		
ii. Technical details of motors and their control		
iii. Operating, maintenance and service manual		
iv. Drawing of cutting tool and equipment		
v. Machine layout diagram will be provided by the firm well before shipment of machine.		
vi. Hydraulic & Pneumatic Control Drawings		
g. <u>Site Condition & Available Services</u>		
i. The available electric system on site for functioning of the machine is:		
• 400 ± 5% VAC, 50Hz, 3 Phase, 4-Wire System		
• 230 ± 5% VAC, 50Hz, 1 Phase		
ii. The available compressed air supply on site for functioning of the machine is 6 bar.		
iii. The available climatic conditions for functioning of the machine are :		
a. Temperature:		
▪ Winter = 0 to 25 °C		
▪ Summer = 25 to 50 °C		
b. Relative Humidity = 15 to 90%		
h. <u>Safety</u>		
Safety devices in accordance to international standards must include the followings:-		
i. Over Current Tripping System		
ii. Safety guards for rotary parts must be provided		
iii. Mechanical Overload Protection		
iv. Electronic Overload Protection		
v. The electric equipment should be earthed less than 01 ohm.		
vi. Equipment should have line protection circuit breakers with thermally delayed overload relays and or electro-magnetic quick-acting relays, as required.		
a) It should be followed by cut-out and safety fuses, if necessary.		
b) All motors should be appropriately protected as per IP standard.		
c) The industrial electrical measuring instruments, wherever used should have an accuracy of Class-I or better.		
i. <u>Training</u>		
i. Free of cost training for 01 x week for 03 x POF Officials on programming, operation and maintenance at OEM's premises.		
ii. Air tickets, Boarding / Lodging and DA expenses in respect of Training teams would be borne by purchaser.		

j. Pre-shipment Inspection		
i. Pre-shipment inspection / acceptance of machine at OEM's premises will be conducted by 02 x POF Officials for 01 x week starting alongwith training team. The inspection team besides others will particularly carry out trial run of the machine and it will be considered acceptable subject to production of 100 x components each to Drg # SK/COM-8073, SK/COM-8074,SK/COM-8075,SK/COM-8076 on the machine.		
ii. Inspection of produced components will be carried out through gauges, SMEs and through enlargement where required. Provisioning of applicable gauges will be made by purchaser whereas arrangements for SMEs and enlargement will be made by OEM.		
iii. Despatch of semi finished component / material, gauges for trial run of the machine at OEM's premises will be responsibility of the firm through firm's Local Rep.		
iv. Specified material will be used for production of components during PSI.The provisioning of material will be made by the OEM.		
v. Air tickets, Boarding / Lodging and DA expenses in respect of PSI teams would be borne by Purchaser.		
k. Installation & Commissioning		
i. Installation & commissioning of the machine is the responsibility of OEM.		
ii. POF will provide services and manpower to help during installation & commissioning.		
iii. All safety risks associated with installation & commissioning are the responsibility of OEM.		
iv. Needed material (Mechanical / Electrical) for installation & commissioning would be managed by the OEM.		
v. Machine layout diagram will be provided by the firm well before shipment of machine.		
vi. The supplier will provide information regarding time schedule and total man-weeks of its engineers / technicians required for installation, commissioning and trial production run of the machine. All expenses, including boarding & lodging, air travel and daily allowances of the engineers / technicians are to be borne by the supplier. However Local transportation shall be arranged by the purchaser.		
vii. During the warranty / guarantee period, any replacement of faulty machine part will be responsibility of the supplier. The supplier will provide machine part free of cost and without any obligation to the purchaser.		
viii. The machine after installation and commissioning shall be accepted on firm's warranty / guarantee. The warranty / guarantee shall be binding on the supplier for a period of 12 x months reckoning from the date of FAT of the machine.		

I. Final Acceptance Test		
i. Final acceptance test will be performed at purchaser premises.		
ii. The machine will be run for trial to check abnormal noise, vibration, heat up, leakages etc.		
iii. 500 x bands will be pressed each to Drg # SK/COM-8073, SK/COM-8074, SK/COM-8075 & SK/COM-8076 on the machine. Material will be provided by Purchaser.		
iv. Based on successful inspection report, a certificate will be issued by purchaser in respect of successful installation and commissioning of the machine.		
v. The OEM will provide free of cost on job training on the machine to Engineers / Technicians at purchaser premises.		
m. Performance Bond		
(i). The successful bidder will provide Performance Bond in foreign currency at the rate of 10% of FOB value of the contract in favour of Controller of Military Accounts (CMA), Wah Cantt. The Performance Bond shall be furnished within 45 days from the date of opening of Letter of Credit. It shall be valid for a period of 24 months from the date of opening of letter of credit. The same will be got extended upto 12 x months after successful installation, commissioning & FAT of the machine accordingly. If the Performance Bond is not furnished within the above mentioned prescribed time, the Purchaser reserves the right to cancel the contract and make other arrangements for purchase of the machine at the risk and expense of the Supplier.		
(ii). No Performance Bond will be required if the total FOB value of the contract is less than US \$ 50,000 and contract is placed directly on the foreign supplier.		
n. Payment Terms & Conditions		
Payment to the supplier will be made through irrevocable letter of credit with the following terms and conditions:-		
(i). 70% payment will be released through LC against shipping documents including Acceptance Certificate signed by PSI team, confirming satisfactory pre-shipment inspection.		
(ii). 30% payment will be paid through LC upon final acceptance subject to the following certifications signed by Inspection Team and MD-AA:-		
a. Receipt of the machines in POF Wah Cantt along with all spares, tooling accessories, lubricant, software, manual standard / catalogue.		
b. Successful installation & commissioning of machine at POF premises.		
c. Successful Final Acceptance Test (F.A.T) requiring the specific Qty of Successful production/processing of the components as per requirement.		
Note:		
All Bank charges incurred in Pakistan in connection with the establishment of LC will be borne by the Purchaser, whereas all Bank charges incurred in connection with drawing of payment including charges for confirmation of LC by the advising Bank/Foreign Bank will be borne by the Supplier.		

o. <u>Procedure for Bidding</u>		
Single Stage – Two Envelop as per PPRA Rules 36 (b)		
p. <u>Delivery Schedule</u>		
i. Delivery of the machine will be made within 06 x months from establishment of Letter of Credit.		
ii. Delivery of the machine will be made on C&F basis.		
q. <u>Country of Origin</u>		
Europe, UK, USA, Japan, South Korea & any other country manufacturing under the license of OEM		
r. <u>Colour</u>		
Green RAL-6011		