



GOVERNMENT OF PAKISTAN
PAKISTAN ORDNANCE FACTORIES
TENDER ENQUIRY

To

Dear Sirs,

Reference: - TENDER ENQUIRY NO. 3521-2-36-54-FP-Capt-Pur-AA, dated 20-02-2025.

You are requested to submit sealed quotations for the item noted on the Schedule to the Tender. Please note the following instructions for filling the tender:-

1. **SUBMISSION OF TENDER**

- 1.1 Tenders will be opened at 1100 hours on 08-04-2025 and must reach at Bid Centre adjacent to Rabita Hall at least half an hour earlier than the opening time on same date. You may witness the opening of the tender if you so desired. If a representative is deputed, he should bring a letter of authority from you. The tender received late will not be entertained.
- 1.2 Only one tender should be included in one envelope. The outside of the envelope should be inscribed with: -

Tender Enquiry No: 3521-2-36-54-FP-Capt-Pur-AA, dated 20-02-2025

Tender to be opened on: 08-04-2025

Address as follows:-

**BID Centre Adjacent To Rabita Hall
Managing Director
Artillery Ammunition Factory
Pakistan Ordnance Factories,
Wah Cantt, Pakistan.
Fax : 051-9314100 & 051-9271400
Email : mdaa@pof.gov.pk
gmservices-aa@pof.gov.pk**

- 1.3 If envelope do not indicate reference of TE or received late, the same will be returned un-opened.

Contd...

1.4 **EVALUATION CRITERIA.**

All the technical proposals will be evaluated / scrutinized initially and commercial Proposals of only those bidders will be opened who will be technically prequalified / accepted. Accordingly, Order / Contract will be awarded to most advantageous bidder on the basis of bid qualification criteria (Annex-E).

2. **GENERAL INSTRUCTIONS REGARDING PREPARATION OF QUOTATIONS**

2.1 For Plant & Machinery, you are required to quote in two parts:-

Part-I "TECHNICAL OFFER" It should exclusively give technical details and literatures/brochures of the offered plant, machinery and equipment; validity date; delivery schedule; and signed undertaking given on the schedule to this Tender Enquiry and country of origin should be clearly mentioned. It must not indicate price, costs etc.

Part-II "COMMERCIAL OFFER" It should indicate the commercial terms e.g. price, terms of payment, mode of payment, mode of supply.

Each part should be placed in a separate sealed cover. The envelope should be inscribed with Part-I "Technical Quotation without Price" and Part-II "Commercial Quotation with Price".

2.2 The Tendering procedure as laid down in PPRA Rule No. 36(b) i.e. Single Stage two envelopes will be applicable.

2.3 The quotation must remain valid for, at least 120 days from the date of opening of tenders (Commercial Offers).

2.4 The quotation should hold good for any reduced or enhanced quantities without notice.

2.5 In the event of non-acceptance of offer, intimation may be given to the Tenders on their request.

2.6 Conditional offers or alternative offers are likely to be ignored.

2.7 Quotations should be based on FOB. The consignment will be shipped through Pakistan National Shipping Corporation (PNSC). In case there is no PNSC service in the country of shipping, please quote on C & F basis. The freight should be indicated separately. Insurance premium should not be included in the quoted price. However, where insurance is considered necessary, advice to that effect should be given in the quotation.

2.8 Submission of the offer through an agent in Pakistan should be avoided. In case it is considered inevitable, the agent's quotation must invariably be accompanied by the original proforma invoice from the principals/ manufacturers. **However, contract will be placed on principals / manufacturers.**

2.9 Country of origin and port of shipment to be stated.

2.10 The offer of principal must clearly indicate whether the rate quoted is inclusive of agent's commission, and if inclusive rate of commission included be specified.

2.11 Supplier will render necessary information regarding hazardous effects on environment, of the materials/products supplied by them, in their quotations and shipping/dispatch documents.

2.12 The Supplier will furnish a declaration regarding fees, commission and brokerage / environmental effect etc payable by the firm along with shipping documents.

2.13 If the requisite information is not furnished on the TE form or offer received is not in conformity with the requirement of the TE, the offer shall be ignored.

3. **INSPECTION**

- 3.1 Pre-shipment inspection / acceptance of Plant at OEM's premises will be conducted by 03 x POF Officials for 01 x week starting from 2nd week of training. The inspection team besides others will particularly carry out trial run of the Plant and it will be considered acceptable subject to satisfactory plating of 100 x components each to Drg # SK/COM-8079 on the Plant.
- 3.2 The Plant after installation and commissioning shall be accepted on firm's warranty / guarantee. The warranty / guarantee shall be binding on the supplier for a period of 03 x Years reckoning from the date of FAT of the Plant.

4. **ACCEPTANCE OF OFFERS**

- 4.1 The procuring agency may reject all bids or proposals at any time prior to the acceptance of a bid or proposal. The procuring agency shall upon request communicate to any supplier or contractor who submitted a bid or proposal, the grounds for its rejection of all bids or proposals, but is not required to justify those grounds.
- 4.2 Procuring agency shall incur no liability, solely by virtue of its invoking sub-rule (1.1) towards suppliers or contractors who have submitted bids or proposals.
- 4.3 Notice of the rejection of all bids or proposals shall be given promptly to all suppliers or contractors that submitted bids or proposals.

5. **TENDER FEE (For Local Supplier only)**

The tender must be accompanied by a copy of non-refundable fee by means of a crossed postal order/pay order for Rs. 500/- in favour of: **Director-Admin-POFs, Wah Cantt.** The tender fee instrument in original must be provided on day/date of tender opening in the Bid Center.

6. **BID SECURITY**

- 6.1 A copy of bid security should accompany the tender in shape of deposit at call receipt / Pay order / Banker Cheque from schedule bank drawn in favour of **GM-Maint & SVS-AA (POF Wah Cantt).**
- 6.2 Bid Security Instrument in original must accompany with the commercial offer as under:-
 - i. Registered / indexed firms including foreign firms – 2% of quoted value subject to max ceiling of Rs. 0.50 Mn.
 - ii. Registered / un-indexed firms including foreign firms – 3% of quoted value subject to max ceiling of Rs. 0.75 Mn.
 - iii. Un-registered firms including foreign firms – 5% of quoted value subject to max ceiling of Rs. 1.00 Mn.
 - iv. Government organization / production units / state owned enterprises / welfare projects of Svcs HQ – Rs. 50 Mn. can be waived off on request by DG(C).
 - v. Bid money will be returned to un successful (less first three lowest quote firms) bidders on opening of commercial offers.
 - vi. Bid money will be returned to successful bidder on submission of performance bond / unconditional BG.
 - vii. Quotation accompanied with less bid money will be accepted on provisional basis for 10 x days after opening of bids. However, the firms are bound to provide / furnish the balance bid money within 10 x days after opening of bid otherwise such quotations will be ignored or rejected.
 - viii. Offers received without bid security will not be entertained.
 - ix. Bid money will be forfeited in case the quotation is withdrawn before the expiry of its validity date.

Contd...

7. **PERFORMANCE BOND**

i. **For Foreign Supplier**

- (a). The successful bidder will provide Performance Bond in foreign currency at the rate of 10% of FOB value of the contract in favour of Controller of Military Accounts (CMA), Wah Cantt. The Performance Bond shall be furnished within 45 days from the date of opening of Letter of Credit. It shall be valid for a period of 24 months from the date of opening of letter of credit. The same will be got extended upto 12 x months after successful installation, commissioning & FAT of the machine accordingly. If the Performance Bond is not furnished within the above mentioned prescribed time, the Purchaser reserves the right to cancel the contract and make other arrangements for purchase of the machine at the risk and expense of the Supplier.
- (b). No Performance Bond will be required if the total FOB value of the contract is less than US \$ 50,000 and contract is placed directly on the foreign supplier.

ii. **For Local Supplier**

The Performance Bond will be furnished in local currency in the form of Deposit At Call Receipt (CDR) from any scheduled Bank in Pakistan or an unconditional bank guarantee on prescribed Proforma covered by any schedule bank in Pakistan.

8. **FAILURE TO SUPPLY THE STORES**

All deliveries must be completed by the specified date. If the failure to deliver the stores within the scheduled time should have a risen from "Force Majeure", which the Purchaser may admit as reasonable ground for further time, he will allow such additional time as he may consider to have been required by the circumstances of the case. Otherwise, he will be entitled, at his discretion, to cancel the contract; and/or, claim liquidated damages upto 2% but not less than 1% of the contract price of the items and their quantities for each and every month or part of a month, beyond the specified delivery date, during which these may not be delivered, subject to a maximum of 10% of the total contract value of particular store which remained unsupplied either in part or in full or, to purchase, from elsewhere, the unsupplied stores at the risk and cost of the Supplier.

9. **Payment Terms & Conditions**

i. **For Foreign Supplier (Negotiable)**

Payment to the supplier will be made through irrevocable letter of credit with the following terms and conditions:-

- (a). 70% payment will be released through LC against shipping documents including Acceptance Certificate signed by PSI team, confirming satisfactory pre-shipment inspection.
- (b). 30% payment will be paid through LC upon final acceptance subject to the following certifications signed by Inspection Team and MD-AA:-
 - i. Receipt of the machines in POF Wah Cantt along with all spares, tooling accessories, lubricant, software, manual standard / catalogue.
 - ii. Successful installation & commissioning of plant at POF premises.
 - iii. Successful Final Acceptance Test (F.A.T) requiring the specific Qty of Successful production/processing of the components as per requirement.

Contd...

Note:

All Bank charges incurred in Pakistan in connection with the establishment of LC will be borne by the Purchaser, whereas all Bank charges incurred in connection with drawing of payment including charges for confirmation of LC by the advising Bank/Foreign Bank will be borne by the Supplier.

ii. For Local Supplier

100% payment will be paid through cross cheque issued by CMA POF Wah upon final acceptance subject to the following certifications signed by Inspection Team and MD-AA:-

- (a). Receipt of the machines in POF Wah Cantt along with all spares, tooling accessories, lubricant, software, manual standard / catalogue.
- (b). Successful installation & commissioning of machine at POF premises.
- (c). Successful Final Acceptance Test (F.A.T) requiring the specific Qty of Successful production/processing of the components as per requirement.

10. ARBITRATION

All matters of dispute or difference, except regarding rejection of stores by the inspector and / or cancellation of contract by the purchaser arising out of this agreement between the parties hereto, the settlement of which is not otherwise specially provided for in this agreement, shall be referred for adjudication to two arbitrators, one to be named by each party, who before entering upon the reference shall appoint an umpire by mutual agreements, and if they do not agree a judge of superior court shall appoint the umpire, the arbitration proceeding shall be held in Pakistan under the Pakistani law. The arbitration awards shall be un-spoken.

11. SECURITY OF INFORMATION

The tenderer and his employees must not communicate any information relating to the sale/purchase of stores under this enquiry to any person other than the manufacturer or to any press or agent not authorized in writing by POFs to receive it.

Please return the Schedule to the Tender duly signed by the specified date, along with the specifications drawings etc. if any, enclosed herewith - even if you are unable to quote.

WARNING

In case the firm abstain from making offers or fail to return/acknowledge the tender form by the specified date on three consecutive occasions, no further tender enquiry may be issued to them and their names would liable to be removed from the approved list.

NOTE:

Offers / bids through **Email & Fax** are not acceptable. The offers / bids must be submitted with warranty / guarantee certificate on firm's original letter head pad through **Mail / Courier**.

Yours faithfully,

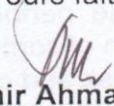
(Munir Ahmad Naper)
Managing Director-AA

For and on behalf of the President
of Islamic Republic of Pakistan

PAKISTAN ORDNANCE FACTORIESSCHEDULE TO TENDER NO. 3521-2-36-54-FP-Capt-Pur-AA, dated 20-02-2025**(1) FOR PLANT AND MACHINERY**

(1)	(2)	(3)	(4)	(5)		(6)
Item No.	Description with Specs etc.	Unit	Qty.	Price Per Unit (FOB Value)		Delivery Date
				In Figures	In Words	
1	Surface Treatment Plant (Passivation)	No.	01			

- (2) Specifications: Enclosed as Annexure-'A'
- (3) Components Drawings: Enclosed as Annexure-'B'
- (4) Special Conditions: Enclosed as Annexure-'C'
- (5) Tech. Comparison: Enclosed as Annexure-'D'
- (6) Bid Qualification & Selection Criteria: Enclosed as Annexure-'E'
- (7) Proforma for Supplier/Firm Enclosed as Annexure-'F'

Note:- **SINGLE STAGE-TWO ENVELOPE PROCEDURE:**

- i. The bid shall comprise a single package containing two envelopes. Each envelope shall contain separately the technical and financial proposal.
- ii. The envelope shall be marked as "Technical Proposal" & "Financial Proposal" in bold and legible letters to avoid confusion.
- iii. Initially, only the envelope marked "Technical Proposal" shall be opened.
- iv. The envelope marked as "Financial Proposal" shall be retained in the custody of Bid Centre.
- v. During the technical evaluation, no amendments in the technical proposal shall be permitted.
- vi. The financial proposals of bids shall be opened publicly at a time, date and venue announced and communicated to the bidders in advance.

(8) UNDERTAKING:

Should our offer be accepted, we hereby undertake to supply the stores/render the services contracted on the basis of Conditions of Contract embodied in Form POF 1282, and to deposit the performance bond within the prescribed time, failing which it will constitute a breach of contract, and POF will have the right to purchase the stores/services elsewhere at our risk and cost.

Place _____
Date _____

Signature of Tenderer _____
Name _____
Position _____
Address _____
Income Tax G.I.R No. _____

SPECIFICATION

a. Nomenclature

Surface Treatment Plant (Passivation)

Qty = 01 No

b. Technical Specifications

i.	Type	Chromate Passivation
ii.	Component	Brass
iii.	Passivation	To Spec DEF-STAN 03/12 Issue-2
iv.	Material of Tanks	Stainless Steel, Grade 304 or 316 with PVC or Polypropylene Lining (Internally & Externally)
v.	Process Layout	As per process sheet attached (SK/E-8080)
vi.	Tank Wall Thickness	8mm ± 0.5mm
vii.	Tank Coating / Lining Thickness	PVC or Polypropylene Lining 3mm (05 x years minimum life of lining)
viii.	Tank Size	L x W x H = 3 x 3 x 3
ix.	Max Operating Temp	120 °C
x.	No. of Tanks	14 Nos
xi.	Tank Stand Height	2 feet
xii.	Mounting Stands	Corrosion Resistant, Suitable for the Tanks
xiii.	Feeding System of components	Perforated Stainless Steel Baskets Dia : 1.5' Length: 1.5'
xiv.	Agitation system for homogenization of solution	Pneumatic or suitable
xv.	Fume Extraction System	Centrifugal Driven exhaust with hopper & ducting on chemical process tanks
xvi.	Heating System	Through Steam and Electric Heating
xvii.	Temperature sensor	Digital
xviii.	Stainless Steel Grating for Walkways	Length= As per layout Width = 5 feet Height = 1.5 feet
xix.	Drainage System	Separate drainage lines for each tank
xx.	Waste treatment and disposal	As per regulatory environmental regulation applicable in Pakistan
xxi.	Life of Equipment & Accessories	10 x Years (minimum)

c. Features

- i. Solution Level Controller
- ii. Automatic Temperature Control with Digital Meter
- iii. Spare immersion heaters as a backup heating source
- iv. pH Sensors / Probes for monitoring solution acidity
- v. Waste Treatment Plant / Neutralization for chemical waste

d. **Accessories**

- i. Perforated Stainless Steel Baskets, qty 30 Nos
- ii. Backup arrangement for tank coating for repair patches

e. **Tooling**

02 × Tooling kits for repair & maintenance

f. **Spares**

Electrical, Electronic & Mechanical spare parts for 5,000 operating hours of plant

g. **Documentation**

04 × sets of following documents for plant in English are required:-

- i. Electric Sequence Control Circuit Diagram of plant
- ii. Technical details of motors and their control
- iii. Operating, maintenance and service manual
- iv. Plant layout diagram will be provided by the firm well before shipment of plant
- v. Hydraulic & Pneumatic Control Drawings

h. **Site Condition & Available Services**

i. The available electric system on site for functioning of the Plant is:

- 400 ± 5% VAC, 50Hz, 3 Phase, 4-Wire System
- 230 ± 5% VAC, 50Hz, 1 Phase

ii. The available compressed air supply on site is 5 ~ 6 bar.

iii. The available climatic conditions for functioning of the Plant are :

a. Temperature:

- Winter = 0 to 25 °C
- Summer = 25 to 50 °C

b. Relative Humidity = 15 to 90%

i. **Safety**

Safety devices in accordance to international standards must include the followings:-

- i. Over Current Tripping System
- ii. Safety guards for rotary parts must be provided
- iii. Mechanical Overload Protection
- iv. Electric / Electronic Overload Protection
- v. The electric equipment should be earthed less than 01 ohm.
- vi. Equipment should have line protection circuit breakers with thermally delayed overload relays and or electro-magnetic quick-acting relays, as required.
- vii. It should be followed by cut-out and safety fuses, if necessary.
- viii. All motors should be appropriately protected as per IP standard.
- ix. The industrial electrical measuring instruments, wherever used should have an accuracy of Class-I or better.
- x. Emergency Stop Button

j. Operation Cycle Time

Operation cycle time of each component is required to be as follows:-

Sr #	Component	Drg #	Capacity per 07 hrs shift
a.	Body	SK/COM-8079	500 ~ 600 Nos each
b.	Head		
c.	Plunger		
d.	Screw		
e.	Plate		

k. Training

- i. Free of cost training for 02 x weeks of 10 x POF Officials on programming, operation and maintenance at OEM's premises.
- ii. Air tickets, Boarding / Lodging and DA expenses in respect of Training teams would be borne by purchaser.

l. Pre-shipment Inspection

- i. Pre-shipment inspection / acceptance of Plant at OEM's premises will be conducted by 03 x POF Officials for 01 x week starting from 2nd week of training. The inspection team besides others will particularly carry out trial run of the Plant and it will be considered acceptable subject to satisfactory plating of 100 x components each to Drg # SK/COM-8079 on the Plant.
- ii. Inspection of passivated components will be carried out through equipment for spot test as mentioned at Annex-C of Spec DEF-STAN 03-12 / Issue-2. Provisioning of testing facility will be arranged by OEM.
- iii. Despatch of semi finished component / material, gauges for trial run of the Plant at OEM's premises will be responsibility of the firm through firm's Local Rep.
- iv. Specified material will be used for production of components during PSI. The provisioning of material will be made by the OEM.
- v. Air tickets, Boarding / Lodging and DA expenses in respect of PSI teams would be borne by Purchaser.

m. Installation & Commissioning

- i. Installation & commissioning of the Plant is the responsibility of OEM.
- ii. POF will provide services and manpower to help during installation & commissioning.
- iii. All safety risks associated with installation & commissioning are the responsibility of OEM.
- iv. Needed material (Mechanical / Electrical) for installation & commissioning would be managed by the OEM.
- v. Plant layout diagram will be provided by OEM well before shipment of Plant.
- vi. The OEM will provide information regarding time schedule and total man-weeks of its engineers / technicians required for installation, commissioning and trial production run of the Plant. All expenses, including boarding & lodging, air travel and daily allowances of the engineers / technicians are to be borne by the supplier. However Local transportation shall be arranged by the purchaser.
- vii. During the warranty / guarantee period, any replacement of faulty Plant part will be responsibility of the OEM. The OEM will provide Plant part free of cost and without any obligation to the purchaser.

- viii. The Plant after installation and commissioning shall be accepted on firm’s warranty / guarantee. The warranty / guarantee shall be binding on the supplier for a period of 03 x Years reckoning from the date of FAT of the Plant.

n. Final Acceptance Test

- i. Final acceptance test will be performed at purchaser premises.
- ii. 1000 x components as per Drg # SK/COM-8079 will be passivated on the plant. Material will be provided by purchaser.
- iii. 100% inspection of produced components with zero rejection will be considered “Acceptable / Satisfactory”.
- iv. Based on successful inspection report, a certificate will be issued by purchaser in respect of successful installation and commissioning of the Furnace.
- v. The OEM will provide on job training on the Furnace to Engineers / Technicians at purchaser premises during installation & commissioning.

o. Delivery Schedule

- i. Delivery of the plant will be made within 06 x months from establishment of Letter of Credit.
- ii. Delivery of the plant will be made on C&F basis.

p. Country of Origin

Europe, UK, USA, Japan, South Korea, Pakistan & any other country manufacturing under the license of OEM

q. Colour

Green RAL-6011

DIMENSIONS IN INCHES
THIRD ANGLE PROJECTION.

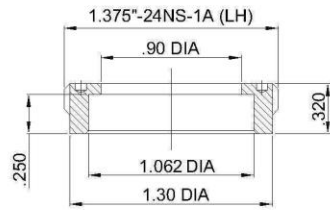

SCREW

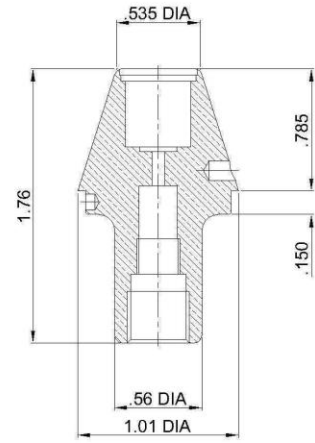

HEAD

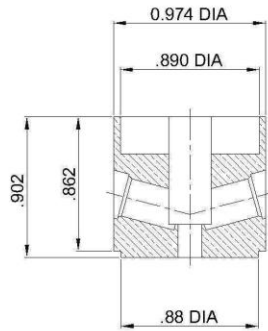

PLUNGER

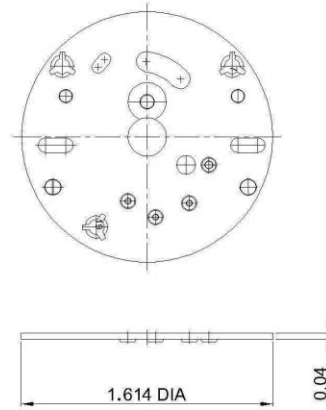

PLATE

MATERIAL:-
BRASS TO SPECN.
B.S. 2874 C 121.

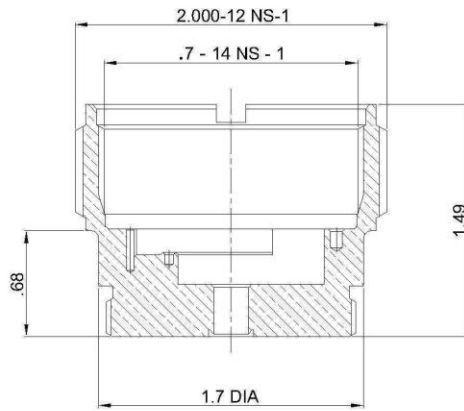

BODY

FOR PASSIVATION PLANT

SHEET:- 1 OF 1

DRAWN: M. AZEEM (A.T.O)

CHECKED: M. ANWAR (A.M)

APP'VD: GHUFRANULLAH (A.M)

DRG.No.

SK/COM-8079

DATE: 11 - 07 - 2024

LAYOUT PASSIVATION PLANT

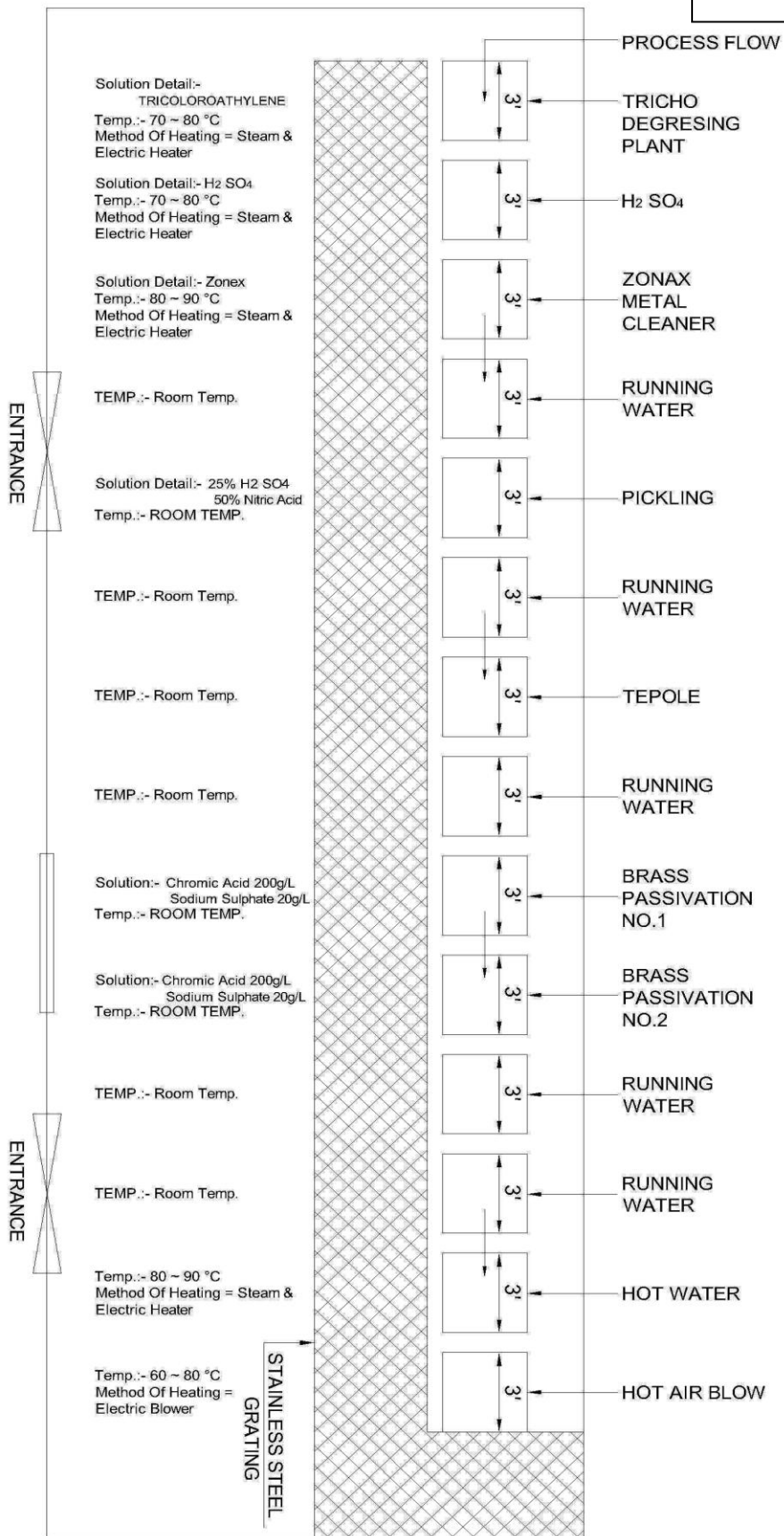

NOTES:-
TOTAL NO. OF TANKS. = 14

SHEET:- 1 OF 1

DRAWN:-	JUNAD RHALE (A.T.O)
CHECKED:-	M. ANWAR (A.M)
APP'VD:-	GURRANULLAH (A.M)
DRG. No.	SK/COM-8080
DATE:	14 - 11 - 2024

SPECIAL CONDITIONS**a) TO BE FULFILLED AT THE TIME OF BIDDING / REPLY OF TENDER ENQUIRY**

- i. It may be confirmed that you will be able to obtain export license from your Govt. in the event of successful bidding.
- ii. OEM/authorized suppliers with company profile/brochure.
- iii. Performance of such type of machine supplied to various customer.
- iv. Item wise price of machine, equipment & accessories alongwith Electrical, Electronic for control and Mechanical Spare Parts for 02 x years running maintenance should be quoted as part of commercial offer (Part-II). Essential maintenance & operational spares shall be supplied and ensure backup support for provisioning of spares for 15 years.
- v. Reference Column 2.2 of Tender Enquiry Form No. 1262, any indication whatsoever of the price in Part-I of the quotation will render it invalid and void.
- vi. The supplier must fill in the Proforma of Technical Comparison enclosed as Annexure-‘D’ to the specifications and submit along with the technical offer for our instant evaluation.
- vii. The supplier will provide necessary brochures and technical literature alongwith Part-I of the offer (Technical Offer).
- viii. POF shall deal directly with the manufacturer / supplier of the machine. In case of manufacturer / supplier chooses to have a local agent, payment of agent’s commission etc., shall be supplier’s responsibility and shall not be included in the price quoted in Part-II of the offer (Commercial Quotation). However, contract will be placed on principals / manufacturers.

b) CONDITIONS TO BE PART OF FORMAL CONTRACT AND MAY BE KEPT IN VIEW BEFORE BIDDING**a. For Foreign Supplier(Negotiable)**

Payment to the supplier will be made through irrecoverable letter of credit with the following terms and conditions which are negotiable:-

- i. 70% payment will be released through LC against shipping documents including Acceptance Certificate signed by PSI team, confirming satisfactory pre-shipment inspection.
- ii. 30% payment will be paid through LC upon final acceptance subject to the following certifications signed by Inspection Team and MD-AA:-
 - a. Upon receipt of the machines in POF Wah Cantt along with all spares, tooling accessories, lubricant, software, manual standard / catalogue.
 - b. Successful installation & commissioning of machine at POF premises and issuance of FAT certificate by POF.
 - c. Successful trial run and production of components on the machine as per FAT criteria.

iii. b. For Local Supplier

100% payment will be paid through cross cheque issued by CMA POF Wah upon final acceptance subject to the following certifications signed by Inspection Team and MD-AA:-

- a. Receipt of the machines in POF Wah Cantt along with all spares, tooling accessories, lubricant, software, manual standard / catalogue.
 - b. Successful installation & commissioning of machine at POF premises.
 - c. Successful Final Acceptance Test (F.A.T) requiring the specific Qty of Successful production/processing of the components as per requirement.
- iv. The manufacturer / supplier will train at his premises 10 x POF officials for 02 x Weeks on programming, operating and maintenance of Plant at OEM’s premises free of cost.

Contd...

- v. Pre-shipment inspection / acceptance of Plant at OEM's premises will be conducted by 03 x POF Officials for 01 x week starting from 2nd week of training. The inspection team besides others will particularly carry out trial run of the Plant and it will be considered acceptable subject to satisfactory plating of 100 x components each to Drg # SK/COM-8079 on the Plant.
- vi. Inspection of produced components will be carried out through gauges, SMEs and through enlargement where required. Provisioning of applicable gauges will be made by purchaser whereas arrangements for SMEs and enlargement will be made by supplier.
- vii. Air tickets for both sides, boarding & lodging, inland transportation and provisioning of payment of Daily Allowance in respect of training & PSI teams will be borne by POF.
- viii. The manufacturer / supplier will ensure supply of foundation drawings and installation manual to the consignee at least two months before shipment of the machine.
- ix. The plant will be installed and commissioned at POF by the supplier engineers 1000 x components as per Drg # SK/COM-8079 will be produced on the machine as per cycle time. Material will be provided by purchaser. Inspection of produced components will be carried out through gauges, SMEs and through enlargement where required Provisioning of applicable gauges will be made by purchaser.
- x. The manufacturer/supplier will undertake regarding backup support for provisioning of Mechanical, Electrical & Electronic Spare Parts for 15 years maintenance after commissioning of the machine as and when required by POF. The undertaking shall be furnished by the firm in the shape of a certificate to be issued on the letter head of the firm alongwith the accepted copies of the contract (to be returned to the buyer).
- xi. Four sets of document in English language Electric Sequence Control Circuit Diagram of plant, Technical details of motors and their control. Operating, maintenance and service manual, hydraulic & Pneumatic Control drawings. Machine layout diagram will be provided by the firm well before shipment of plant.
- xi. The manufacturer/supplier will provide performance bond in the shape of Bank Guarantee @ 10% of net FOB (LC) value which will be valid for 24 x months from the date of opening of letter of credit. The same will be got extended upto 12 x months after successful FAT of the machine.
- xii. The spare parts will be properly tagged with Part No. / Serial No. for identification.
- xiii. The machine must be packed in seaworthy packing and protected adequately & appropriately to the mode of dispatch against damages from water or other substances during sea voyage and over land journey to withstand the rough handling involved in transit and provide proper preservation of the machine while held in storage by the consignee.
- xiv. The machine must include complete tool kit for running & planned maintenance of the machine.
- xv. POF will hold no responsibility for any damage occurred during shipment of the machine.
- xvi. The supplier will provide on letter head duly signed and stamped declaration of fees, commissions & brokerage etc. along with the accepted copies of the contract.

Signature of the Supplier:

Name _____

Status in the Firm _____

Address _____

Place _____

Date _____

**TECHNICAL COMPARISON
(TO BE FILLED BY SUPPLIER)**

Sr. #	TENDER SPECIFICATIONS	OFFERED SPECIFICATIONS WITH REFERENCE TO PAGE NO. OF QUOTATION

BID QUALIFICATION & SELECTION CRITERIA

Sr #	Technical/Commercial aspects to be considered to ease out most advantageous bid	Compliance Level			Remarks
		Fully Complied	Partially Complied	Not Complied	
1*	Bid submitted in compliance with PPRA Rule 36(d)				
2*	Confirm to Tender Specification				
3*	Confirm Tender Quantity (s)				
4	Complete Technical literature/Brochure/catalogue provided in first go along with technical				
5.	Prices are valid for any reduced quantity(s) without notice				
6*	120 days bid validity from date of opening of commercial offers/bid confirmed				
7	Delivery period as per schedule of tender enquiry				
8	Payment terms as per tender enquiry				
9	In case of new entrant, proof of past performance/ list of identical supplies to prove capabilities in the relevant filed				
10*	Certificate regarding fulfillment of all tender				
11*	T.E undertaking-Signed/Stamped				
12*	Offer/Bid (Tech+Comm) is un conditional				
13*	Complete company profile				
14	Certificate that firm is not blacklisted or under debarment by any Govt/Semi Govt Organization				
15.	Confirmation of performance Bond against LC as per T.E Clause-7				
16*	Main Features as per Annex “A” of T.E				
17*	Technical Requirements as per Annex “A” of T.E				
18*	Site & Operating Conditions as per Annex “A” of T.E				
19*	Country of Origin as per Annex “A” of T.E				
20*	Specification for Electric Supply System as per as per				
21*	Literature Required as per Annex “A” of T.E				
22*	Additional Equipment as per Annex “A” of T.E				
23*	Terms & Conditions as per Annex “A” of T.E				
24*	Comply the Performa as per Annex “F” of T.E				
Note:- Clause with (*) are necessary to be complied. In case of non-compliance of the same, the bid may be disqualified					

Signature of the Tenderer with Stamp
Place _____
Date _____

Surface Treatment Plant (Passivation) Qty = 01 No

Supplier / Firm _____

Store Description	Compliance / Non-Compliance by the OEM	Remarks
a. Technical Specifications		
i. Type	Chromate Passivation	
ii. Component	Brass	
iii. Passivation	To Spec DEF-STAN 03/12 Issue-2	
iv. Material of Tanks	Stainless Steel, Grade 304 or 316 with PVC or Polypropylene Lining (Internally & Externally)	
v. Process Layout	As per process sheet attached (SK/E-8080)	
vi. Tank Wall Thickness	8mm ± 0.5mm	
vii. Tank Coating / Lining Thickness	PVC or Polypropylene Lining 3mm (05 × years minimum life of lining)	
viii. Tank Size	L × W × H = 3 × 3 × 3	
ix. Max Operating Temp	120 °C	
x. No. of Tanks	14 Nos	
xi. Tank Stand Height	2 feet	
xii. Mounting Stands	Corrosion Resistant, Suitable for the Tanks	
xiii. Feeding System of components	Perforated Stainless Steel Baskets Dia:1.5' length: 1.5'	
xiv. Agitation system for homogenization of solution	Pneumatic or suitable	
xv. Fume Extraction System	Centrifugal Driven exhaust with hopper & ducting on chemical process tanks	
xvi. Heating System	Through Steam and Electric Heating	
xvii. Temperature sensor	Digital	
xviii. Stainless Steel Grating for Walkways	Length = As per layout Width = 5 feet Height = 1.5 feet	
xix. Drainage System	Separate drainage lines for each tank	
xx. Waste treatment and disposal	As per regulatory environmental regulation applicable in Pakistan	
xxi. Life of Equipment & Accessories	10 × Years (minimum)	

b. Features		
i. Solution Level Controller		
ii. Automatic Temperature Control with Digital Meter		
iii. Spare immersion heaters as a backup heating source		
iv. pH Sensors / Probes for monitoring solution acidity		
v. Waste Treatment Plant / Neutralization for chemical waste		
c. Accessories		
i. Perforated Stainless Steel Baskets, qty 30 Nos		
ii. Backup arrangement for tank coating for repair patches		
d. Tooling		
02 x Tooling kits for repair & maintenance		
e. Spares		
Electrical, Electronic & Mechanical spare parts for 5,000 operating hours of plant		
f. Documentation		
04 x sets of following documents for plant in English are required:-		
i. Electric Sequence Control Circuit Diagram of plant		
ii. Technical details of motors and their control		
iii. Operating, maintenance and service manual		
iv. Plant layout diagram will be provided by the firm well before shipment of plant		
v. Hydraulic & Pneumatic Control Drawings		
g. Site Condition & Available Services		
i. The available electric system on site for functioning of the Plant is:		
• 400 ± 5% VAC, 50Hz, 3 Phase, 4-Wire System		
• 230 ± 5% VAC, 50Hz, 1 Phase		
ii. The available compressed air supply on site is 5 ~ 6 bar.		
iii. The available climatic conditions for functioning of the Plant are :		
a. Temperature:		
▪ Winter = 0 to 25 °C		
▪ Summer = 25 to 50 °C		
b. Relative Humidity = 15 to 90%		
h. Safety		
Safety devices in accordance to international standards must include the followings:-		
i. Over Current Tripping System		
ii. Safety guards for rotary parts must be provided		
iii. Mechanical Overload Protection		
iv. Electric / Electronic Overload Protection		
v. The electric equipment should be earthed less than 01 ohm.		
vi. Equipment should have line protection circuit breakers with thermally delayed overload relays and or electro-magnetic quick-acting relays, as required.		

vii. It should be followed by cut-out and safety fuses, if necessary.				
viii. All motors should be appropriately protected as per IP standard.				
ix. The industrial electrical measuring instruments, wherever used should have an accuracy of Class-I or better.				
x. Emergency Stop Button				
i. <u>Operation Cycle Time</u>				
Operation cycle time of each component is required to be as follows:-				
Component	Drg #	Capacity per 07 hrs shift		
Body	SK/COM-8079	500 ~ 600 Nos each		
Head				
Plunger				
Screw				
Plate				
j. <u>Training</u>				
i. Free of cost training for 02 x weeks of 10 x POF Officials on programming, operation and maintenance at OEM's premises.				
ii. Air tickets, Boarding / Lodging and DA expenses in respect of Training teams would be borne by purchaser.				
k. <u>Pre-shipment Inspection</u>				
i. Pre-shipment inspection / acceptance of Plant at OEM's premises will be conducted by 03 x POF Officials for 01 x week starting from 2 nd week of training. The inspection team besides others will particularly carry out trial run of the Plant and it will be considered acceptable subject to satisfactory plating of 100 x components each to Drg # SK/COM-8079 on the Plant.				
ii. Inspection of passivated components will be carried out through equipment for spot test as mentioned at Annex-C of Spec DEF-STAN 03-12 / Issue-2. Provisioning of testing facility will be arranged by OEM.				
iii. Despatch of semi-finished component / material, gauges for trial run of the Plant at OEM's premises will be responsibility of the firm through firm's Local Rep.				
iv. Specified material will be used for production of components during PSI. The provisioning of material will be made by the OEM.				
v. Air tickets, Boarding / Lodging and DA expenses in respect of PSI teams would be borne by Purchaser.				
l. <u>Installation & Commissioning</u>				
i. Installation & commissioning of the Plant is the responsibility of OEM.				
ii. POF will provide services and manpower to help during installation & commissioning.				

iii.	All safety risks associated with installation & commissioning are the responsibility of OEM.		
iv.	Needed material (Mechanical / Electrical) for installation & commissioning would be managed by the OEM.		
v.	Plant layout diagram will be provided by OEM well before shipment of Plant.		
vi.	The OEM will provide information regarding time schedule and total man-weeks of its engineers / technicians required for installation, commissioning and trial production run of the Plant. All expenses, including boarding & lodging, air travel and daily allowances of the engineers / technicians are to be borne by the supplier. However Local transportation shall be arranged by the purchaser.		
vii.	During the warranty / guarantee period, any replacement of faulty Plant part will be responsibility of the OEM. The OEM will provide Plant part free of cost and without any obligation to the purchaser.		
viii.	The Plant after installation and commissioning shall be accepted on firm’s warranty / guarantee. The warranty / guarantee shall be binding on the supplier for a period of 03 x Years reckoning from the date of FAT of the Plant.		
m. Final Acceptance Test			
i.	Final acceptance test will be performed at purchaser premises.		
ii.	1000 x components as per Drg # SK/COM-8079 will be passivated on the plant. Material will be provided by purchaser.		
iii.	100% inspection of produced components with zero rejection will be considered “Acceptable / Satisfactory”.		
iv.	Based on successful inspection report, a certificate will be issued by purchaser in respect of successful installation and commissioning of the Furnace.		
v.	The OEM will provide on job training on the Furnace to Engineers / Technicians at purchaser premises during installation & commissioning.		
n. Performance Bond			
i. For Foreign Supplier			
(a).	The successful bidder will provide Performance Bond in foreign currency at the rate of 10% of FOB value of the contract in favour of Controller of Military Accounts (CMA), Wah Cantt. The Performance Bond shall be furnished within 45 days from the date of opening of Letter of Credit. It shall be valid for a period of 24 months from the date of opening of letter of credit. The same will be got extended upto 12 x months after successful installation, commissioning & FAT of the machine accordingly. If the Performance Bond is not furnished within the above mentioned prescribed time, the Purchaser reserves the right to cancel the contract and make other arrangements for purchase of the machine at the risk and expense of the Supplier.		

(b). No Performance Bond will be required if the total FOB value of the contract is less than US \$ 50,000 and contract is placed directly on the foreign supplier.		
ii. For Local Supplier		
The Performance Bond will be furnished in local currency in the form of Deposit At Call Receipt (CDR) from any scheduled Bank in Pakistan or an unconditional bank guarantee on prescribed Proforma covered by any schedule bank in Pakistan.		
o. Payment Terms & Conditions		
i. For Foreign Supplier (Negotiable)		
Payment to the supplier will be made through irrevocable letter of credit with the following terms and conditions:-		
(a). 70% payment will be released through LC against shipping documents including Acceptance Certificate signed by PSI team, confirming satisfactory pre-shipment inspection.		
(b). 30% payment will be paid through LC upon final acceptance subject to the following certifications signed by Inspection Team and MD-AA:-		
iv. Receipt of the machines in POF Wah Cantt along with all spares, tooling accessories, lubricant, software, manual standard / catalogue.		
v. Successful installation & commissioning of machine at POF premises.		
vi. Successful Final Acceptance Test (F.A.T) requiring the specific Qty of Successful production/processing of the components as per requirement.		
Note:		
All Bank charges incurred in Pakistan in connection with the establishment of LC will be borne by the Purchaser, whereas all Bank charges incurred in connection with drawing of payment including charges for confirmation of LC by the advising Bank/Foreign Bank will be borne by the Supplier.		
ii. For Local Supplier		
100% payment will be paid through cross cheque issued by CMA POF Wah upon final acceptance subject to the following certifications signed by Inspection Team and MD-AA:-		
(a). Receipt of the machines in POF Wah Cantt along with all spares, tooling accessories, lubricant, software, manual standard / catalogue.		
(b). Successful installation & commissioning of machine at POF premises.		
(c). Successful Final Acceptance Test (F.A.T) requiring the specific Qty of Successful production/processing of the components as per requirement.		

p. <u>Delivery Schedule</u>		
i. Delivery of the machine will be made within 06 x months from establishment of Letter of Credit.		
ii. Delivery of the machine will be made on C&F basis.		
q. <u>Country of Origin</u>		
Europe, UK, USA, Japan, South Korea, Pakistan & any other country manufacturing under the license of OEM		
r. <u>Colour</u>		
Green RAL-6011		