



GOVERNMENT OF PAKISTAN
PAKISTAN ORDNANCE FACTORIES
TENDER ENQUIRY

To

Dear Sirs,

Reference: - TENDER ENQUIRY NO. 3521-2-32-54-FP-Capt-Pur-AA, dated 14-01-2025.

You are requested to submit sealed quotations for the item noted on the Schedule to the Tender. Please note the following instructions for filling the tender:-

1. **SUBMISSION OF TENDER**

- 1.1 Tenders will be opened at 1230 hours on 25-02-2025 and must reach at Bid Centre adjacent to Rabita Hall at least half an hour earlier than the opening time on same date. You may witness the opening of the tender if you so desired. If a representative is deputed, he should bring a letter of authority from you. The tender received late will not be entertained.
- 1.2 Only one tender should be included in one envelope. The outside of the envelope should be inscribed with: -

Tender Enquiry No: 3521-2-32-54-FP-Capt-Pur-AA, dated 14-01-2025

Tender to be opened on: 25-02-2025

Address as follows:-

**BID Centre Adjacent To Rabita Hall
Managing Director
Artillery Ammunition Factory
Pakistan Ordnance Factories,
Wah Cantt, Pakistan.
Fax : 051-9314100 & 051-9271400
Email : madaa@pof.gov.pk
gmservices-aa@pof.gov.pk**

- 1.3 If envelope do not indicate reference of TE or received late, the same will be returned un-opened.

Contd...

1.4 **EVALUATION CRITERIA.**

All the technical proposals will be evaluated / scrutinized initially and commercial Proposals of only those bidders will be opened who will be technically prequalified / accepted. Accordingly, Order / Contract will be awarded to most advantageous bidder on the basis of bid qualification criteria (Annex-E).

2. **GENERAL INSTRUCTIONS REGARDING PREPARATION OF QUOTATIONS**

2.1 For Plant & Machinery, you are required to quote in two parts:-

Part-I "TECHNICAL OFFER" It should exclusively give technical details and literatures/brochures of the offered plant, machinery and equipment; validity date; delivery schedule; and signed undertaking given on the schedule to this Tender Enquiry and country of origin should be clearly mentioned. It must not indicate price, costs etc.

Part-II "COMMERCIAL OFFER" It should indicate the commercial terms e.g. price, terms of payment, mode of payment, mode of supply.

Each part should be placed in a separate sealed cover. The envelope should be inscribed with Part-I "Technical Quotation without Price" and Part-II "Commercial Quotation with Price".

- 2.2 The Tendering procedure as laid down in PPRA Rule No. 36(b) i.e. Single Stage two envelopes will be applicable.
- 2.3 The quotation must remain valid for, at least 120 days from the date of opening of tenders (Commercial Offers).
- 2.4 The quotation should hold good for any reduced or enhanced quantities without notice.
- 2.5 In the event of non-acceptance of offer, intimation may be given to the Tenders on their request.
- 2.6 Conditional offers or alternative offers are likely to be ignored.
- 2.7 Quotations should be based on FOB. The consignment will be shipped through Pakistan National Shipping Corporation (PNSC). In case there is no PNSC service in the country of shipping, please quote on C & F basis. The freight should be indicated separately. Insurance premium should not be included in the quoted price. However, where insurance is considered necessary, advice to that effect should be given in the quotation.
- 2.8 Submission of the offer through an agent in Pakistan should be avoided. In case it is considered inevitable, the agent's quotation must invariably be accompanied by the original proforma invoice from the principals/ manufacturers. **However, contract will be placed on principals / manufacturers.**
- 2.9 Country of origin and port of shipment to be stated.
- 2.10 The offer of principal must clearly indicate whether the rate quoted is inclusive of agent's commission, and if inclusive rate of commission included be specified.
- 2.11 Supplier will render necessary information regarding hazardous effects on environment, of the materials/products supplied by them, in their quotations and shipping/dispatch documents.
- 2.12 The Supplier will furnish a declaration regarding fees, commission and brokerage / environmental effect etc payable by the firm along with shipping documents.
- 2.13 If the requisite information is not furnished on the TE form or offer received is not in conformity with the requirement of the TE, the offer shall be ignored.

Contd...

3. **INSPECTION**

- 3.1 Pre-shipment inspection / acceptance of machine at OEM's premises will be conducted by 04 × POF Officials for 02 × weeks. The inspection team will execute thorough inspection of machine & will particularly carry out trial run of the machine and it will be considered acceptable subject to satisfactory production of 50 × components as per Drg # SK/COM-06 on the machine as per time cycle.
- 3.2 The machine after installation and commissioning will be accepted on firm's warranty / guarantee. The warranty / guarantee will be binding on the supplier for a period of 12 x months reckoning from the date of successful FAT of the machine as per criteria

4. **ACCEPTANCE OF OFFERS**

- 4.1 The procuring agency may reject all bids or proposals at any time prior to the acceptance of a bid or proposal. The procuring agency shall upon request communicate to any supplier or contractor who submitted a bid or proposal, the grounds for its rejection of all bids or proposals, but is not required to justify those grounds.
- 4.2 Procuring agency shall incur no liability, solely by virtue of its invoking sub-rule (1.1) towards suppliers or contractors who have submitted bids or proposals.
- 4.3 Notice of the rejection of all bids or proposals shall be given promptly to all suppliers or contractors that submitted bids or proposals.

5. **BID SECURITY**

- 5.1 A copy of bid security should accompany the tender in shape of deposit at call receipt / Pay order / Banker Cheque from schedule bank drawn in favour of **GM-Maint & SVS-AA (POF Wah Cantt)**.
- 5.2 Bid Security Instrument in original must accompany with the commercial offer as under:-
 - i. Registered / indexed firms including foreign firms – 2% of quoted value subject to max ceiling of Rs. 0.50 Mn.
 - ii. Registered / un-indexed firms including foreign firms – 3% of quoted value subject to max ceiling of Rs. 0.75 Mn.
 - iii. Un-registered firms including foreign firms – 5% of quoted value subject to max ceiling of Rs. 1.00 Mn.
 - iv. Government organization / production units / state owned enterprises / welfare projects of Svcs HQ – Rs. 50 Mn. can be waived off on request by DG(C).
 - v. Bid money will be returned to un successful (less first three lowest quote firms) bidders on opening of commercial offers.
 - vi. Bid money will be returned to successful bidder on submission of performance bond / unconditional BG.
 - vii. Quotation accompanied with less bid money will be accepted on provisional basis for 10 x days after opening of bids. However, the firms are bound to provide / furnish the balance bid money within 10 x days after opening of bid otherwise such quotations will be ignored or rejected.
 - viii. Offers received without bid security will not be entertained.
 - ix. Bid money will be forfeited in case the quotation is withdrawn before the expiry of its validity date.

Contd...

6. **PERFORMANCE BOND**

- (a) The successful bidder will provide Performance Bond at the rate of 10% of FOB value of the contract in favour of Controller of Military Accounts (CMA), Wah Cantt. The Performance Bond will be furnished in the form of Deposit At Call Receipt (CDR) from any scheduled Bank in Pakistan or an unconditional bank guarantee on prescribed Proforma covered by any schedule bank in Pakistan. The Performance Bond shall be furnished within 45 days from the date of opening of Letter of Credit. It shall be valid for a period of 12 months from the date of expiry of letter of credit. The same will be got extended upto 12 x months after successful FAT of the machine. If the Performance Bond is not furnished within the above mentioned prescribed time, the Purchaser reserves the right to cancel the contract and make other arrangements for purchase of the machine at the risk and expense of the Supplier.
- (b) No Performance Bond will be required if the total FOB value of the contract is less than US \$ 50,000 and contract is placed directly on the foreign supplier.

7. **FAILURE TO SUPPLY THE STORES**

All deliveries must be completed by the specified date. If the failure to deliver the stores within the scheduled time should have arisen from "Force Majeure", which the Purchaser may admit as reasonable ground for further time, he will allow such additional time as he may consider to have been required by the circumstances of the case. Otherwise, he will be entitled, at his discretion, to cancel the contract; and/or, claim liquidated damages upto 2% but not less than 1% of the contract price of the items and their quantities for each and every month or part of a month, beyond the specified delivery date, during which these may not be delivered, subject to a maximum of 10% of the total contract value of particular store which remained unsupplied either in part or in full or, to purchase, from elsewhere, the unsupplied stores at the risk and cost of the Supplier.

8. **PAYMENT**

Payment to the supplier will be made through irrecoverable letter of credit with the following terms and conditions which are negotiable:-

- i. 70% payment will be released through LC against shipping documents including Acceptance Certificate signed by PSI team, confirming satisfactory pre-shipment inspection.
- ii. 30% payment will be paid through LC upon final acceptance subject to the following certifications signed by Inspection Team and MD-AA:-
 - a. Upon receipt of the machines in POF Wah Cantt along with all spares, tooling accessories, lubricant, software, manual standard / catalogue.
 - b. Successful installation & commissioning of machine at POF premises and issuance of FAT certificate by POF.
 - c. Successful trial run and production of components on the machine as per FAT criteria.

All Bank charges incurred in Pakistan in connection with the establishment of LC will be borne by the Purchaser, whereas all Bank charges incurred in connection with drawing of payment including charges for confirmation of LC by the advising Bank/Foreign Bank will be borne by the Supplier.

Contd...

9. **ARBITRATION**

All matters of dispute or difference, except regarding rejection of stores by the inspector and / or cancellation of contract by the purchaser arising out of this agreement between the parties hereto, the settlement of which is not otherwise specially provided for in this agreement, shall be referred for adjudication to two arbitrators, one to be named by each party, who before entering upon the reference shall appoint an umpire by mutual agreements, and if they do not agree a judge of superior court shall appoint the umpire, the arbitration proceeding shall be held in Pakistan under the Pakistani law. The arbitration awards shall be un-spoken.

10. **SECURITY OF INFORMATION**

The tenderer and his employees must not communicate any information relating to the sale/purchase of stores under this enquiry to any person other than the manufacturer or to any press or agent not authorized in writing by POFs to receive it.

Please return the Schedule to the Tender duly signed by the specified date, along with the specifications drawings etc. if any, enclosed herewith - even if you are unable to quote.

WARNING

In case the firm abstain from making offers or fail to return/acknowledge the tender form by the specified date on three consecutive occasions, no further tender enquiry may be issued to them and their names would liable to be removed from the approved list.

NOTE:

Offers / bids through **Email & Fax** are not acceptable. The offers / bids must be submitted with warranty / guarantee certificate on firm's original letter head pad through **Mail / Courier**.

Yours faithfully,

(Munir Ahmad Naper)
Managing Director-AA

For and on behalf of the President
of Islamic Republic of Pakistan

Tele: 0092-51-905521035, 0092-51-905521301

Fax: 0092-51-9271400

PAKISTAN ORDNANCE FACTORIESSCHEDULE TO TENDER NO. 3521-2-32-54-FP-Capt-Pur-AA, dated 14-01-2025**(1) FOR PLANT AND MACHINERY**

(1)	(2)	(3)	(4)	(5)		(6)
Item No.	Description with Specs etc.	Unit	Qty.	Price Per Unit (FOB Value)		Delivery Date
				In Figures	In Words	
1	5 Head, Multi Spot Welding Machine	No.	01			

- (2) Specifications: Enclosed as Annexure-'A'
 (3) Components Drawings: Enclosed as Annexure-'B'
 (4) Special Conditions: Enclosed as Annexure-'C'
 (5) Tech. Comparison: Enclosed as Annexure-'D'
 (6) Bid Qualification & Selection Criteria: Enclosed as Annexure-'E'

Note:- SINGLE STAGE-TWO ENVELOPE PROCEDURE:

- The bid shall comprise a single package containing two envelopes. Each envelope shall contain separately the technical and financial proposal.
- The envelope shall be marked as "Technical Proposal" & "Financial Proposal" in bold and legible letters to avoid confusion.
- Initially, only the envelope marked "Technical Proposal" shall be opened.
- The envelope marked as "Financial Proposal" shall be retained in the custody of Bid Centre.
- During the technical evaluation, no amendments in the technical proposal shall be permitted.
- The financial proposals of bids shall be opened publicly at a time, date and venue announced and communicated to the bidders in advance.

(5) UNDERTAKING:

Should our offer be accepted, we hereby undertake to supply the stores/render the services contracted on the basis of Conditions of Contract embodied in Form POF 1282, and to deposit the performance bond within the prescribed time, failing which it will constitute a breach of contract, and POF will have the right to purchase the stores/services elsewhere at our risk and cost.

Place _____
 Date _____

Signature of Tenderer _____
 Name _____
 Position _____
 Address _____
 Income Tax G.I.R No. _____

Specifications

a. Nomenclature

5 Head, Multi Spot Welding Machine Qty = 01 No.

b. Working / concept of Spot Welding machine

- i. Machine will consist of 05 x pneumatic cylinders to hold and actuate Copper based electrodes / welding heads.
- ii. Underside Working table will consist of Index Beam, component location Jig, Current Carrying Side Clamp Unit and Ejector Unit.
- iii. Top side of table will be equipped with top clamp & component locator
- iv. 05 x water cooled transformers are also mounted on the lower table.
- v. One side of each transformer's secondary is connected to side clamps and the other side to each of 05 x welding Heads.
- vi. Machine is pneumatically operated with Weld Control Timers, Control Circuit Relays and Selector Switches etc
- vii. Machine should consist of 05 x Spot Welding Electrodes each having its Welding Transformer, Solid State Contactor and Welding Control Timer.
- viii. Electrical phase shift control is also a compulsory part of machine.
- ix. The control of the primary supply is via a special purpose, Solid State Welding Control Combination comprising of 05 x thyristor contactors, 05 x digital synchronic dual phase shift heat controls

c. Component Specification

The machines will be used for manufacturing of following component drawing:

Components to be manufactured / Drawing No.	Output of the machine
SK/COM-06 Attached as Annexure - B	Minimum 120,000 Nos. per annum are to be spot welded in 2000 working hours per annum. (Time cycle = 60 sec)

d. Machine Controls

Sr. #	Feature(s)	Parameters
i.	Type	Solid State Digital Control with Solid State Contactor, Weld Control Timers, Electrical Phase Shift Control and 05 x digital synchronic dual phase shift heat controls.
ii.	Trigger/Current up-slope	Foot switch or hand control.
iii.	Display	HMI based control and indication panel.

e. **Technical Specification**

Sr.#	Feature(s)	Parameters
i.	Number welding heads	5 Nos.
ii.	Tip Diameter	5 mm
iii.	Transformer Cooling Type	Oil / Water Cooled
iv.	Materials to be welded	BS 970 Pt-3 Steel 070 M20 (Cartg Cont) (Hot Rolled + Cold Drawn) and MS Sheet 16 BG BS EN 10132-3-2000 C22E (Fin)
v.	Primary Current	80 amp / as per OEM
vi.	Secondary current	6500 amp / as per OEM
vii.	Electrode material	Chrome Copper
	Welder rating	5 x 45 KVa max.
viii.	Primary Voltage	415 Volts
ix.	Welding Air Pressure	5 Bars max.
x.	Fixtures	As per drawing SK/COM-08
xi.	Color of Machine	Green RAL6011
xii.	Control Cabinets cooling system	
xiii.	Auto Ejector for welded component	

f. **Tooling**

- i. 02 x Tool Kit for running & planned maintenance of machine
- ii. Provision of welding electrodes and fixtures for 2000 working hours

g. **Spares**

- i. All kinds of Electrical, Electronic & Mechanical spare parts for 02 x years
- ii. Backup support for provisioning of spares for 15 x years

h. **Documentation**

04 x sets of following documents in English Language are required:

- i. Electric Sequence Control Circuit Diagram of machine
- ii. Operating, maintenance and service manual
- iii. Machine layout diagram will be provided by the firm well before shipment of machine

i. **Site Condition & Available Services**

The available electric system on site for functioning of the machine is:

- 400 ± 5% VAC, 50Hz, 3 Phase, 4-Wire System
- 220 ± 5% VAC, 50Hz, 1 Phase, 2-Wire System

The available compressed air supply on site for functioning of the machine is 5 +1 Bar

- The available process water at 40 PSI and at 200 ± 50 C
- Relative Humidity = 25 to 90%
- Earthquake Value = 7.0 on Richter scale

j. Safety

Safety devices in accordance to international standards must include the following:

- i. Over Current / Voltage Tripping System
- ii. Safety guards for moving parts must be provided
- iii. Electronic Overload Protection
- iv. The electric equipment should be earthed.
- v. Equipment should have line protection circuit breakers with electronic overload relays along with electro-magnetic contactors, as required. It should be followed by cut-out and safety fuses, if necessary.
- vi. All equipment should be equipped with all standard safety protections and fulfill IP42 or above ratings.

k. Operation Cycle Time

- i. 60 sec or less per component
- ii. Minimum production of 120,000 components per annum per machine for 2000 working hours (Single shift)
- iii. OEM will work out and provide machine cycle time study for component as per attached component drawing with technical offer

l. Training

- i. Free of cost training for 02 x weeks of 04 x POF officials on operations, control and electrical / mechanical maintenance.
- ii. All expenses including air tickets, boarding / lodging and DA in respect of training team will be borne by purchaser.

m. Pre-shipment Inspection

- i. Pre-shipment inspection / acceptance of machine at manufacturer's / OEM's premises will be conducted by 04 X POF Officials for 02 x weeks. The inspection team will execute thorough inspection of machines & will particularly carry out trial run of the machine and it will be considered acceptable subject to satisfactory production of 50 x components as per Drg # SK/COM-06 on the machine as per time cycle.
- ii. Inspection of produced components will be carried out through gauges, SMEs and through enlargement where required. Provisioning of applicable gauges will be made by purchaser whereas arrangements for SMEs and enlargement will be made by supplier. Moreover, components will be inspected through load test as per Drg # SK/COM-06 (575 kg - min).
- iii. 100% inspection of produced components with zero rejection and as per defined time cycle will be considered "Acceptable / Satisfactory".
- iv. Specified material will be used for production of components during PSI.
- v. The provisioning of input components will be made by purchaser. However, dispatch of such materials from premises of purchaser to premises of manufacturer will be the responsibility of supplier.
- vi. All expenses including air tickets, boarding / lodging and DA in respect of PSI teams will be borne by purchase

n. Installation & Commissioning

- i. Installation & commissioning of the machine is the responsibility of supplier
- ii. POF will provide utilities and labour to help during installation & commissioning
- iii. All safety risks associated with installation & commissioning will be the responsibility of supplier
- iv. Requisite materials (Mechanical / Electrical) for installation & commissioning will be managed by the supplier
- v. Machine layout diagram will be provided by the firm well before shipment of machine to prepare civil structure (if required)
- vi. The supplier will provide information regarding time schedule and total man-weeks of its engineers / technicians required for installation, commissioning and trial production run of the machine. All expenses, including boarding & lodging, air travel and daily allowances of the engineers / technicians will be borne by the supplier. However Local transportation shall be arranged by the purchaser
- vii. The machine after installation and commissioning will be accepted on firm's warranty / guarantee. The warranty / guarantee will be binding on the supplier for a period of 12 x months reckoning from the date of successful FAT of the machine as per criteria

o. Final Acceptance Test (FAT)

- i. Final acceptance test will be performed at purchaser premises.
- ii. Trial run of machine will be carried out to check abnormal noise, vibration, overheating, leakages & time cycle of the component to be machined etc.
- iii. Machine precision will be checked as per following criteria:
 - a. Mechanical fixtures accuracy
 - b. Welding spots accuracy
 - c. Load test as per Drg # SK/COM-06 (575 kg - min)
- iv. 2000 X components each as per Drg # SK/COM-06 will be produced on the machine as per given cycle time. Material will be provided by purchaser. Inspection of produced components will be carried out through gauges, SMEs and through enlargement where required Provisioning of applicable gauges will be made by purchaser
- v. 100% inspection of produced components with zero rejection and load test as per Drg # SK/COM-06 (575 kg - min), as per defined time cycle will be considered "Acceptable / Satisfactory"
- vi. Based on successful inspection report, a certificate will be issued by purchaser in respect of successful installation and commissioning of the machine
- vii. The firm will provide on job training on the machine to POF officials at purchaser premises during installation & commissioning

p. Delivery Schedule

- i. Delivery of the machine will be made within 06 x months after establishment of LC.
- ii. Delivery of the machine will be made on C&F basis.

q. Country of Origin

Europe, UK, USA, Japan, Turkiye & South Korea or any other country having license from OEMs of these origins for machine manufacturing.

WELDING PART

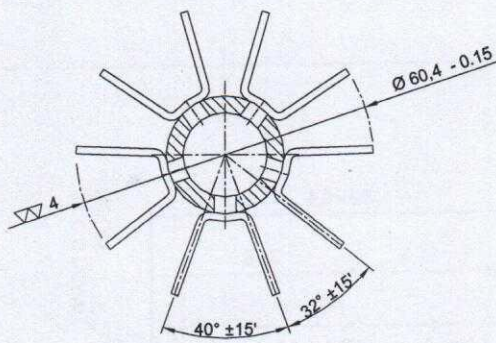
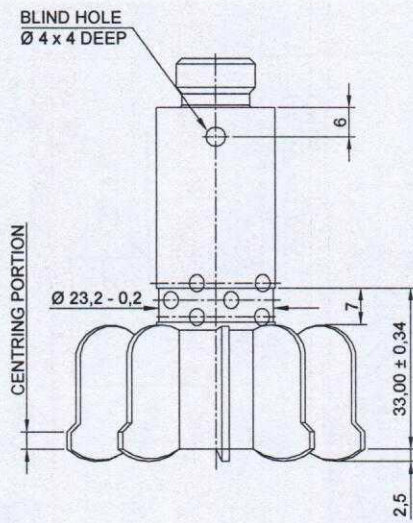
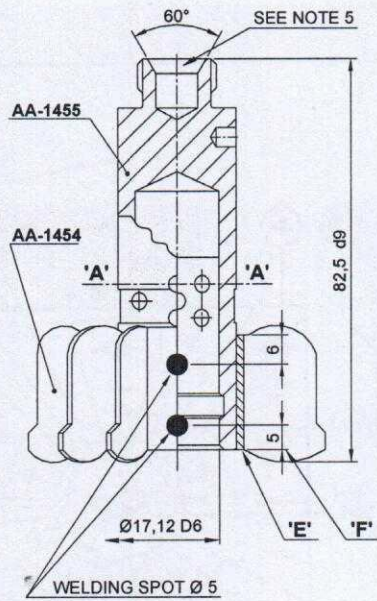

SEC. 'A A'

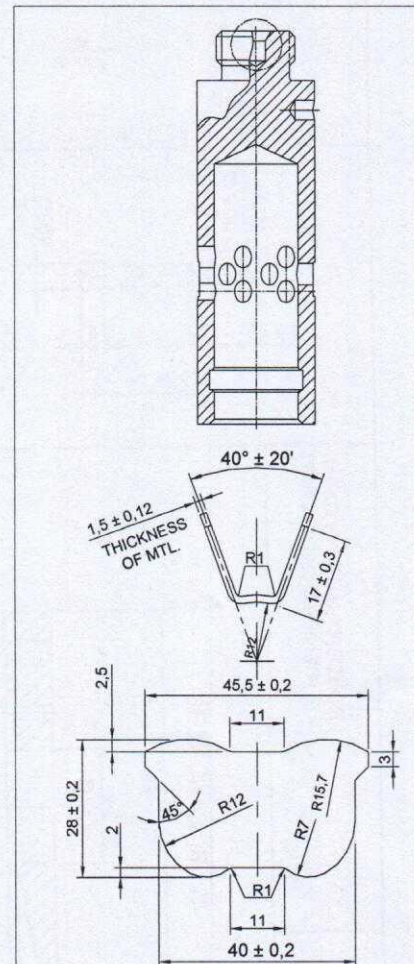

A FIN SHOULD NOT GET DETACHED WHEN SUBJECTED TO PULL TEST UNDER A LOAD OF 575 KG.

DIMENSIONS ARE IN MM
THIRD ANGLE PROJECTION

SK/ COM - 06

WELDING FIXTURE
FOR FINAL PART # 02

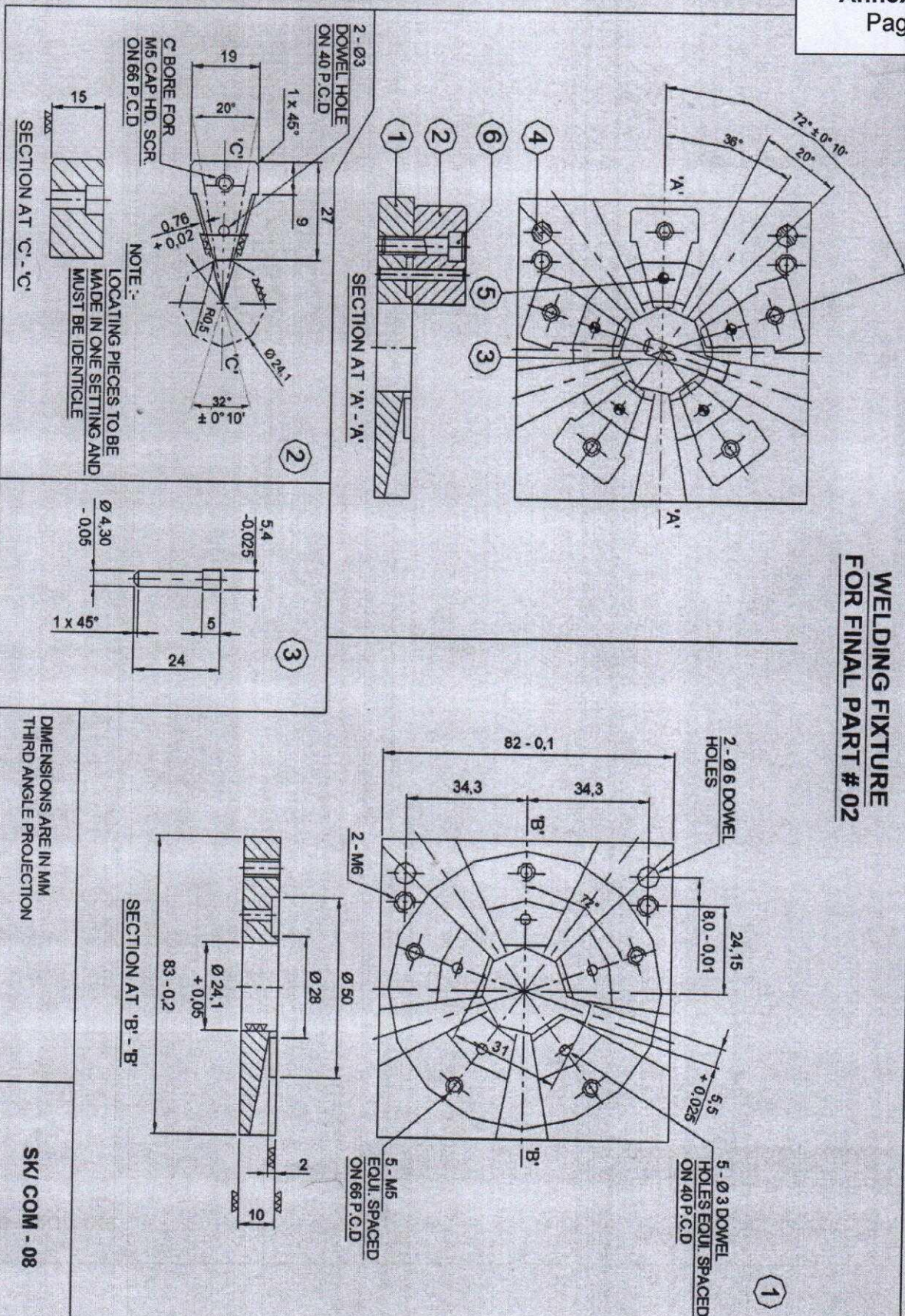

SPECIAL CONDITIONS**a) TO BE FULFILLED AT THE TIME OF BIDDING / REPLY OF TENDER ENQUIRY**

- i. It may be confirmed that you will be able to obtain export license from your Govt. in the event of successful bidding.
- ii. OEM/authorized suppliers with company profile/brochure.
- iii. Performance of such type of machine supplied to various customer.
- iv. Item wise price of machine, equipment & accessories alongwith Electrical, Electronic for control and Mechanical Spare Parts for 02 x years running maintenance should be quoted as part of commercial offer (Part-II). Essential maintenance & operational spares shall be supplied and ensure backup support for provisioning of spares for 15 years.
- v. Reference Column 2.2 of Tender Enquiry Form No. 1262, any indication whatsoever of the price in Part-I of the quotation will render it invalid and void.
- vi. The supplier must fill in the Proforma of Technical Comparison enclosed as Annexure-'D' to the specifications and submit along with the technical offer for our instant evaluation.
- vii. The supplier will provide necessary brochures and technical literature alongwith Part-I of the offer (Technical Offer).
- viii. POF shall deal directly with the manufacturer / supplier of the machine. In case of manufacturer / supplier chooses to have a local agent, payment of agent's commission etc., shall be supplier's responsibility and shall not be included in the price quoted in Part-II of the offer (Commercial Quotation). However, contract will be placed on principals / manufacturers.

b) CONDITIONS TO BE PART OF FORMAL CONTRACT AND MAY BE KEPT IN VIEW BEFORE BIDDING

- Payment to the supplier will be made through irrevocable letter of credit with the following terms and conditions which are negotiable:-
- i. 70% payment will be released through LC against shipping documents including Acceptance Certificate signed by PSI team, confirming satisfactory pre-shipment inspection.
 - ii. 30% payment will be paid through LC upon final acceptance subject to the following certifications signed by Inspection Team and MD-AA:-
 - a. Upon receipt of the machines in POF Wah Cantt along with all spares, tooling accessories, lubricant, software, manual standard / catalogue.
 - b. Successful installation & commissioning of machine at POF premises and issuance of FAT certificate by POF.
 - c. Successful trial run and production of components on the machine as per FAT criteria.
 - iii. The manufacturer / supplier will train at his premises 04 x POF officials for 02 x Weeks on programming, operating and maintenance/troubleshooting of machine at OEM's premises free of cost.
 - iv. Pre-shipment inspection / acceptance of machine at OEM's premises will be conducted by 04 x POF Officials for 02 x weeks. The inspection team besides others will particularly carry out trial run of the machines and it will be considered acceptable subject to satisfactory production of 50 x components as per Drg # SK/COM-06 on the machine.
 - v. Inspection of produced components will be carried out through gauges, SMEs and through enlargement where required. Provisioning of applicable gauges will be made by purchaser whereas arrangements for SMEs and enlargement will be made by supplier. Moreover, components will be inspected through load test as per Drg # SK/COM-06 (575 kg - min).

Contd...

- vi. Air tickets for both sides, boarding & lodging, inland transportation and provisioning of payment of Daily Allowance in respect of training & PSI teams will be borne by POF.
- vii. The manufacturer / supplier will ensure supply of foundation drawings and installation manual to the consignee at least two months before shipment of the machine.
- viii. The machine will be installed and commissioned at POF by the supplier engineers 2000 x components as per Drg # SK/COM-06 will be produced on the machine as per cycle time. Material will be provided by purchaser. Inspection of produced components will be carried out through gauges, SMEs and through enlargement where required Provisioning of applicable gauges will be made by purchaser.
- ix. The manufacturer/supplier will undertake regarding backup support for provisioning of Mechanical, Electrical & Electronic Spare Parts for 15 years maintenance after commissioning of the machine as and when required by POF. The undertaking shall be furnished by the firm in the shape of a certificate to be issued on the letter head of the firm alongwith the accepted copies of the contract (to be returned to the buyer).
- x. Four sets of document in English language Electric Sequence Control Circuit Diagram of machine, Operating, maintenance and service manual, Machine layout diagram will be provided by the firm well before shipment of machine. These manuals must include comprehensive instructions regarding Operation and Maintenance containing detailed Electrical, Electronic, of the machine supplied.
- xi. The manufacturer/supplier will provide performance bond in the shape of Bank Guarantee @ 10% of net FOB (LC) value which will be valid for 12 x months after the date of expiry of letter of credit. The same will be got extended upto 12 x months after successful FAT of the machine.
- xii. The spare parts will be properly tagged with Part No. / Serial No. for identification.
- xiii. The machine must be packed in seaworthy packing and protected adequately & appropriately to the mode of dispatch against damages from water or other substances during sea voyage and over land journey to withstand the rough handling involved in transit and provide proper preservation of the machine while held in storage by the consignee.
- xiv. The machine must include complete tool kit for running & planned maintenance of the machine.
- xv. POF will hold no responsibility for any damage occurred during shipment of the machine.
- xvi. The supplier will provide on letter head duly signed and stamped declaration of fees, commissions & brokerage etc. along with the accepted copies of the contract.

Signature of the Supplier:

Name _____

Status in the Firm _____

Address _____

Place _____

Date _____

**TECHNICAL COMPARISON
(TO BE FILLED BY SUPPLIER)**

Sr. #	TENDER SPECIFICATIONS	OFFERED SPECIFICATIONS WITH REFERENCE TO PAGE NO. OF QUOTATION

BID QUALIFICATION & SELECTION CRITERIA

Sr #	Technical/Commercial aspects to be considered to ease out most advantageous bid	Compliance Level			Remarks
		Fully Complied	Partially Complied	Not Complied	
1*	Bid submitted in compliance with PPRA Rule 36(d)				
2*	Confirm to Tender Specification				
3*	Confirm Tender Quantity (s)				
4	Complete Technical literature/Brochure/catalogue provided in first go along with technical				
5.	Prices are valid for any reduced quantity(s) without notice				
6*	120 days bid validity from date of opening of commercial offers/bid confirmed				
7	Delivery period as per schedule of tender enquiry confirmed				
8	Payment terms as per tender enquiry				
9	In case of new entrant, proof of past performance/ list of identical supplies to prove capabilities in the relevant filed				
10*	Certificate regarding fulfillment of all tender requirements				
11*	T.E undertaking-Signed/Stamped				
12*	Offer/Bid (Tech+Comm) is un conditional				
13*	Complete company profile				
14	Certificate that firm is not blacklisted or under debarment by any Govt/Semi Govt Organization				
15.	Confirmation of performance Bond against LC as per T.E Clause-15				
16*	Main Features as per Annex "A" of T.E				
17*	Technical Requirements as per Annex "A" of T.E				
18*	Site & Operating Conditions as per Annex "A" of T.E				
19*	Country of Origin as per Annex "A" of T.E				
20*	Specification for Electric Supply System as per as per Annex-A				
21*	Literature Required as per Annex "A" of T.E				
22*	Additional Equipment as per Annex "A" of T.E				
23*	Terns & Conditions as per Annex "A" of T.E				

Note:- Clause with (*) are necessary to be complied. In case of non-compliance of the same, the bid may be disqualified

Signature of the Tenderer with Stamp

Place-----

Date-----