



GOVERNMENT OF PAKISTAN
PAKISTAN ORDNANCE FACTORIES
TENDER ENQUIRY

To

Dear Sirs,

Reference: - TENDER ENQUIRY NO. 3521-2-2-54-FP-Capt-Pur-AA, dated 08-11-2024

You are requested to submit sealed quotations for the item noted on the Schedule to the Tender. Please note the following instructions for filling the tender:-

1. **SUBMISSION OF TENDER**

- 1.1 Tenders will be opened at 1230 hours on 31-12-2024 and must reach at Bid Centre adjacent to Rabita Hall at least half an hour earlier than the opening time on same date. You may witness the opening of the tender if you so desired. If a representative is deputed, he should bring a letter of authority from you. The tender received late will not be entertained.
- 1.2 Only one tender should be included in one envelope. The outside of the envelope should be inscribed with: -

Tender Enquiry No: 3521-2-2-54-FP-Capt-Pur-AA, dated 08-11-2024

Tender to be opened on: 31-12-2024

Address as follows:-

**BID Centre Adjacent To Rabita Hall
Managing Director
Artillery Ammunition Factory
Pakistan Ordnance Factories,
Wah Cantt, Pakistan.
Fax : 051-9314100 & 051-9271400
Email : mdaa@pof.gov.pk**

- 1.3 If envelope do not indicate reference of TE or received late, the same will be returned un-opened.

Contd...

1.4 **EVALUATION CRITERIA.**

All the technical proposals will be evaluated / scrutinized initially and commercial Proposals of only those bidders will be opened who will be technically prequalified / accepted. Accordingly, Order / Contract will be awarded to most advantageous bidder on the basis of bid qualification criteria (Annex-E).

2. **GENERAL INSTRUCTIONS REGARDING PREPARATION OF QUOTATIONS**

2.1 For Plant & Machinery, you are required to quote in two parts:-

Part-I "TECHNICAL OFFER" It should exclusively give technical details and literatures/brochures of the offered plant, machinery and equipment; validity date; delivery schedule; and signed undertaking given on the schedule to this Tender Enquiry and country of origin should be clearly mentioned. It must not indicate price, costs etc.

Part-II "COMMERCIAL OFFER" It should indicate the commercial terms e.g. price, terms of payment, mode of payment, mode of supply.

Each part should be placed in a separate sealed cover. The envelope should be inscribed with Part-I "Technical Quotation without Price" and Part-II "Commercial Quotation with Price".

- 2.2 The Tendering procedure as laid down in PPRA Rule No. 36(b) i.e. Single Stage two envelopes will be applicable.
- 2.3 The quotation must remain valid for, at least 120 days from the date of opening of tenders (Commercial Offers).
- 2.4 The quotation should hold good for any reduced or enhanced quantities without notice.
- 2.5 In the event of non-acceptance of offer, intimation may be given to the Tenders on their request.
- 2.6 Conditional offers or alternative offers are likely to be ignored.
- 2.7 Quotations should be based on FOB. The consignment will be shipped through Pakistan National Shipping Corporation (PNSC). In case there is no PNSC service in the country of shipping, please quote on C & F basis. The freight should be indicated separately. Insurance premium should not be included in the quoted price. However, where insurance is considered necessary, advice to that effect should be given in the quotation.
- 2.8 Submission of the offer through an agent in Pakistan should be avoided. In case it is considered inevitable, the agent's quotation must invariably be accompanied by the original proforma invoice from the principals/ manufacturers. **However, contract will be placed on principals / manufacturers.**
- 2.9 Country of origin and port of shipment to be stated.
- 2.10 The offer of principal must clearly indicate whether the rate quoted is inclusive of agent's commission, and if inclusive rate of commission included be specified.
- 2.11 Supplier will render necessary information regarding hazardous effects on environment, of the materials/products supplied by them, in their quotations and shipping/dispatch documents.
- 2.12 The Supplier will furnish a declaration regarding fees, commission and brokerage / environmental effect etc payable by the firm along with shipping documents.
- 2.13 If the requisite information is not furnished on the TE form or offer received is not in conformity with the requirement of the TE, the offer shall be ignored.

Contd...

3. **INSPECTION**

- 3.1 Pre-shipment inspection / acceptance of the machines at firm's premises will be carried out by 03 x POF officials for 02 x Weeks.
- 3.2 The supplier will provide Warranty / Guarantee Certificate of the machine, equipment & accessories which will be valid for a period of 24 x months after successful installation & commissioning of the machine.

4. **ACCEPTANCE OF OFFERS**

- 4.1 The procuring agency may reject all bids or proposals at any time prior to the acceptance of a bid or proposal. The procuring agency shall upon request communicate to any supplier or contractor who submitted a bid or proposal, the grounds for its rejection of all bids or proposals, but is not required to justify those grounds.
- 4.2 Procuring agency shall incur no liability, solely by virtue of its invoking sub-rule (1.1) towards suppliers or contractors who have submitted bids or proposals.
- 4.3 Notice of the rejection of all bids or proposals shall be given promptly to all suppliers or contractors that submitted bids or proposals.

5. **BID SECURITY**

- 5.1 A copy of bid security should accompany the tender in shape of deposit at call receipt / Pay order / Banker Cheque from schedule bank drawn in favour of **GM-Maint & SVS-AA (POF Wah Cantt)**.
- 5.2 Bid Security Instrument in original must accompany with the commercial offer as under:-
 - i. Registered / indexed firms including foreign firms – 2% of quoted value subject to max ceiling of Rs. 0.50 Mn.
 - ii. Registered / un-indexed firms including foreign firms – 3% of quoted value subject to max ceiling of Rs. 0.75 Mn.
 - iii. Un-registered firms including foreign firms – 5% of quoted value subject to max ceiling of Rs. 1.00 Mn.
 - iv. Government organization / production units / state owned enterprises / welfare projects of Svcs HQ – Rs. 50 Mn. can be waived off on request by DG(C).
 - v. Bid money will be returned to un successful (less first three lowest quote firms) bidders on opening of commercial offers.
 - vi. Bid money will be returned to successful bidder on submission of performance bond / unconditional BG.
 - vii. Quotation accompanied with less bid money will be accepted on provisional basis for 10 x days after opening of bids. However, the firms are bound to provide / furnish the balance bid money within 10 x days after opening of bid otherwise such quotations will be ignored or rejected.
 - viii. Offers received without bid security will not be entertained.
 - ix. Bid money will be forfeited in case the quotation is withdrawn before the expiry of its validity date.

Contd...

6. **PERFORMANCE BOND**

- (a) The successful bidder will provide Performance Bond at the rate of 10% of FOB value of the contract in favour of Controller of Military Accounts (CMA), Wah Cantt. The Performance Bond will be furnished in the form of Deposit At Call Receipt (CDR) from any scheduled Bank in Pakistan or an unconditional bank guarantee on prescribed Proforma covered by any schedule bank in Pakistan. The Performance Bond shall be furnished within 45 days from the date of opening of Letter of Credit. It shall be valid for a period of 24 months from the date of opening of letter of credit. The same will be got extended upto 24 x months after successful installation & commissioning of the machine accordingly. If the Performance Bond is not furnished within the above mentioned prescribed time, the Purchaser reserves the right to cancel the contract and make other arrangements for purchase of the machine at the risk and expense of the Supplier.
- (b) No Performance Bond will be required if the total FOB value of the contract is less than US \$ 50,000 and contract is placed directly on the foreign supplier.

7. **FAILURE TO SUPPLY THE STORES**

All deliveries must be completed by the specified date. If the failure to deliver the stores within the scheduled time should have a risen from "Force Majeure", which the Purchaser may admit as reasonable ground for further time, he will allow such additional time as he may consider to have been required by the circumstances of the case. Otherwise, he will be entitled, at his discretion, to cancel the contract; and/or, claim liquidated damages upto 2% but not less than 1% of the contract price of the items and their quantities for each and every month or part of a month, beyond the specified delivery date, during which these may not be delivered, subject to a maximum of 10% of the total contract value of particular store which remained unsupplied either in part or in full or, to purchase, from elsewhere, the unsupplied stores at the risk and cost of the Supplier.

8. **PAYMENT**

Payment to the supplier will be made through irrecoverable letter of credit with the following terms and conditions:-

- i. 70% payment will be released through LC against shipping documents including Acceptance Certificate signed by PSI team, confirming satisfactory pre-shipment inspection.
- ii. 30% payment will be paid through LC upon final acceptance subject to the following certifications signed by Inspection Team and MD-AA:-
 - a. Upon receipt of the machines in POF Wah Cantt along with all spares, tooling accessories, lubricant, software, manual standard / catalogue.
 - b. Successful installation & commissioning of machine at POF premises.
 - c. Successful production of 2000 x components each as per, Sketch-6A,6B, Sketch-7A,7B, Sketch-8A,8B & Sketch-9A,9B on each machine attached as Annexure "B".

All Bank charges incurred in Pakistan in connection with the establishment of LC will be borne by the Purchaser, whereas all Bank charges incurred in connection with drawing of payment including charges for confirmation of LC by the advising Bank/Foreign Bank will be borne by the Supplier.

Contd...

9. **ARBITRATION**

All matters of dispute or difference, except regarding rejection of stores by the inspector and / or cancellation of contract by the purchaser arising out of this agreement between the parties hereto, the settlement of which is not otherwise specially provided for in this agreement, shall be referred for adjudication to two arbitrators, one to be named by each party, who before entering upon the reference shall appoint an umpire by mutual agreements, and if they do not agree a judge of superior court shall appoint the umpire, the arbitration proceeding shall be held in Pakistan under the Pakistani law. The arbitration awards shall be un-spoken.

10. **SECURITY OF INFORMATION**

The tenderer and his employees must not communicate any information relating to the sale/purchase of stores under this enquiry to any person other than the manufacturer or to any press or agent not authorized in writing by POFs to receive it.

Please return the Schedule to the Tender duly signed by the specified date, along with the specifications drawings etc. if any, enclosed herewith - even if you are unable to quote.

WARNING

In case the firm abstain from making offers or fail to return/acknowledge the tender form by the specified date on three consecutive occasions, no further tender enquiry may be issued to them and their names would liable to be removed from the approved list.

NOTE:

Offers / bids through **Email & Fax** are not acceptable. The offers / bids must be submitted with warranty / guarantee certificate on firm's original letter head pad through **Mail / Courier**.

Yours faithfully,

(Munir Ahmad Naper)
Managing Director-AA

For and on behalf of the President
of Islamic Republic of Pakistan

PAKISTAN ORDNANCE FACTORIESSCHEDULE TO TENDER NO. 3521-2-2-54-FP-Capt-Pur-AA, dated 08-11-2024**(1) FOR PLANT AND MACHINERY**

(1)	(2)	(3)	(4)	(5)		(6)
Item No.	Description with Specs etc.	Unit	Qty.	Price Per Unit (FOB Value)		Delivery Date
				In Figures	In Words	
1	4-Axis CNC Milling Machine	No.	02			

- (2) Specifications: Enclosed as Annexure-'A'
 (3) Components Drawings: Enclosed as Annexure-'B'
 (4) Special Conditions: Enclosed as Annexure-'C'
 (5) Tech. Comparison: Enclosed as Annexure-'D'
 (6) Bid Qualification & Selection Criteria: Enclosed as Annexure-'E'

Note:- **SINGLE STAGE-TWO ENVELOPE PROCEDURE:**

- i. The bid shall comprise a single package containing two envelopes. Each envelope shall contain separately the technical and financial proposal.
- ii. The envelope shall be marked as "Technical Proposal" & "Financial Proposal" in bold and legible letters to avoid confusion.
- iii. Initially, only the envelope marked "Technical Proposal" shall be opened.
- iv. The envelope marked as "Financial Proposal" shall be retained in the custody of Bid Centre.
- v. During the technical evaluation, no amendments in the technical proposal shall be permitted.
- vi. The financial proposals of bids shall be opened publicly at a time, date and venue announced and communicated to the bidders in advance.

(5) UNDERTAKING:

Should our offer be accepted, we hereby undertake to supply the stores/render the services contracted on the basis of Conditions of Contract embodied in Form POF 1282, and to deposit the performance bond within the prescribed time, failing which it will constitute a breach of contract, and POF will have the right to purchase the stores/services elsewhere at our risk and cost.

Place _____
Date _____

Signature of Tenderer _____
Name _____
Position _____
Address _____
Income Tax G.I.R No. _____

Specifications

Nomenclature:

4-Axis CNC Milling Machine Qty 02 off

1. Main Features	
Work Piece Dimension	
Workpiece Dia	20 mm ~ 100 mm
Work piece Length	30 mm ~ 400 mm
Workpiece Material	Steel/Al/Al Alloy
Travel	
Longitudinal Travel (X-Axis)	1100~1200 mm
Cross Travel (Y-Axis)	400~520 mm
Vertical Travel (Z-Axis)	550~650
C-Axis	0 ~ 360°
Rapid feed rate for X-Axis, Y-Axis & Z-Axis	As per OEM's design
Main Spindle Speed	
Table Dimension	
No. of T Slots / Table Length & Width	As per OEM's design

ELECTRICAL SYSTEM	
i. Control System	Latest Fanuc/ Schneider/ Siemens or equivalent CNC Control including fault diagnostics and <ul style="list-style-type: none"> • Control must support at least 06 axis • Must have absolute measuring system • Lifetime software license with full feature access for CNC Control • Control must be closed loop • CAD / CAM solution & USB support to be provided • Remote fault diagnostic to be provided • Control must be dedicated CNC Control system • Communication software (Generic / Universal) • Battery Backup for CNC controller (if required)
ii-Electric Panel	Electrical panel with all required components with suitable air conditioning unit

<p>iii- Electric Supply & Safeties</p>	<p>Electrical panel with all required components with suitable air conditioning unit Electric supply system must confirm with following requirements</p> <ul style="list-style-type: none"> i. 400 ± 5% VAC, 50 Hz 3-Phase 4 wire system ii. 230 ± 5% VAC 50 Hz single Phase iii. The equipment / electrical panel should be properly earthed iv. Equipment should have stabilized power input, Line protection circuit breakers, thermal protection for motors. v. It should be followed by safety breakers to provide optimum selectivity vi. All motors should have IP 42 or better protection vii. System should be energy efficient with VFD control system. viii. The industrial electrical measuring instruments, wherever used and earthed, should have an accuracy of class <1 Ω or better. ix. Tropicalisation of Electrical Components & Motors x. In built Voltage Stabilization is required xi. Class F insulation should be provided <p>The acceptable specification will be those being governed by IEC recommendation. In addition to above, all other standard safeties may also be provided</p>
<p>iv- Technical requirement</p>	<ul style="list-style-type: none"> i. Automatic lubrication system ii. High pressure coolant supply in spindle and tool iii. Machine light iv. Automatic chip conveyor v. Electric hand wheel for manual feed and setup vi. Cooling attachment / arrangement for hydraulic, Unit, pump control cabinet

3. **SITE ENVIRONMENTAL AND OPERATING CONDITIONS**

- i. The ambient temperature variation between winter and summer is from -5°C to 50°C.
- ii. The relative humidity varies between 15 % to 80 % RH.
- iii. The high humidity period does not exceed 2 months in the years.
- iv. Earth quick value = 8.5 on Richter Scale (Normally)
- v. Available compressed Air Pressure 04 ~ 06 bar

4. **DOCUMENTS & LITERATURE**

Following documents are required: -

- | | |
|---|--------------|
| i. Operating manual in English language. | 04 Sets |
| ii. Trouble shooting manual in English language | 04 sets |
| iii. Schematic diagram of each PCB | 04 sets |
| iv. Main spindle Control Unit with diagram | 04 sets |
| v. Electric sequence control circuit of machine | 04 sets |
| vi. Details of motors and their control | 04 sets |
| vii. Operating maintenance and service manual in English. | 04 sets each |
| viii. Working drawing of tools & equipment. | 04 sets |
| ix. Programming manual | 04 sets |

5. **SAFETY**

- i. All equipment should be equipped/provided with all standard safety gadgets. Safety manual of machine may also be provided.
- ii. The machine should be environment friendly.
- iii. System should be safe to handle spikes and surges (Transient).

6. **APPLICATION STANDARDS**

- | | | |
|--------------------|-------------------------|-------------------|
| i. ISO 230-1-2012 | ii. ISO 230-2-2012/2014 | iii. VDI-DGQ 3441 |
| iv. ISO 230-5:2000 | v. ISO841:2001(E) | |

7. **TOOLING AND SPARES**

- i. The machine to be tooled up for manufacturing of following components:

Sr.	Description	Drawing No.	
1	Component-6	Sketch-6A,6B	Attached as Annexure – B
2	Component-7	Sketch-7A,7B	
3	Component-8	Sketch-8A,8B	
4	Component-9	Sketch-9A,9B	

- ii. Set of tool holders
- iii. Package cutting tools, equipment / accessories and tooling required for 02 years
- iv. Swiveling rotary table attachment as per components design
- v. Electrical, Electronics for control and mechanical spare parts for 02 Years
- vi. 1 x Laptop for each machine with preloaded licensed machine software and all types of back ups
- vii. 01 x Tool Kit for running & planned maintenance of machine

8. **OPERATION CYCLE TIME**

OEM will work out on machine cycle time for set of each component mentioned below for 2000 working hrs/annum:

Sr.	Description	Drawing No.	Capacity/Anum (Nos)	Time Cycle (sec)
1	Component-6	Sketch-6A,6B	7000	345
2	Component-7	Sketch-7A,7B	7000	270
3	Component-8	Sketch-8A,8B	7000	210
4	Component-9	Sketch-9A,9B	7000	195

9. **SETTING UP MACHINE:**

Machine tooled up and tried out for part as per Sketch-6A,6B, Sketch-7A,7B, Sketch 8A,8B & Sketch 9A,9B with fixtures / mandrel and tooling for 2 years. Turning and parting off tools with carbide inserts will be preferred.

10. **PRE-SHIPMENT INSPECTION AND TRAINING:**

- a. PSI of machines by 03 x POF officials for 02 x Weeks. Training of 06 x POF officials for 04 x Weeks on programming, operating and maintenance/troubleshooting of machine at OEM's premises. Boarding/Lodging, air tickets, travel, accommodations and daily allowance will be borne by the POF Wah Cantt.
- b. Free of cost on job training to POF officials will be provided by the OEM.
- c. During PSI, all Geometric protocol tests as per ISO/SI standards and motion diagram verification test of machine will be carried out.
- d. Inspection team besides others will particularly carry out trial run of machines and it will be considered satisfactory subject to the manufacturing of 100 Nos of each component according to drawings attached as Annexure "B" with zero rejection and as per defined time cycle.
- e. Provisioning of input materials for the manufacturing of component will be made by purchaser. However, dispatch of such materials from premises of purchaser to premises of manufacturer will be the responsibility of supplier
- f. The machine will be run for trial for 10 x days (at least 07 hours / day without break) to check abnormal noise, vibration & motors winding temperature.
- g. After manufacturing of components necessary inspection facilities will be provided by the supplier.
- h. Inspection of produced components will be carried out through gauges, SMEs and through enlargement where required. Arrangement of applicable gauges will be made by purchaser whereas arrangements for SMEs and enlargement will be made by supplier.
- i. The m/c will be dispatched only after the supplier receives the per-delivery trials acceptance certificate signed by controlling head i.e MD, issued by the purchaser certifying that the equipment has qualified the satisfactory working performance trial.
- j. The inspection team of POF officials will particularly carry out trial run of machine in the presence of supplier's rep.

11. **TECHNICAL SUPPORT:**

The Supplier shall confirm that after handing over of the m/c shall be technical support at least 15 years as & when required by the purchaser, in addition the purchaser shall be kept informed regarding latest advancement in the related technology for further improvement in the production and operation of the equipment.

12. **INSTALLATION, COMMISSIONING AND TRIAL PRODUCTION RUN:**

- i. The equipment/machines shall be installed by the purchaser under the supervision of the supplier's engineers and technicians.
- ii. The equipment/machines shall be commissioned and trial production of the equipment/machines shall be carried out by supplier's engineers. Purchaser shall provide required number of operators and technicians for the commissioning and trial production of the equipment/machines.
- iii. Requisite materials (Mechanical / Electrical) for installation & commissioning will be managed by the supplier.
- iv. Machine layout diagram will be provided by the firm well before shipment of machine to prepare civil structure (if required).
- v. The supplier is to indicate the total man-weeks of his engineers / technicians required for installation, commissioning and trial production of the equipment/machines. Terms and conditions are to be stated clearly. All expenses, including boarding & lodging, air travel and daily allowances of the engineers / technicians are to be borne by the supplier. Local transportation and pick drop from and to the airport shall be arranged by the purchaser.
- vi. The supplier is to indicate the time schedule for the completion of whole project.
- vii. The oil and process lubricants required 1st time for the equipment/machines for one year shall be supplied by the supplier.

13. **FINAL ACCEPTANCE TEST (F.A.T)**

- i. FAT of the machines will be conducted in the presence of purchaser technical team and supplier's rep.
- ii. Trial run of machine will be carried out to check abnormal noise, vibration, overheating, leakages & time cycle of the job to be machined.
- iii. Machine precision will be checked as per following criteria:

a. Positional uncertainty & repeatability test standard for linear Axis	VDI-DGQ 3441
b. Geometrical accuracy test	ISO 230-1-2012
c. Positional uncertainty for all linear axes for entire stroke	≤ 0.03 mm
d. Repeatability for all linear axes	≤ 0.02 mm
e. Accuracy of angular movement	≤ 25 arc sec as per standard ISO-230-2-2014

- iv. The machines will be tried out for capacity run and at least 2000 components of each as per drawing No. Sketch-6A,6B, Sketch-7A,7B, Sketch 8A,8B & Sketch-9A,9B will be produced on continuous run of machine. Material will be provided by purchaser. Inspection of produced components will be carried out through gauges, SMEs and through enlargement where required. Provisioning of applicable gauges will be made by purchaser.
- v. Rectification of produced components would not be allowed for qualification.
- vi. 100% inspection of produced components will be carried out. FAT will be considered "Acceptable / Satisfactory" only if machine produces components as per drawing with zero rejection and as per defined time.
- vii. Based on successful FAT report, a certificate will be issued by purchaser to supplier.
- viii. The supplier will provide free of cost on job training on the machine to POF officials at purchaser's premises during installation & commissioning.

14. **PAYMENT TERMS & CONDITIONS**

Negotiable payment terms through irrevocable L.C will be 70% against Shipping documents and 30% after satisfactory trial run / FAT of the machines at purchaser premises i.e. manufacturing components according to each drawing as per Annex "B".

15. **PERFORMANCE BOND.**

Performance Bond of 10% FOB value of the contract shall be provided by the supplier in the form of bank guarantee within 45 days from opening of LC. This shall remain valid for 24 months after the successful commissioning of trial run of the machine.

16. **WARRANTY / GUARANTEE**

- i. The supplier will provide Warranty / Guarantee certificate which shall be valid for a period of 02 years after signing of FAT (Final Acceptance test).
- ii. In case of damage to any part (Mechanical, Electrical, Electronics, Hydraulic & software etc.) supplier / firm will provide free of cost repair / replacement of all parts / accessories during warranty / guarantee period.

17. **DELIVERY SCHEDULE**

- i. Delivery of the machine will be made within 06 x months from placement of contract.
- ii. Delivery of the machine will be made on C&F basis.

18. **COUNTRY OF ORIGIN**

Europe, UK, USA, Japan, Turkiye & South Korea or any other country having license of machine manufacturing from these OEMs.

19. **MACHINE COLOR**

Green RAL 6011

MAJOR DIA = 42,000 MIN
 D₁ PITCH DIA = 41,350 + 0,170
 MINOR DIA = 40,917 + 0,236

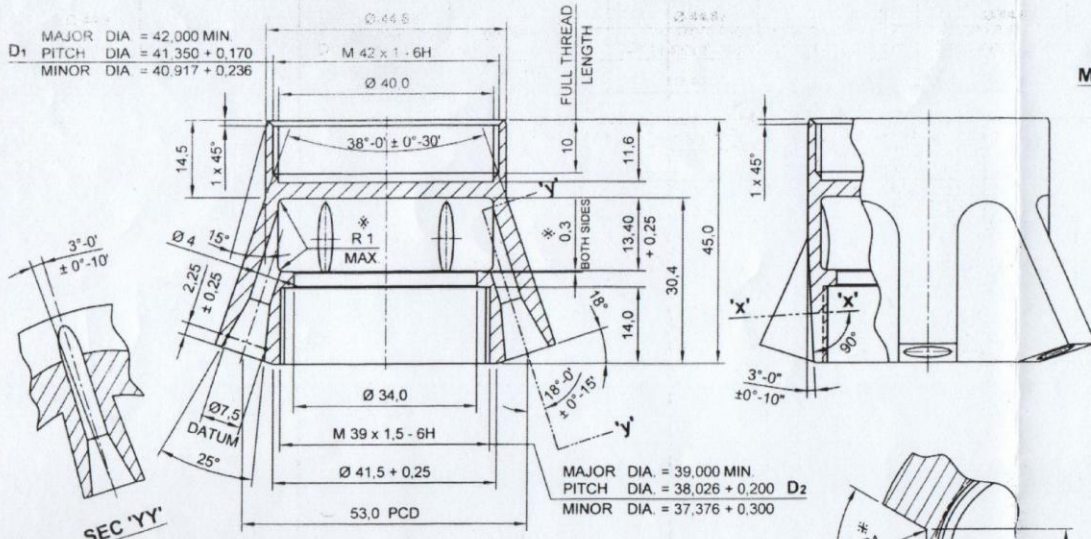

MATERIAL :-

"STEEL GRADE 50 Cr Mo4
 CONDITION G TO DIN 17200
 OR STEEL GRADE 50 Cr Mo4
 CONDITION +A TO
 DIN EN -10083-1"

MAJOR DIA = 39,000 MIN
 PITCH DIA = 38,026 + 0,200 D₂
 MINOR DIA = 37,376 + 0,300

SEC 'YY'

SECTION 'XX'

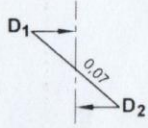
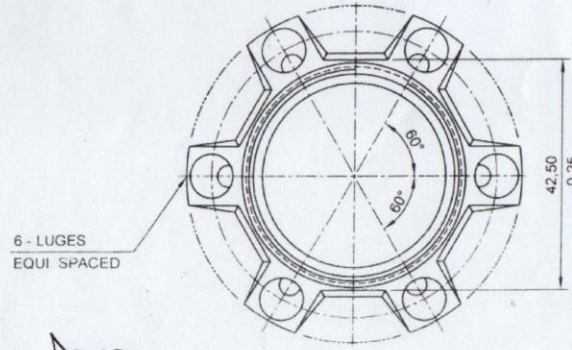

Aam

SKETCH - 6A

SKETCH - 6B

LUGS MILLING

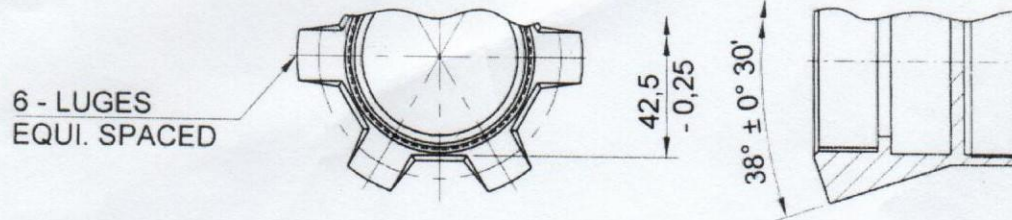

CENTRE DRILL LUGS

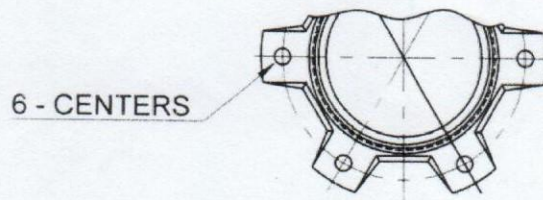

Δam5

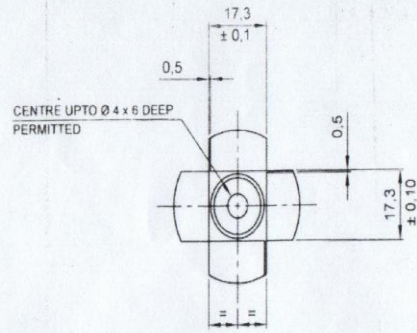

MATERIAL:-

ALUMINIUM ALLOY ASTM 8221 - 2014 A (T4) (T6)
OR B.S. 147, 2014 A (T4) (T6)

M 16 x 1.5 - 6g
 MAJOR DIA . 15,968 - 0,236
 PITCH DIA 14,994 - 0,140
 MINOR DIA. 14,128 - 0,248

DRILL SPOT UPTO Ø3
 MAX. PERMITTED

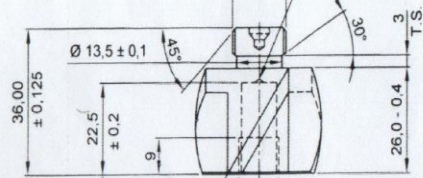

M 12 x 1 - 6H
 MAJOR DIA . 12,000 MIN.
 PITCH DIA 11,350 + 0,160
 MINOR DIA. 10,917 + 0,236

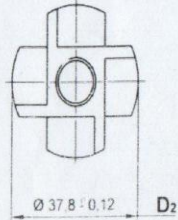
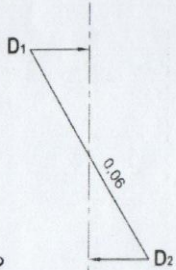

Aaw

SKETCH - 7A

SKETCH - 7B

MILLING OF 4 VANE

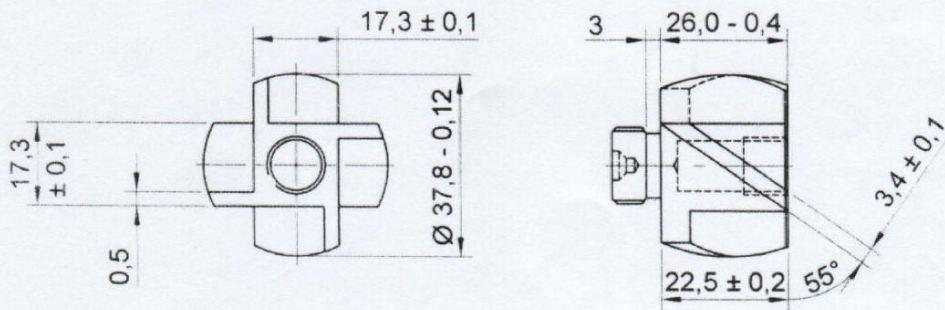

Aaus

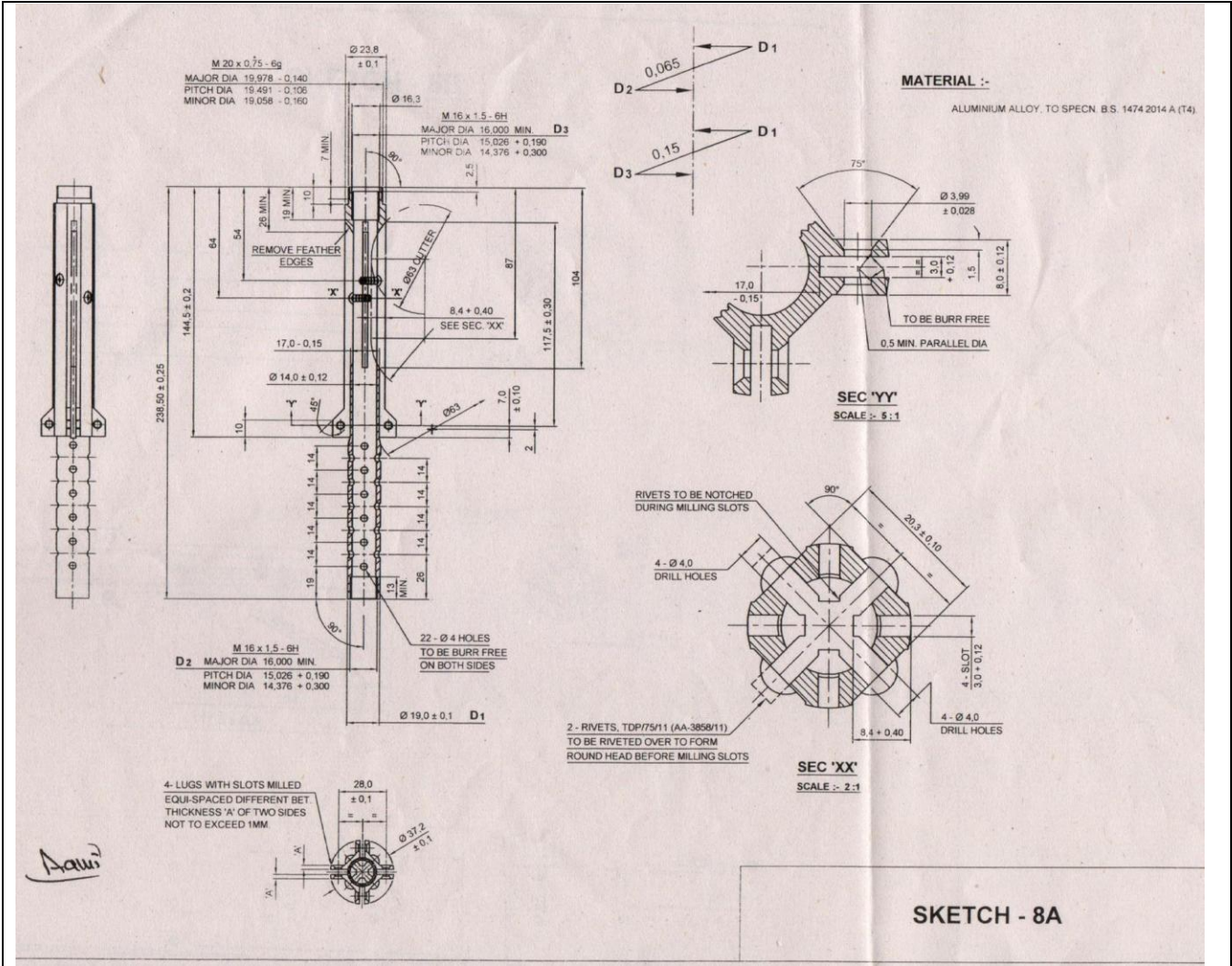

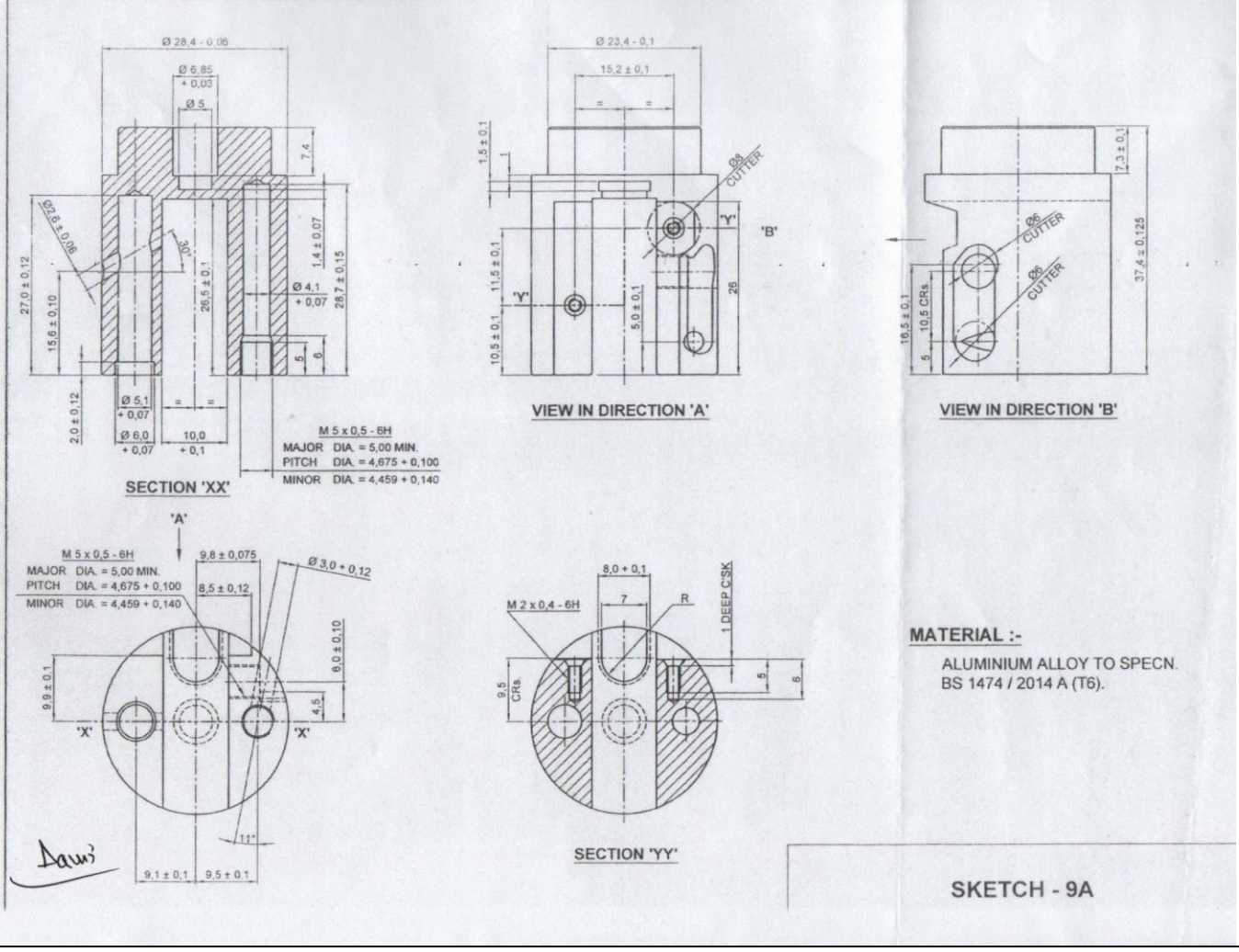

SKETCH - 9B

BEFORE MILLING OPERATION

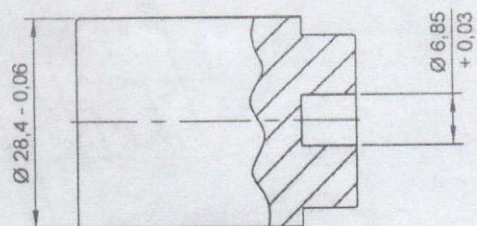

AFTER MILLING OPERATION

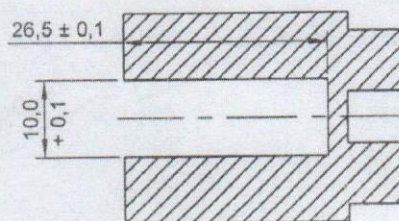

Daus

SPECIAL CONDITIONS

a) **TO BE FULFILLED AT THE TIME OF BIDDING / REPLY OF TENDER ENQUIRY**

- i. It may be confirmed that you will be able to obtain export license from your Govt. in the event of successful bidding.
- ii. OEM/authorized suppliers with company profile/brochure.
- iii. Performance of such type of machine supplied to various customer.
- iv. Backup service in Pakistan.
- v. Item wise price of machine, equipment & accessories alongwith Electrical, Electronic for control and Mechanical Spare Parts for 02 x years running maintenance should be quoted as part of commercial offer (Part-II). Essential maintenance & operational spares shall be supplied and ensure backup support for provisioning of spares for 10 years.
- vi. Reference Column 2.2 of Tender Enquiry Form No. 1262, any indication whatsoever of the price in Part-I of the quotation will render it invalid and void.
- vii. The supplier must fill in the Proforma of Technical Comparison enclosed as Annexure-'D' to the specifications and submit along with the technical offer for our instant evaluation.
- viii. The supplier will provide necessary brochures and technical literature alongwith Part-I of the offer (Technical Offer).
- ix. POF shall deal directly with the manufacturer / supplier of the machine. In case of manufacturer / supplier chooses to have a local agent, payment of agent's commission etc., shall be supplier's responsibility and shall not be included in the price quoted in Part-II of the offer (Commercial Quotation).

b) **CONDITIONS TO BE PART OF FORMAL CONTRACT AND MAY BE KEPT IN VIEW BEFORE BIDDING**

- i. 70% payment will be released on submission of shipping documents including Acceptance Certificate signed by PSI team, confirming satisfactory pre-shipment inspection.
- ii. 30% payment will be paid through LC upon final acceptance subject to the following certifications signed by Inspection Team and MD-AA:-
 - a. Upon receipt of the machines in POF Wah Cantt along with all spares, tooling accessories, lubricant, software, manual standard / catalogue.
 - b. Successful installation & commissioning of machine at POF premises.
 - c. Successful production of 2000 x components of each as per Sketch-6A,6B, Sketch-7A,7B, Sketch-8A,8B & Sketch-9A,9B on the machine.
- iii. The manufacturer / supplier will train at his premises 06 x POF officials for 04 x Weeks on programming, operating and maintenance/troubleshooting of machine at OEM's premises free of cost.
- iv. Pre-shipment inspection / acceptance of machines by 03 x POF officials for 02 x weeks at firm's premises will be conducted. The inspection team besides others will particularly carry out trial run of the machine and it will be considered acceptable subject to satisfactory production of 100 No of each component according to drawings attached as Annexure "B" with zero rejection and as per defined time cycle.
- v. Inspection of produced components will be carried out through gauges, SMEs and through enlargement where required. Arrangement of applicable gauges will be made by purchaser whereas arrangements for SMEs and enlargement will be made by supplier.

Contd...

- vi. Air tickets for both sides, boarding & lodging, inland transportation and provisioning of payment of Daily Allowance in respect of training & PSI teams will be borne by POF.
- vii. The manufacturer / supplier will ensure supply of foundation drawings and installation manual to the consignee at least two months before shipment of the machines.
- viii. The machines will be installed & commissioned at POF by the supplier’s Engineers. The machines will be run for trial and 2000 components of each as per. Sketch-6A,6B, Sketch-7A,7B, Sketch-8A,8B & Sketch-9A,9B will be produced on the machine. Material will be provided by POF. The inspection of produced components should be 100% acceptable.
- ix. The manufacturer/supplier will undertake regarding backup support for provisioning of Mechanical, Electrical & Electronic Spare Parts for 10 years maintenance after commissioning of the machines as and when required by POF. The undertaking shall be furnished by the firm in the shape of a certificate to be issued on the letter head of the firm alongwith the accepted copies of the contract (to be returned to the buyer).
- x. Four sets of document in English language operating manual, trouble shooting manual, Schematic diagram of each PCB, Main spindle Control Unit with diagram, Electric sequence control circuit of machine, Details of motors and their control, Operating maintenance and service manual in English, Working drawing of tools & equipment, Programming manual. These manuals must include comprehensive instructions regarding Operation and Maintenance containing detailed Electrical, Electronic, of the machine supplied.
- xi. The manufacturer/supplier will provide performance bond in the shape of Bank Guarantee @ 10% of net FOB (LC) value which will be valid for 24 x months after the date of expiry of letter of credit. The same will be got extended upto 24 x months after successful installation & commissioning of the machines accordingly.
- xii. The spare parts will be properly tagged with Part No. / Serial No. for identification.
- xiii. The machine must be packed in seaworthy packing and protected adequately & appropriately to the mode of dispatch against damages from water or other substances during sea voyage and over land journey to withstand the rough handling involved in transit and provide proper preservation of the machine while held in storage by the consignee.
- xiv. The machine must include complete tool kit for running & planned maintenance of the machine.
- xv. POF will hold no responsibility for any damage occurred during shipment of the machine.
- xvi. The supplier will provide on letter head duly signed and stamped declaration of fees, commissions & brokerage etc. along with the accepted copies of the contract.

Signature of the Supplier:

Name _____

Status in the Firm _____

Address _____

Place _____

Date _____

TECHNICAL COMPARISON
(TO BE FILLED BY SUPPLIER)

Sr. #	TENDER SPECIFICATIONS	OFFERED SPECIFICATIONS WITH REFERENCE TO PAGE NO. OF QUOTATION

BID QUALIFICATION & SELECTION CRITERIA

Sr #	Technical/Commercial aspects to be considered to ease out most advantageous bid	Compliance Level			Remarks
		Fully Complied	Partially Complied	Not Complied	
1*	Bid submitted in compliance with PPRA Rule 36(d)				
2*	Confirm to Tender Specification				
3*	Confirm Tender Quantity (s)				
4	Complete Technical literature/Brochure/catalogue provided in first go along with technical				
5.	Prices are valid for any reduced quantity(s) without notice				
6*	120 days bid validity from date of opening of commercial offers/bid confirmed				
7	Delivery period as per schedule of tender enquiry confirmed				
8	Payment terms as per tender enquiry				
9	In case of new entrant, proof of past performance/ list of identical supplies to prove capabilities in the relevant filed				
10*	Certificate regarding fulfillment of all tender requirements				
11*	T.E undertaking-Signed/Stamped				
12*	Offer/Bid (Tech+Comm) is un conditional				
13*	Complete company profile				
14	Certificate that firm is not blacklisted or under debarment by any Govt/Semi Govt Organization				
15.	Confirmation of performance Bond against LC as per T.E Clause-15				
16*	Main Features as per Annex "A" of T.E				
17*	Technical Requirements as per Annex "A" of T.E				
18*	Site & Operating Conditions as per Annex "A" of T.E				
19*	Country of Origin as per Annex "A" of T.E				
20*	Specification for Electric Supply System as per as per Annex-A				
21*	Literature Required as per Annex "A" of T.E				
22*	Additional Equipment as per Annex "A" of T.E				
23*	Terns & Conditions as per Annex "A" of T.E				
Note:- Clause with (*) are necessary to be complied. In case of non-compliance of the same, the bid may be disqualified					

Signature of the Tenderer with Stamp

Place-----

Date-----