



POF 1262-A
(INDIGENOUS
SUPPLIES)

Government of Pakistan
PAKISTAN ORDNANCE FACTORIES
TENDER ENQUIRY

To M/s

Dear Sirs,

Reference : TENDER ENQUIRY NO. 0007/LP/WPN/55

DATED 30-DEC-24

You are requested to submit quotations for the item(s) noted in the Schedule to the Tender. Please note the following instructions for filling the tender:-

1. SUBMISSION OF TENDER

- 1.1 Tenders will be opened at **11:00 hours** on **12-MAR-25** at Bid Centre adjacent to Rabita Hall, POF Wah Cantt. Quotation must be submitted electronically on www.ebidding.pof.gov.pk as well as in hard form (duly sealed in envelope) before 30 minutes of opening time. The tender received late will not be entertained. You may witness the opening of the tender if you so desire. If a representative is deputed, he should bring a letter of authority from you.

Tender Enquiry No: 0007/LP/WPN/55

Tender to be opened on: 12-MAR-25

Address as follows:-

(www.ebidding.pof.gov.pk) BID CENTER

ADJACENT TO RABITA HALL

POFs, WAH CANTT.

2. GENERAL INSTRUCTIONS REGARDING PREPARATION OF QUOTATIONS

- 2.1 **For Materials**, the prices should be filled in column 5 and delivery date in column 7 of the schedule to this Tender Enquiry. As per **PPRA Rule 36(b)**, **Single Stage two envelope method** will be utilized for "Open competitive bidding." Moreover, technical & commercial evaluation of Bids will be carried out strictly as per PPRA rules and contract(s) will be awarded to the most advantageous bidder(s).

- 2.2 **For Plant and Machinery**, you are required to quote in two parts:-

Part I "Technical Offer": It should exclusively give technical details and literatures/brochures of the offered plant, machinery and equipment; validity date; delivery schedule; and signed undertaking given on the schedule to this Tender Enquiry. It must not indicate price, costs etc.

Cont....P-2

Part II "Commercial Offer": It should indicate the commercial terms e.g. price, terms of payment, mode of payment, mode of supply.

- 2.3 The quotation must remain valid for, at least 90 days from the date of opening of commercial tenders, extendable if so desired.
- 2.4 The quotation should hold good for any reduced or enhanced quantities without notice.
- 2.5 In the event of non-acceptance of offer, intimation may be given to the Tenderers on their request.
- 2.6 Conditional offers or alternative offers are likely to be ignored.
- 2.7 Quotations should be based on:-

F.O.R. station of dispatch basis, i.e. delivered free on rail, inclusive of packing and forwarding charges. The stores will be booked under Military Credit Note, to be provided by the purchaser.

and/or

Free delivery at POF's stores at **WAH CANTT**
In this case Octroi duty, will be payable by the supplier.

- 2.8 Taxes and Duties etc. where applicable, must be shown separately, quoting references to Registration No. in cases of Sales Tax and relevant authority in the case of others. Offers without these clarifications and inclusive of Taxes and Duties may be ignored.
- 2.9 Taxes and duties levied on or after Tender opening date or on or after the date offer was signed and dispatched will be allowed to include in the offered rates.
- 2.10 "Suppliers will furnish a certificate, issued by Excise & Taxation deptt., that he has cleared all Professional Tax payable by him" offers received without this certificate will be rejected.
- 2.11 Suppliers will render necessary information regarding hazardous effects on environment, of the material/products supplied by them, in their quotations and shipping/dispatch documents.
- 2.12 If the requisite information is not furnished on the T.E forms or offer received is not conformity with the requirement of the T.E such offer shall be ignored.

3. INSPECTION

- 3.1 Supplies shall be subject to the inspection and acceptance by the competent inspection authority nominated by the Purchaser, who will arrange it at his own cost. Inspection facilities such as tools, test equipment, instruments etc will, however, be provided by the Suppliers in accordance with the relevant specifications.
- 3.2 Where considered necessary by the Purchaser, stores may be obtained on Warranty/Guarantee subject to inspection on receipt. Rejected stores will be removed and replaced with the acceptable stores by the Supplier at his own expense, within a specified time.

4. TENDER FEE

The tender must be accompanied by a copy of non-refundable fee by means of a crossed postal order/pay order for Rs. 500/- in favour of: **Director-Admin-POFs, Wah Cantt.** The tender fee instrument in original must be provided on day/date of tender opening in the Bid Center.

4.1 TENDER SAMPLE

Where required, offer must accompany tender sample., strictly according to the description and specification given in Tender Enquiry. Offer not accompanied by tender sample will NOT be entertained excepting the established and reputable firms who have either previously satisfactorily supplied the same or similar stores or have submitted an acceptable sample thereof against previous T.E.

5. BID Security

5.1 A copy of Bid Security should accompany the tender in shape of deposit at call receipt/Pay Order/Banker Cheque from scheduled bank drawn in favour of :-

GM-PPC-WPNS

5.2 Bid security instrument in original must be provided on the day/date of tender opening in the Bid Center as under:

- a. Registered/indexed firms including foreign firms - 2% of quoted value subject to the maximum ceiling of Rs. 0.5 Mn.
- b. Registered/un-indexed firms including foreign firms - 3% of quoted value subject to the maximum ceiling of Rs. 0.75 Mn.
- c. Unregistered Firms including foreign firms - 5% of quoted value subject to the maximum ceiling of Rs. 1.00 Mn.
- d. Govt organization/production units/state owned enterprises/welfare projects of Svcs HQ - Rs 0.50 M. can be waived off on request by DG(C)
- e. Bid money will be returned to unsuccessful (less first three lowest quotee firms) bidders on opening of commercial offers
- f. Bid money will be returned to successful bidders on submission of performance bond/unconditional B.G.
- g. Quotation accompanied with less bid money will be accepted on provisional basis for 10 x days after opening of bids. However the firms are bound to provide/furnish the balance bid money within 10 x days after opening of bid otherwise such quotations will be ignored or rejected
- h. Offers received without Bid Security will not be entertained.
- i. Bid money will be forfeited in case the quotation is withdrawn before the expiry of its validity date.

6. ACCEPTANCE OF OFFERS

6.1 POF may reject all bids or proposals at any time prior to the acceptance of bid(s) or proposal, but is not required to justify grounds for its rejection. POF shall incur no liability towards supplier or contractor who have submitted bids or proposals.

6.2 PERFORMANCE BOND

- (a) The successful bidders shall provide performance bond which shall not exceed 10% of contract value, in the form of Deposit At Call Receipt from a scheduled Bank; or, an un-conditional Bank Guarantee on a prescribed format. The performance Bond will be in favour of C.M.A.(POF) Wah Cantt. It will be returned on satisfactory completion of contract.
- (b) If the Supplier fails to furnish the Performance Bond within the specified time, such failure will constitute a breach of the contract and the Purchaser shall be entitled to make other arrangements for purchase of the stores at the risk and expense of the Supplier.

6.3 Performance Bond from State owned organizations may be waived off at the discretion of the Purchaser.

6.4 **FAILURE TO SUPPLY THE STORES**

All deliveries must be completed by the specified date. In case of failure to deliver the stores within the scheduled time should have arisen from "Force Majeure", which the purchaser may admit as reasonable ground for further time, he will allow such additional time as he may consider to have been required by the circumstances of the case. Otherwise, he will be entitled, at his discretion, to cancel the contract; and/or claim liquidated damages upto 2% but not less than 1% of the contract price of the items and their quantities for each and every month or part of a month, beyond the specified delivery date, during which these may not be delivered, subject to a maximum of 10% of the total contract value of the particular stores which remained unsupplied either in part or in full; or, to purchase from elsewhere, the unsupplied stores at the risk and cost of the supplier.

6.5 **PAYMENT**

Payment will be made by the CMA(POF) through crossed cheque on receipt/acceptance of stores on our prescribed bill form supported by receipt voucher on part/full supply basis.

(a) Payment of duties/Taxes including professional tax (where applicable) must be supported by proof of having paid these to concerned Govt. Taxation Deptt.

7. **SECURITY OF INFORMATION**

The tenderer and his employees must not communicate any information relating to the sale/purchase of stores under this enquiry to any person other than the manufacturer or to any press or agent not authorised in writing by POFs to receive it.

Please return the Schedule to the Tender duly signed by the specified date, along with the specifications, drawings etc. if any, enclosed herewith - even if you are unable to quote.

WARNING In case the firm abstain from making offers or fail to return/acknowledge the tender form by the specified date on three consecutive occasions, no further tender enquiry may be issued to them and their names would be liable to be removed from the approved list.

Yours faithfully

ABDUL SATTAR BALOCH
GM-PPC (W)

for PAKISTAN ORDNANCE FACTORIES

PAKISTAN ORDNANCE FACTORIES

SCHEDULE TO TENDER NO. 0007/LP/WPN/5530-DEC-24(1) FOR MATERIALS

(1)	(2)	(3)	(4)	(5)	(6)		(7)
Item No.	Description with Specs. etc.	Unit	Qty	Quoted Value	Price Per Unit FOR or free delivery		Delivery Date
					In Figures	In Words	

1	MULTY PURPOSE CARRYING SLING R3/3 FOR SMALL ARM 100407-3-800	NO	8490				IMMEDIATE
2	CLEANING KIT (COMPLETE SET) DRG.NO.100200	SET	13360				IMMEDIATE

Total Rs =	
+ GST =	
Total value Rs =	

(2) For Plant & Machinery:
Specification:-

(3) **Special Conditions**

- 01 Recovery of Stamp Duty amounting to 0.25% of total contract value is liable to be recovered from the contractors.
- 02 The provision of ATL, PTC and NTN is mandatory along with offers by the supplier.
- 03 GST as per rule will be applicable.
- 04 Delivery period will be 30 x days after issuance of contract.
- 05 POFs Management reserves the right to discourage the offers of supplier with poor/unsatisfactory performance (sub-standard/delayed supplies) against previously awarded contracts.
- 06 Provision of sample is mandatory along with technical offer/s or within 07x days after technical opening. otherwise, your offer will be rejected.
- 07 Inspection Authority: Rep of MD-Weapons.
- 08 Offers received with multiples rates will not be entertained
- 09 As per P.P.R.A. Rule (Two Envelop) Kindly send Technical and Commercial quotation separately, Technical quotation will be opened on due date.

PAKISTAN ORDNANCE FACTORIES

SCHEDULE TO TENDER NO. 0007/LP/WPN/55

30-DEC-24

(1)	(2)	(3)	(4)	(5)	(6)		(7)
Item No.	Description with Specs. etc.	Unit	Qty	Quoted Value	Price Per Unit FOR or free delivery		Delivery Date
					In Figures	In Words	

Undertaking

Should our offer be accepted, we hereby undertake to supply the stores/render the services contracted on the basis of General Conditions of Contract embodied in Form POF 1281, and to deposit the performance bond within the prescribed time, failing which it will constitute a breach of contract, and POF will have the right to purchase the stores/services elsewhere at our risk and cost.

Place _____
 Date _____

Signature of the Tenderer _____
 Name _____
 Position _____
 Address _____
 Income Tax G.I.R. No _____
 Official Stamp _____

PRO
ISSUED
A.M. P.M. QTY. S.I.
SIG. [Signature] DTG: 11-2

Ansicht ohne Pos. 7

Größe: 150 x 100 mm
Material: Kunststoff

CLEANING EQUIPMENT CONSIST OF:

sr	qty	Nomenclature	Drawing No.
1	1-	Container	(100 287) AW-610 PD
2	1-	Oil Brush	(100 202) AW-595 PD
3	1-	Wire Brush	100 201
4	1-	Chain for cleaning Brush	SK/E-4179 (100 285)
5	1-	Oil container	-
6	1-	Brush	79002
7	3-	Cleaning Wick (Pull through)	VTL 1090.001

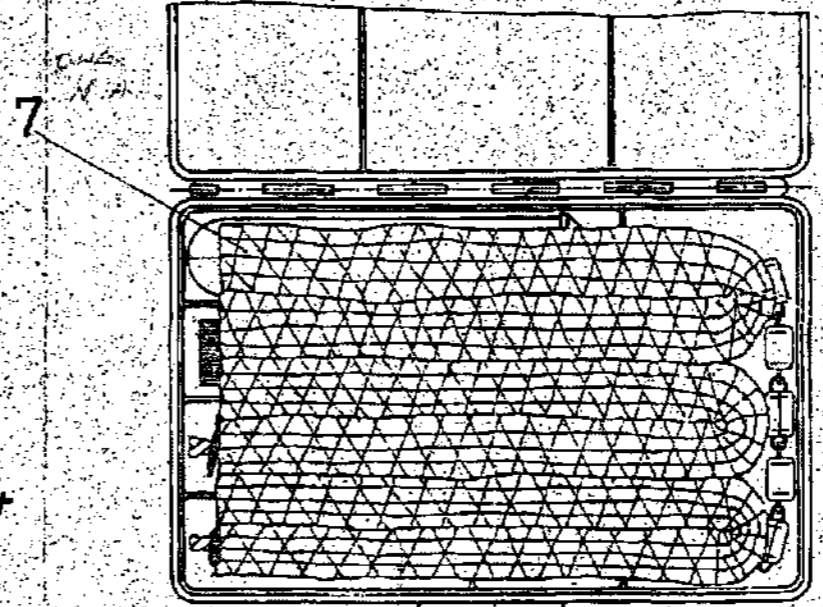
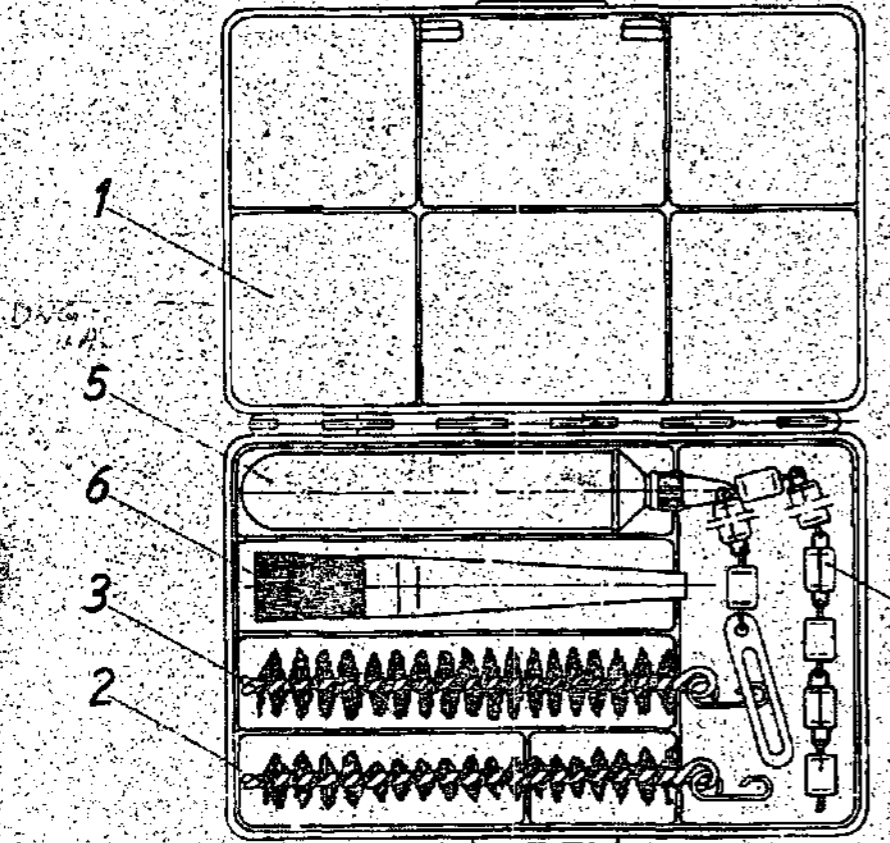

1. 2. 3. 4. 5. 6. 7.

28.12.67
28.12.67

Art. Nr.	Art. Bezeichnung	Fig.	Menge	Ident. Nr.	Maßstab
				211 023	
	Reinigungsgerät, Waffen, Kal. 7,62-9mm				1:1
	100200 Weapon Cleaner				

ENGINEER USED ON
 100-500 PD

SEALED

AMENDMENTS		
DATE	INITIALS	NATURE
06-17	HW-2848	SCALED
08-12	HW-3161	PARTS SPE. CORR. & REVISIONS MADE.

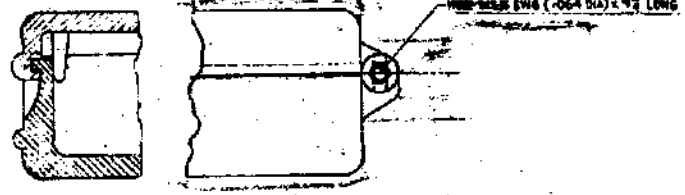
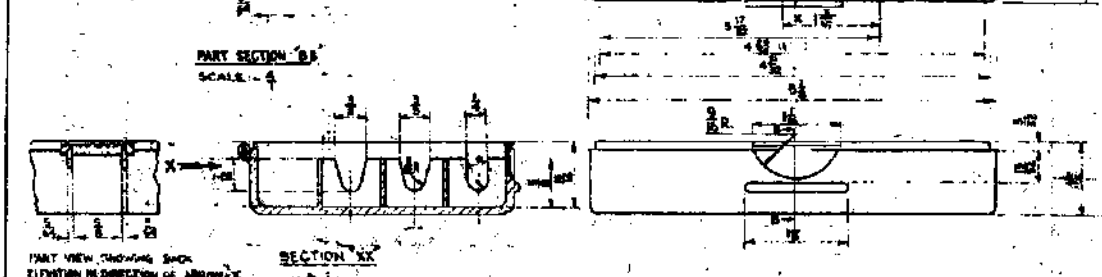
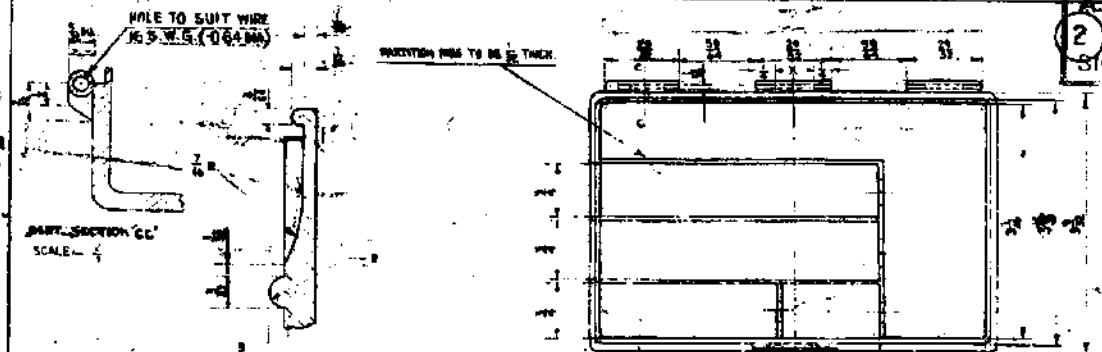
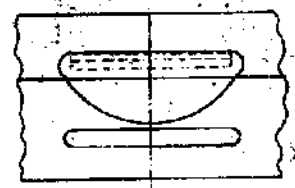
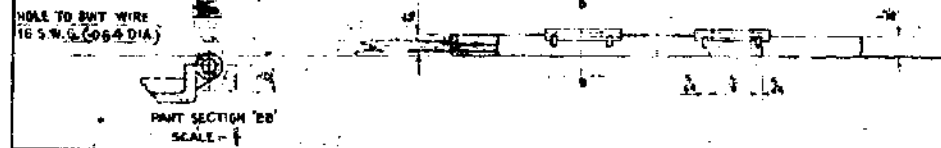
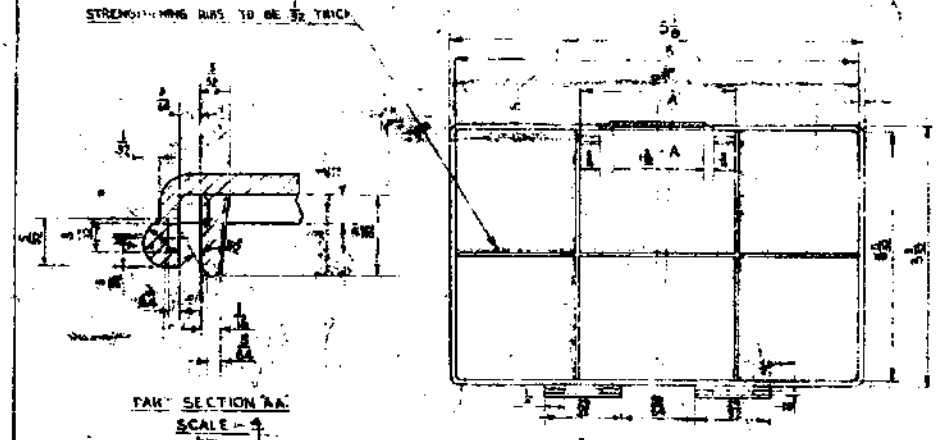
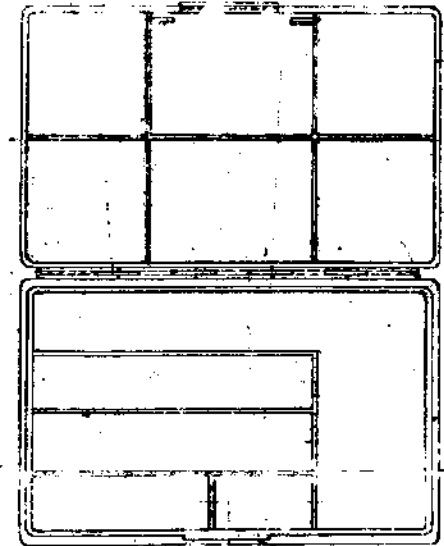

VIEW IN DIRECTION OF ARROW 'X'
 WITH LID CLOSED SHOWING WIRING ARRANGEMENT
 SCALE - NOT TO SCALE

2
 816
 P.C. DIV. 01
 DTG 31402

CONTAINER, CLEANING KIT RIFLE, EMPTY, G-3.

ALSI FOR MG 1A3.

FOR SPECIFICATION OF DIMENSIONS, ETC., SEE P.A.D. NOTE WEST 28.1
 THIRD ANGLE PROJECTION
 DIMENSIONS ARE IN INCHES
 UNLESS OTHERWISE NOTED
 DRAWN BY: [Signature]
 CHECKED BY: [Signature]
 DATE: 10-1-55

1005-ZO-10-664

ALL DIMENSIONS IN mm. FIRST ANGLE PROJECTION METHOD USED.
 GAUGING DIMENSIONS MARKED @ GAUGING SURFACES HARDENED WHERE POSSIBLE.
 INFORMATION MARKED * TO BE MARKED ON GROUND ▽▽▽ LAPPED ▽▽▽ POLISHED ▽▽▽
 MACHINED WHERE SHOWN ▽ DIMENSIONS MARKED * ARE IMPORTANT;
 UNTOLERANCED DIMENSIONS TO BE WITHIN UP TO 6 ± 0.1, 6 TO 30 ± 0.2, 30 TO 100 ± 0.3.

DET. NO.	NO. OFF.	DESCRIPTION	MATERIAL	STOCK SIZE	H. TREATMENT.
----------	----------	-------------	----------	------------	---------------

A PIECE OF ROPE LENGTH 150 to 155mm WITH 12 to 16 STRAND WOVEN BY 0.2mm STRINGS AND THE DIA OF THE CLEANING WICK SHOULD BE 10 to 12mm. WEIGHT = 3 grams

MATERIAL:-

- i-CLEANING WICK IS MADE OF COTTON BLEND
- ii-STRING IS MADE OF COTTON TWINE

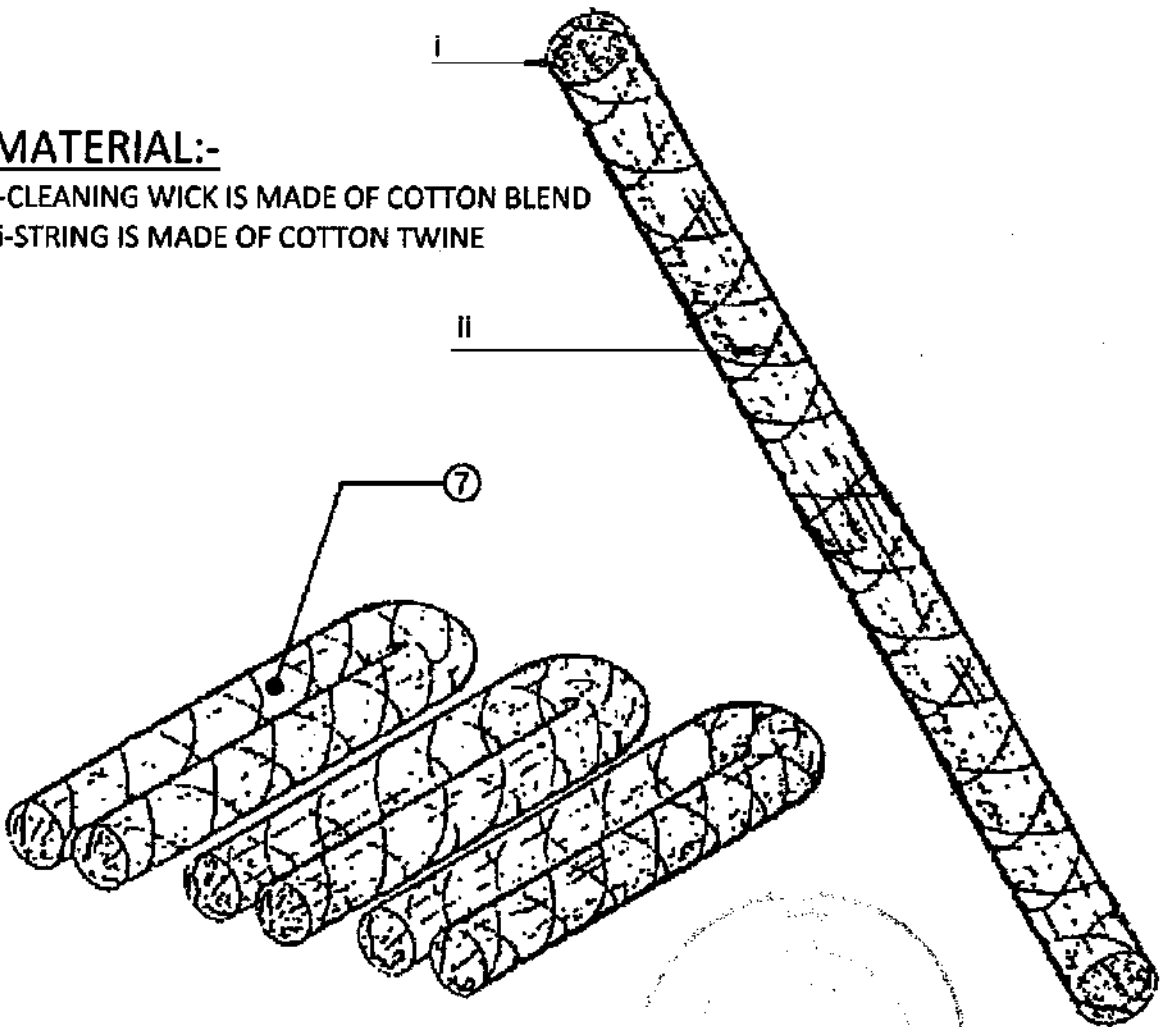

IF IN DOUBT ASK!

PROVISIONAL

		REL. P.D.O. ISSUED AM PUR SIG. S DT. 03.12.21		DRAWN:- M.HANIF	
				CHECKED:- <i>[Signature]</i>	
				EXAMINED:-	
				APPROVED:- <i>[Signature]</i>	
				SCALE:- 1:1	
DATE	MOD. NO.	AMENDMENTS	SIGR.	BASED ON SAMPLE	
CLEANING WICK FOR CLEANING KIT				P.O.F.(W)	
cal. 7.62 - 9 mm				SK/E - 6417	
RIFLE: G3A3, MG3, MP5				DATE:- 21 - 01 - 2019	

Reference: Brochure of MG3 (List of spare parts and accessories Page No. 168)

IF IN DOUBT ASK!

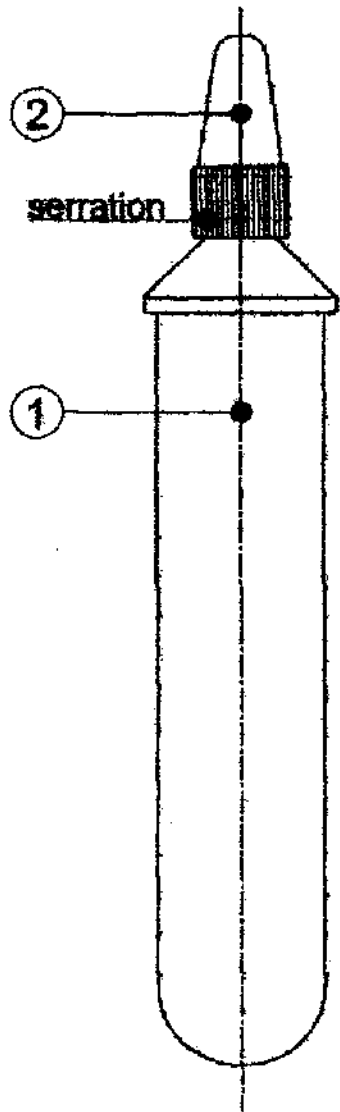

Ø6,8 SINGLE START
KNUCKLE THREAD P=1

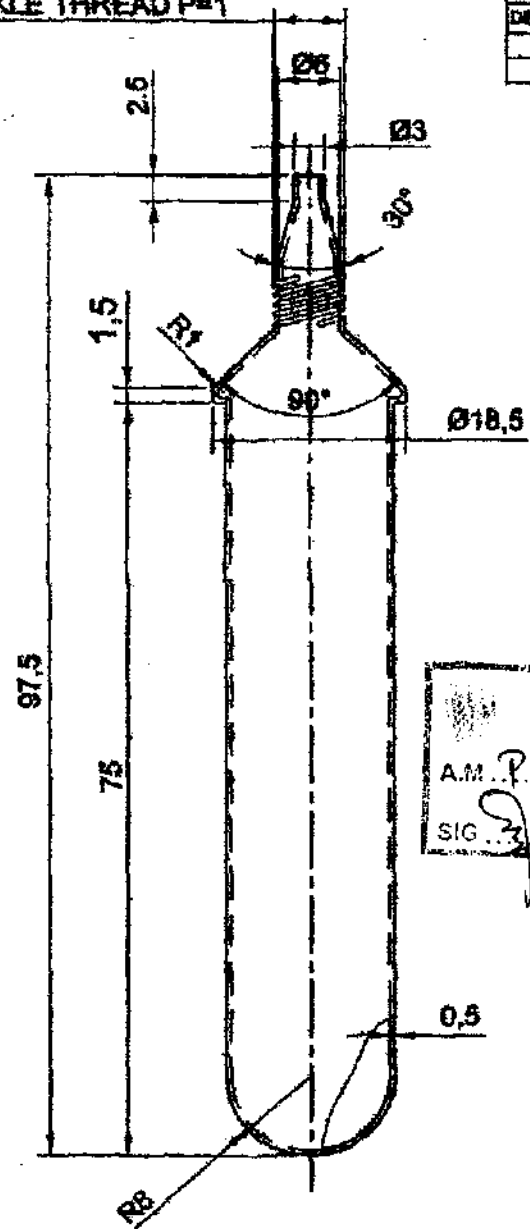

ALL DIMENSIONS IN mm. FIRST ANGLE PROJECTION METHOD USED.
GAUGING DIMENSIONS MARKED ⊕ GAUGING SURFACES HARDENED WHERE POSSIBLE.
INFORMATION MARKED ⊕ TO BE MARKED ON √√√ GROUND √√√ LAPPED √√√ POLISHED.
MACHINED WHERE SHOWN √√ DIMENSIONS MARKED X ARE IMPORTANT.
UNTOLERANCED DIMENSIONS TO BE WITHIN UP TO 6mm.1, 6 TO 30mm.2, 30 TO 100mm.3.

DET NO.	NO. OFF.	DESCRIPTION	MATERIAL	STOCK SIZE	H.TREATMENT
1	1	OIL BOTTLE	*	-	-
2	1	CAP FOR BOTTLE	**	-	-

- * HDPE (High Density polyEthylene or LDPE (Low Density PolyEthylene).
- ** DIN-18, Plastic type 'PP'.

2

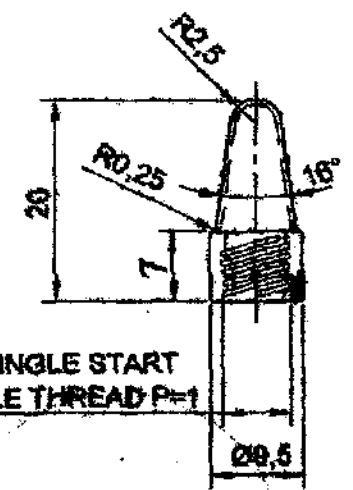

PDO
ISSUED
A.M. P.H.R. ...
SIG. ... DT. 03.12.24

Ø6,8 SINGLE START
KNUCKLE THREAD P=1

PROVISIONAL

DATE	MO. NO.	AMENDMENTS	SIGN.

DRAWN:- ASADULLAH
CHECKED:-
EXAMINED:-
APP'D:-
SCALE:- 1:1

BASED ON
SAMPLE
P.O.P (M)

OIL CONTAINER FOR CLEANING KIT (100200)
CAL 7.62 - 9mm
RIFLE: G3AS, MG3, MP5.

SK/E-6418
DATE- 21-01-2019

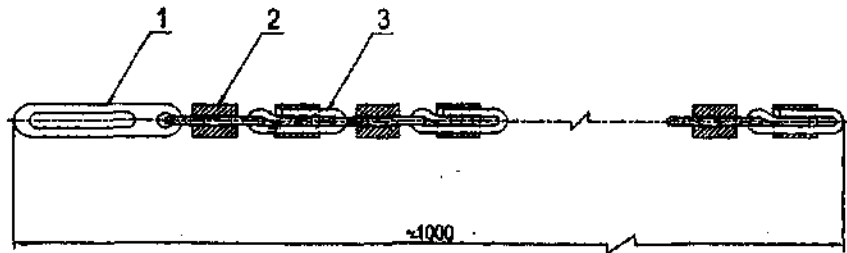

SCALE = 1:1

ALL DIMENSIONS IN mm. FIRST ANGLE PROJECTION METHOD USED.
 GAUGING DIMENSIONS MARKED ⊕ GAUGING SURFACES HARDENED WHERE POSSIBLE.
 INFORMATION MARKED * TO BE MARKED ON ∇∇∇ GROUND. ∇∇∇ LAPPED. ∇∇∇ POLISHED.
 MACHINED WHERE SHOWN ∇∇ DIMENSIONS MARKED × ARE IMPORTANT;
 UNTOLERANCED DIMENSIONS TO BE WITHIN UP TO 8±0.1, 8 TO 30±0.2, 30 TO 100±0.3.

DET. NO.	NO. OFF	DESCRIPTION	MATERIAL	STOCK SIZE	H. TREATMENT.
1	1	HOOK	* C 15	35 x 8 x 1.8 Thick	CASE HARD
2	58	BUSH	* ALUMINIUM	Ø8 x 10	—
3	88	LINK	* SPRING STEEL WIRE	Ø 1.5	HD & TD

IF IN DOUBT ASK!

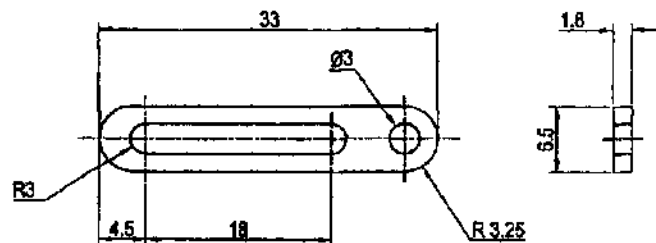

MATERIAL: C 15
 * PHOSPHATED, (Mn phr 20%)
 THICK. OF LAYER 0.1 mm APPROX.
 DIN - 50942
 SHARP EDGES TO BE REMOVED.

①

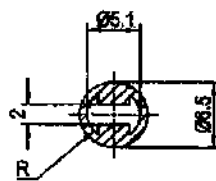
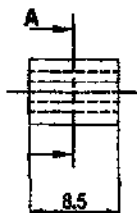

MATERIAL: ALUMINIUM
 * EN AW - 6060 EN AW-AL MgSi
 TO DIN - 573 - 3
 SHARP EDGES TO BE REMOVED.

②

PDO
 ISSUED
 A.M. PUR. QTY. 01
 SIG. BTG: 12.26

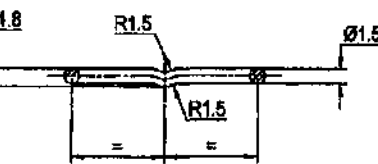
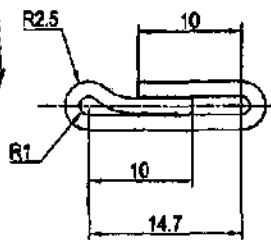

MATERIAL: SPRING STEEL WIRE, DIN 17223 P1-1 GRADE'D
 * PHOSPHATED, (Mn phr 20%)
 THK. OF LAYER 0.1 mm APPROX.
 DIN - 50942

③

DATE	MOD. NO.	AMENDMENTS	SIGR.

DRAWN:- IMTIAZ
 CHECKED:-
 EXAMINED:-
 APPVD:-
 SCALE:- 2:1
 BASED ON
 SAMPLE
 P.O.F.(W)

CHAIN FOR CLEANING BRUSH
 MG3 , G3A3 & MP5A2

SK / E - 4179

DATE:- 04-04-2019

DIN 17 31.08.54
J. Müller

Certified Correct Copy of Scale
 Drawing of this Date 03-01-92
Handwritten signature F/A
 2

WT

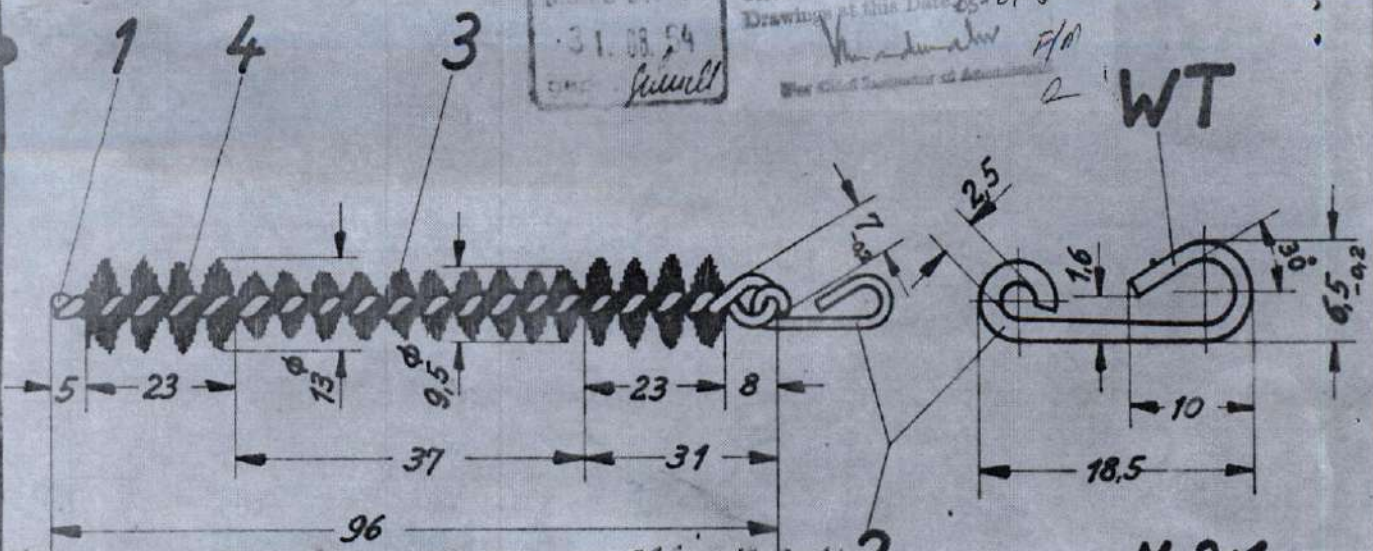

ROHM-AMENDED & PEN-AMENDED AW-3992 16-2-61
 NOMIN AMENDED AW-3855-78-10-79
 B2/1005-70-100-6785
 M 2:1

Maße ohne Toleranzangabe nach		mittel		DIN 7168		Brush, pile 7-62 mm		SCALE	
Baub.		Tag		Name		CLEANING BRUSH		Maßstab	
9.7.64		9.7.64		Saler		Reinigungsbürste		1:1	
Gepr.		Gepr.		Gepr.		Brush pile for cleaning small areas		2:1	
Norm.		Norm.		Norm.		BRUSH PILE FOR CLEANING SMALL AREAS		2:1	
Sealed AW-3808 31.5-79		BWB-WMI 1		16mm		DIAPHOSPHOR BRONZE WIRE No 36 SWG		100201	
And-zust.		And-Mittlg.		Tag		Name		1005-20-100-6785	
								Nr.	

1. Lfd. Nr.	2. Stückzahl	3. Name Benennung	4. Sach-Nr. Index	5. DIN A	6. Bemerkungen Remarks
		zinc plated steel wire 2 DIN 177, 250 Lg			
1	1	Stahldraht 2 DIN 177 verzinkt ≈ 250 Lg	100 201 - 00.01	-	
2	1	Hook Draht 1/4 A DIN 2076 - A ≈ 38 Lg Bristles	100 201 - 00.02	-	WT
3		Borsten 0,2 φ Sn Bz 6 F 36 DIN 17662	100 201 - 00.03	-	Quantity according to order Menge n. Bedarf
4		Borsten, falbe (s. VTL) Bristles	100 201 - 00.04	-	Quantity according to order Menge n. Bedarf
Spring steel wire φ 1.4A DIN-17223 Pt.1 grade D			Ref.No. 0501/Vol.-80 Dated: -25-7-95		
DC (P) AW 4606 DT:04-9.95					

P.D.O. ISSUED
 AM. PUR. QTY. 01.

NON AMENDED AW-3992		1964 Tag		Name		Cleaning Brush		Liste best. aus 1. Blatt	
AND PEN-AMENDED 16-2-61		Baub. 9.7.		Saler		Reinigungsbürste		Blatt Nr. 1.	
NOMIN AMENDED AW-3855		Gepr.		Gepr.		Brush cleaning small areas 10 mm DIA		Blatt Nr. 1.	
AMENDED 78-10-79		Norm		Norm		Phosphor Bronze wire No 36 SWG		Vervielf. Pause	
Sealed AW-3808 31.5-79		BWB - WM I 1				ST 100 201 B2/1005-20-100-6785		5	
And-zust.		And-Mittlg.		Tag		Name		Nr.	

USED ON
AW-594-A

3



Approved for the design/working drawings of this part by the Chief Inspector of the Army Ordnance Corps, Bangalore.

Certified Correct Copy of Scales
Drawings of this Date: 62-7-82
For Chief Inspector of A...

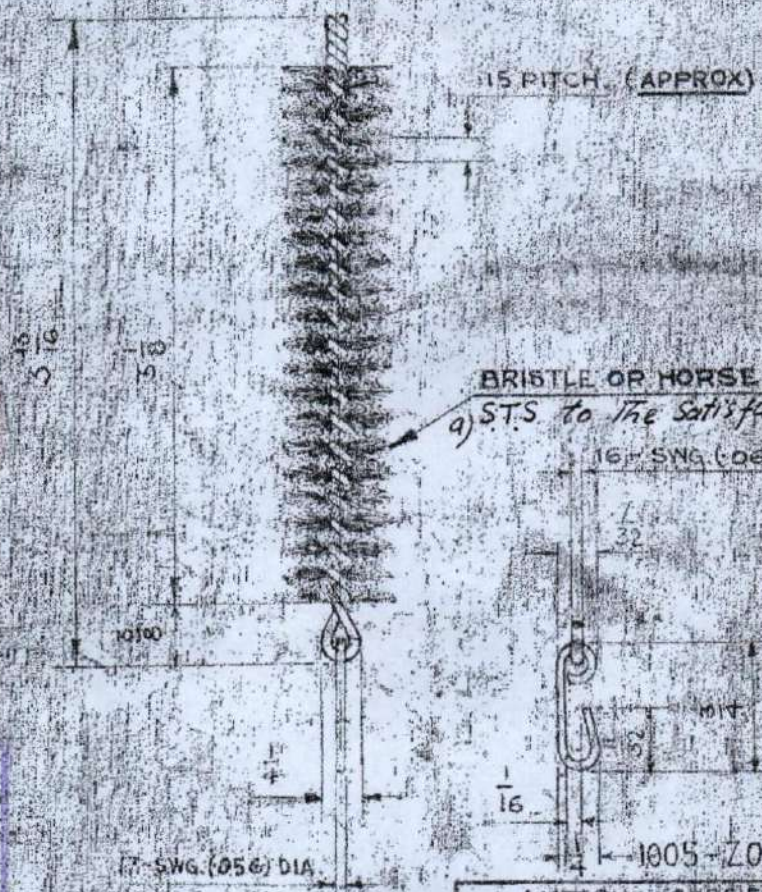

BRISTLE OR HORSE HAIR,
9) S.T.S. to the satisfaction of I.O.
16 SWG. (.064) DIA.

DCPAG USAG/10-10-90

APPROVED
A.M. [Signature]
SIG [Signature]

MATERIAL SPECIFICATION		
DESCRIPTIONS	QUANTITY	WEIGHT
MILD STEEL WIRE GALVANISED.		

DRG. NO
AW-595-PD.

PART NO
PSM 307

NOMN. AMENDED AND P.T. NO ADDED	AW-4010	26-3-61
DETAIL, ALSO FOR IUG 1A3 ADDED.	AW-2645	19-5-69
MATERIAL AMENDED	AW-2818	5-5-68
HT. WIRE NO. 10 SWG AMENDED TO REPLACEMENT STANDARD TRADE SUPPLY	AW-2669	27-6-68
SPACED	AW-2634	4-4-68
AMENDMENTS	AUTHORITY	DATE

FOR EXPLANATION OF DIMENSIONING, ETC., SEE P.A.D. NOTE SHEET NO. 1

THIRD ANGLE PROJECTION SEALED

DIMENSIONS ARE IN INCHES

SCALE 1/1

DRAWN BY [Signature] TRACED BY [Signature] 197 CAD

EXAMINED BY [Signature] F CKD [Signature]

BRUSH, FILE 762MM X 51 G3
CLEANING EXTENSION BARREL

ST-100202

Certified Correct Copy of Section
 Drawings at this Date 23-01-82

Handwritten signature
 F/A
 2

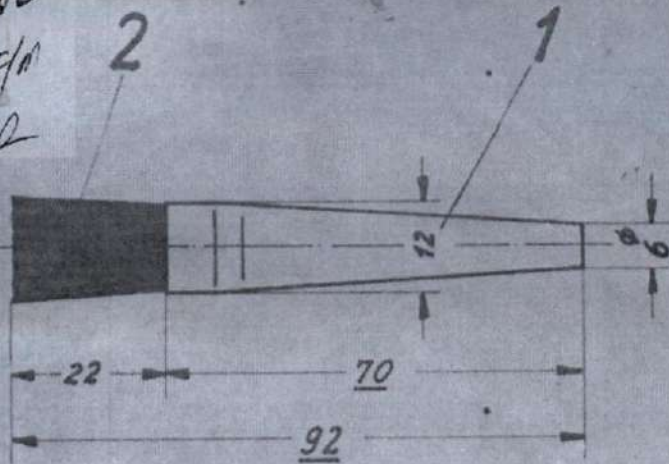

Handwritten signature
 Schull

Maße ohne Toleranzangabe nach		grob		DIN 7168		Brush cleaning Small Arms CLEANING PENCIL		SALE	
Tag		Name		1090-20-100-6675		Reinigungspinsel		Mußstab	
Bearb. 7.7.64		Saler						1:1	
Gepr.								Vervielf.-Paar	
Norm.						79002		Nr	
Sealed		AW-2103		BWB - WIT 1					
		21-10-68							
And-zust.		And.-Mittlg.		Tag		Name			

Handwritten word
 cleaning

Lfd. Nr.	Stückzahl	Benennung	Name	Sach-Nr. Index	DIN A	Bemerkungen
1		White Sheet metal Weißblech H 13 0,2 Werkstoff: <i>see drawing</i>	<i>see drawing</i>	79 002 - 00.01		Quantity according to order Menge n. Bedarf
2		Bristles Sheet (of good commercial quality) Borsten, falbe (a. VTL)		79 002 - 00.02		Quantity according to order Menge n. Bedarf
		work material				
		bristle or horse hair				

PRO
 ISSUED
 AM P.Y.R. QTY. 01
 SIG 03-12-24

Material		AW-3463		Brush cleaning Small Arms		Liste best. aus...Blatt	
Arbeits		11-6-74		Cleaning Pencil		Blatt Nr...	
AW-3475		16-10-73		Reinigungspinsel		Vervielf.-Paar	
Part No. 2				1090-20-100-6675		5	
White Sheet		AW-3412		79 002		Nr.....	
Metal		19-8-73					
And-zust.		And.-Mittlg.		Tag		Name	

Part No. 1090-20-100-6675

cancel/nd no. 14-86

GA-Rbl 26-11-85

Certified Correct Copy of Approved Drawing at this date 2-80
for Chief Inspector of Arms
(S. GUNAYUR-UL-HASNAW)

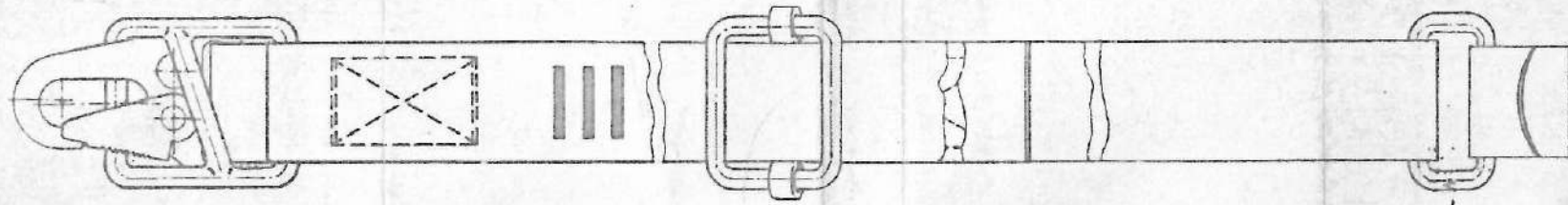

100407/3-810

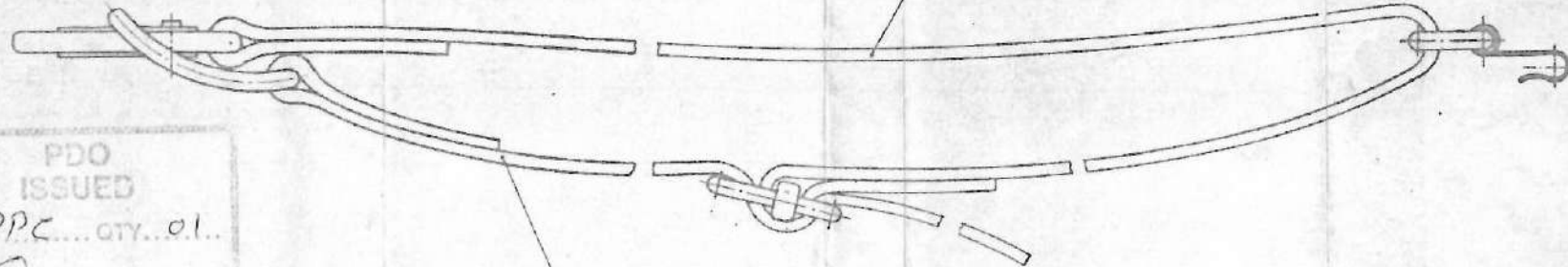

100407/3-820

PDO ISSUED
A.M. PPC... QTY... 01...
DT 01-11-24



25.11.85

										Werk-Nr. 205506	
										Z.Nr.	
										Gewicht kg	
										0,1046	
										Wicklung, Wickelart:	
										1971	
										Bauh. 10.10	
										Dep.	
										Norm	
										Beschreibung MULTIPURPOSE CARRYING SLING	
										Bereitschaftsträgerriemen	
										R 3/3 SMALL ARMS M.F. 30	
										Z.Nr. 100407/3-800	
										Ersatz Nr Zeichn. Nr. v. 21.772 Ausg. b	
										HECKLER & KOCH	
										GERMANY	

CIA No. WA 23002/MP5A2 It. 26-1-2001