



POF 1262
(FOREIGN SUPPLIES)

Government of Pakistan
PAKISTAN ORDNANCE FACTORIES
TENDER ENQUIRY

To

M/s

Dear Sirs,

Reference : TENDER ENQUIRY NO. 0002/FP/HVN/55

DATED 03-MAR-25

You are requested to submit quotations for the item(s) noted in the schedule to the tender. Please note the following instructions for filling the tender:-

1. SUBMISSION OF TENDER

- 1.1 Tenders will be opened at 10:30 hours on 15-APR-25 at Bidding Centre adjacent to Rabita Hall, Pof Wah Cantt. Quotation must be submitted electronically on www.ebidding.pof.gov.pk as well as in hard form (duly sealed in envelope) before 30 minutes of opening time. The tender received late will not be entertained. You may witness the opening of the tender if you so desire. If a representative is deputed, he should bring a letter of authority from you.

Tender Enquiry No: 0002/FP/HVN/55
Tender to be opened on: 15-APR-25
Address as follows:-

(www.ebidding.pof.gov.pk) **BID CENTER**
ADJACENT TO RABITA HALL
POFs, WAH CANTT.

2. GENERAL INSTRUCTIONS REGARDING PREPARATION OF QUOTATIONS

- 2.1 **For Materials**, the prices should be filled in column 5 and delivery date in column 6 of the schedule to this Tender Enquiry. As per **PPRA Rule 36(b) i.e Single Stage two envelope method** will be utilized for "Open competitive bidding." Moreover, technical & commercial evaluation of Bids will be carried out strictly as per PPRA rules and contract(s) will be awarded to the most advantageous bidder(s).
- 2.2 **For Plant and Machinery**, you are required to quote in two parts:-
Part I "Technical Offer": It should exclusively give technical details and literatures/brochures of the offered plant, machinery and equipment; validity date; delivery schedule; and signed undertaking to this Tender Enquiry. It must not indicate price, costs etc.

Cont....P-2

Part II "Commercial Offer": It should indicate the commercial terms e.g. price, terms of payment, mode of payment, mode of supply.

- 2.3 The quotation must remain valid for, at least 90 days from the date of opening of commercial tenders, extendable if so desired.
- 2.4 The quotation should hold good for any reduced or enhanced quantities without notice.
- 2.5 In the event of non-acceptance of offer, intimation may be given to the Tenderers on their request.
- 2.6 Conditional offers or alternative offers are likely to be ignored.
- 2.7 Quotations should be based on FOB. The consignment will be shipped through Pakistan National Shipping Corporation (PNSC). In case there is no PNSC service in the country of shipping, please quote on C & F basis. The freight should be indicated separately. Insurance premium should not be included in the quoted price. However, where insurance is considered necessary, advice to that effect should be given in the quotation.
- 2.8 Submission of the offer through an agent in Pakistan should be avoided. In case it is considered inevitable, the agent's quotation must invariably be accompanied by the original proforma invoice from the principals / manufacturers.
- 2.9 Country of origin and port of shipment to be stated.
- 2.10 Suppliers will render/attach necessary information regarding hazardous effects on environment, of the materials/products supplied by them, with their quotations and shipping/despatch documents.
- 2.11 If the requisite information is not furnished along with the quotation or offer received is not in conformity with the requirement of the T.E, such offer shall be ignored.

3. INSPECTION

- 3.1 Supplies shall be subject to the inspection and acceptance by the competent inspection authority nominated by the Purchaser, who will arrange it at his own cost. Inspection facilities such as tools, test equipment, instruments etc will, however, be provided by the Suppliers in accordance with the relevant specifications
- 3.2 Where considered necessary by the Purchaser, stores may be obtained on Warranty/Guarantee, subject to inspection on receipt. Rejected stores will be removed and replaced with the acceptable stores by the Supplier at his own expense, within a specified time.

3.3 TENDER SAMPLE

Purchase officer may require a tender sample, and the same must be provided within two weeks of receipt of intimation to this effect. Tender sample must be according to the description given in Tender Enquiry. Firm that fail to provide tender sample within stipulated time will not be entertained excepting the established and reputable firms who have either previously satisfactorily supplied the same or similar stores or have submitted an acceptable sample thereof against previous T.E.

4. ACCEPTANCE OF OFFERS

- 4.1.1 The procuring agency may reject all bids or proposals at any time prior to the acceptance of a bid or proposals. The procuring agency shall upon request communicate to any supplier or contractor who submitted a bid or proposal, the grounds for its rejection of all bids or proposals, but is not required to justify those grounds.

4.1.2 Procuring agency shall incur no liability, solely by virtue of its invoking sub-rule (1.1) towards suppliers or contractors who have submitted bids or proposals.

4.1.3 Notice of the rejection of bids or proposals shall be given promptly to the concerned suppliers or contractors that submitted bids or proposals.

4.2 PERFORMANCE BOND

(a) The successful bidder will provide Performance Bond at the rate up to 10% of F.O.B value of the contract in favour of Controller Military Accounts (CMA) POF Wah Cantt. The Performance Bond will be furnished in the form of Deposit At Call Receipt (CDR) from any scheduled bank in Pakistan or an unconditional bank guarantee on prescribed proforma covered by any scheduled bank in Pakistan. The performance Bond shall be furnished within 45 days from the date of opening of Letter of Credit. It shall be valid for a period of 12 months after the date of expiry of letter of credit. If the Performance Bond is not furnished within the prescribed time of 45 days, the Purchaser reserves the right to:

i. Impose penalty @ 1% per month of the value of CDR/BG.
(Clause-42 (a i) is not applicable in case of procurement of Plant/Equipment/Machinery items).

OR

ii. Cancel the contract and make other arrangements for purchase of the stores at the risk and expense of the Supplier.

(b) No Performance Bond will be required if the total FOB value of the contract is less than US \$50,000 and contract is placed directly on the foreign Supplier.

4.3 FAILURE TO SUPPLY THE STORES

All deliveries must be completed by the specified date. If the failure to deliver the stores within the scheduled time should have arisen from "Force Majeure", which the purchaser may admit as reasonable ground for further time, he will allow such additional time as he may consider to have been required by the circumstances of the case. Otherwise, he will be entitled, at his discretion, to cancel the contract; and/or, claim liquidated damages upto 2% but not less than 1% of the contract price of the items and their quantities for each and every month or part of a month, beyond the specified delivery date, during which these may not be delivered, subject to a maximum of 10% of the total contract value of the particular stores which remained unsupplied either in part or in full: or, to purchase from elsewhere, the unsupplied stores at the risk and cost of the supplier:

4.4 PAYMENT

Payment will normally be made by means of irrevocable letter of credit. Unless otherwise stated 90% payment will be released on submission of despatch documents to Bank while balance 10% payment will be released on receipt and acceptance of store by the consignee.

All Bank charges incurred in Pakistan in connection with the establishment of L.C. will be borne by the Purchaser, whereas all Bank charges incurred in connection with drawing of payment including charges for confirmation of L.C. by the advising Bank/Foreign Bank will be borne by the Supplier.

5. BID Security

5.1 A copy of Bid Security should accompany the tender in shape of deposit at call receipt/Pay Order/Banker Cheque from scheduled bank drawn in favour of :-

M.D-POF HAVELIAN CANTT

5.2 Bid security instrument in original must be provided on the day/date of tender opening in the Bid Center as under:

- a. Registered/indexed firms including foreign firms - 2% of quoted value subject to the maximum ceiling of Rs. 0.5 Mn.
- b. Registered/un-indexed firms including foreign firms - 3% of quoted value subject to the maximum ceiling of Rs. 0.75 Mn.
- c. Un-Registered firms including foreign firms - 5% of quoted value subject to the maximum ceiling of Rs. 1.00 Mn.
- d. Gov. organization/Production Units/State owned enterprises/welfare projects of Svcs HQ - Rs 0.5 Mn can be waived off on request by DG(C).
- e. Bid money will be returned to unsuccessful (less first three lowest quotee firms) bidders on opening of commercial offers
- f. Bid money will be returned to successful bidders on submission of performance bond/unconditional B.G.
- g. Bids will be conditionally accepted if Bid Money deposited by firms is less than the given amount. However, the firms will be required to deposit additional amount within 10 x days of opening of Bids.
- h. Offers received without Bid Security will not be entertained.
- i. Bid Money will be forfeited in case the quotation is withdrawn before the expiry of its validity date.

6. SECURITY OF INFORMATION

The tenderer and his employees must not communicate any information relating to the sale/purchase of stores under this enquiry to any person other than the manufacturer or to any press or agent not authorised in writing by POFs to receive it.

WARNING

In case the firm abstain from making offers or fail to acknowledge the tender form by the specified date on three consecutive occasions, no further tender enquiry may be issued to them and their names would liable to be removed from the approved list.

Yours Faithfully

(BATOOL BIBI)

MANAGER

for PAKISTAN ORDNANCE FACTORIES

Tele 0992-810001,3/287

Fax 0992-810318

Telex mdhvn@pof.gov.pk

PAKISTAN ORDNANCE FACTORIES

SCHEDULE TO TENDER NO. 0002/FP/HVN/55DATED 03-MAR-25**(1) FOR MATERIALS**

(1)	(2)	(3)	(4)	(5)		(6)
Item No.	Description with Specs. etc.	Unit	Qty	Price Per Unit FOB or free delivery		Delivery Date
				In Figures	In Words	
1	CUTTING DISC DIA 663 MM MATERIAL XC ALLOY ,DRG# DOE/M-1/0351 (Garniture) having 06 segments Rotor+06 segment Stator, DR3 Element Diameter-663mm (KF) CHEMICAL COMPOSITION OF MATERIAL C-2.95-3.30%,Si=1.40-1.60%,Mn=1.15-1.25%,P=0.035% Max,S=0.30%Max,Cr=23.5-24.5%,Mo=0.45-0.55%,Ni=0.90-1.10%,Cu=0%&Fe=Rdr% Hardness 57-60 HRC	NO	12			IMMEDIATE

**(2) For Plant & Machinery:
Specification:-****(3) Special Conditions**

1. Quotation submitted on Schedule to T.E must be signed/stamped.
2. Quotation Strictly according to our requirement, specification and TE term and conditions. Quote all parameter of specification/material composition and the bid being technically deviated from any parameter /material composition of the specification and drawing shall be outrightly rejected.
3. The firms will only submit one offer as per our TE requirement However, any firm offering multiple options will be excluded from technical scrutiny and offer will be rejected on spot.
4. Foreign Firms are allowed to quoted either on FOB or C&F Karachi. However, in case of C&F sea freight charges may be mentioned separately.
5. Offer should only be forwarded if the supplier has authorization /Export permit for export of store.
6. All Chinese and Hong Kong based firms must quote rates in RMB (Chinese Yuan) and rates in other currency will not be entertained
7. New entrant firms will accept 100% Payment after receipt acceptance of store at POF HVN.
8. To provide advance sample if demanded/required by POF.
9. Inspection of the store will be carried out by QC- POF Havelian.
10. Undertaking of T.E schedule should be returned duly signed & Stamped with quotation.
11. Local firms must quote on FOR basis with the provision of:
 - (i) Tender fees (Non returnable) for Rs. 500/- in favour of Dir. Admin POF Wah Cantt.
 - (ii) Bid Security as per T.E Clause 5.
 - (iii) Performance bond in the shape of CDR not more than 10% of contract by successful bidder.

PAKISTAN ORDNANCE FACTORIES

SCHEDULE TO TENDER NO.

0002/FP/HVN/55

DATED

03-MAR-25(4) Undertaking

Should our offer be accepted, we hereby undertake to supply the stores/render the services contracted on the basis of Conditions of Contract embodied in Form POF 1280, and to deposit the performance bond within the prescribed time, failing which it will constitute a breach of contract, and POF will have the right to purchase the stores/services elsewhere at our risk and cost.

Place _____
Date _____Signature of the Tenderer _____
Name _____
Postion _____
Address _____
Income Tax G.I.R. No _____

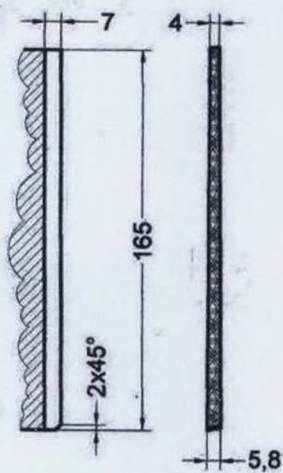
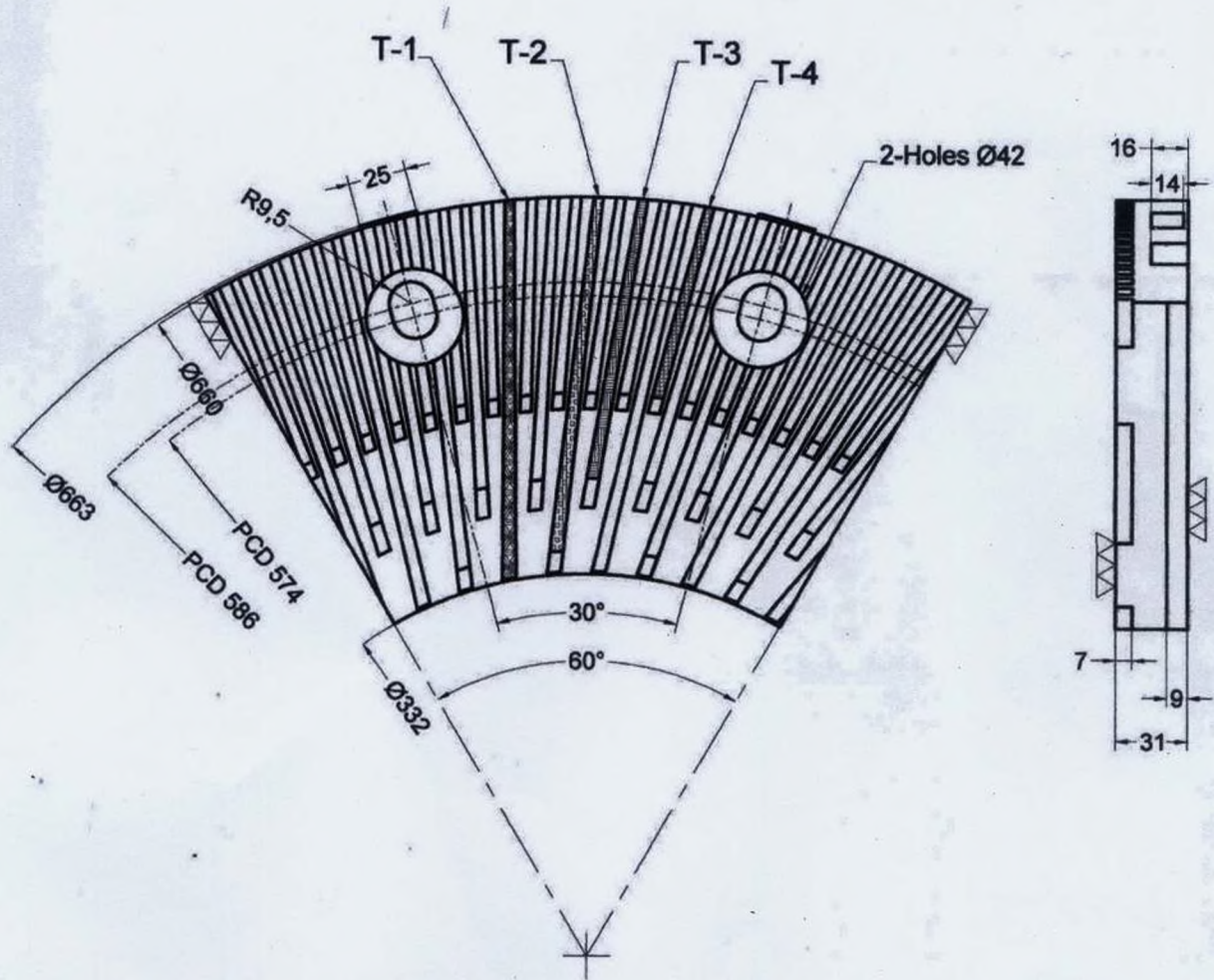

T-1

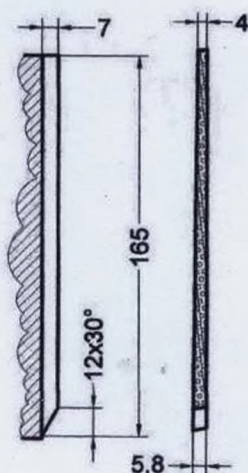

T-2

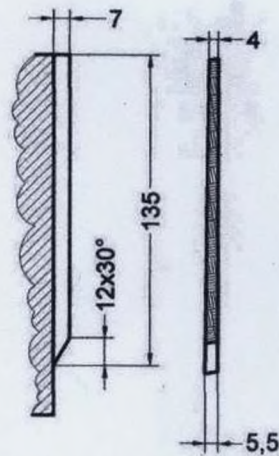

T-3

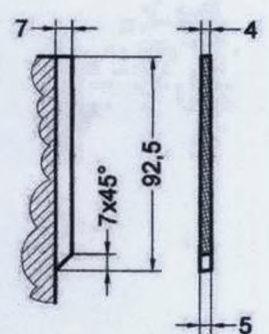

T-4

Note:-

- * Machining allowance may be added.
- * Dimensions are in mm.
- * Weight of 01 Segment = 5.24 Kg

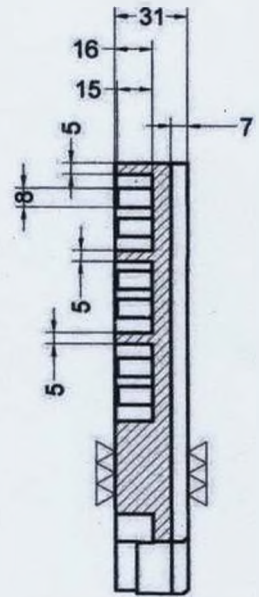
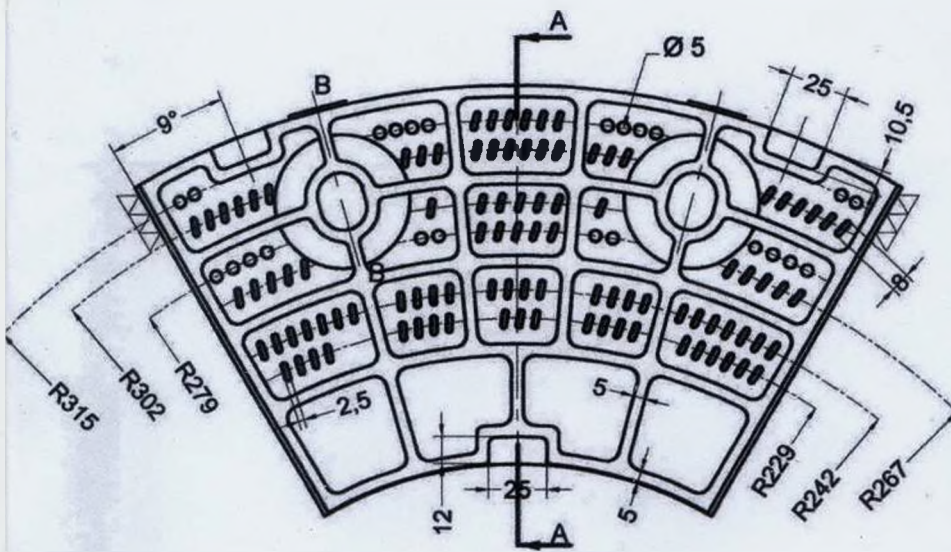

SECTION "A-A"

CONTROLLED COPY

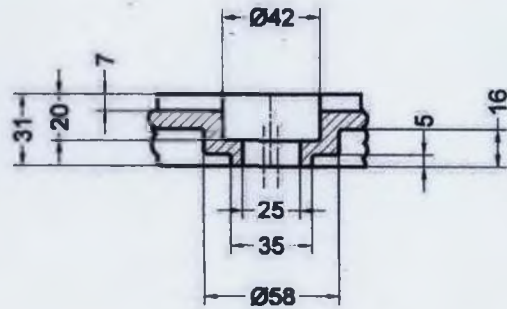

SECTION "B-B"

02	STATOR	XC-Alloy	06	
01	ROTOR	XC-Alloy	06	
Sr. #	Description	Matl.	Qty.	Remarks
DRAWN M. S. ALAMI SM EHSAN		D' Man	C' Man	
TRACED				
CHECKED <i>[Signature]</i>		T.O - D.O.E		
APPROVED <i>[Signature]</i>		MGR-MECH & SER		
DATE 29-10-2020				
SCALE N.T.S		AMENDMENT		SIGR.
TITLE				SEC. MSBP-1
				GROUP M-1
POF HAVELIAN CANTT				DRG No.
CUTTING DISC GARNITURE Ø 663				D&E/M-1/0351
ROTOR + STATOR DR3 ELEMENT (KF)				FILING No.
BASED ON SAMPLE		No. OF SHTs.	01	P/01081/A
VETTED BY <i>[Signature]</i>		SHT No.	01	