



GOVERNMENT OF PAKISTAN
PAKISTAN ORDNANCE FACTORIES
TENDER ENQUIRY

To

Dear Sirs,

Reference: - TENDER ENQUIRY NO. 3521-2-9-50-Capt-Pur-AA, dated 05-4-2021

You are requested to submit sealed quotations for the item noted on the Schedule to the Tender. Please note the following instructions for filling the tender:-

1. **SUBMISSION OF TENDER**

- 1.1 Tenders will be opened at 1230 hours on 25-5-2021 and must reach this office on or before that time. The tender received late will not be entertained. You may witness the opening of the tender if you so desire. If a representative is deputed, he should bring a letter of authority from you.
- 1.2 Only one tender should be included in one envelope. The outside of the envelope should be inscribed with: -

Tender Enquiry No: 3521-2-9-50-Capt-Pur-AA, dated 05-4-2021

Tender to be opened on: 25-5-2021

Address as follows:-

**Managing Director
Artillery Ammunition Factory
Pakistan Ordnance Factories,
Wah Cantt, Pakistan.
Fax : 051-9314100 & 051-9271400
Email : mdaa@pof.gov.pk**

- 1.3 If envelope do not indicate reference of TE or received late, the same will be returned un-opened.

Contd...

2. **GENERAL INSTRUCTIONS REGARDING PREPARATION OF QUOTATIONS**

- 2.1 For materials, the prices should be filled in column 5 and delivery date in column 6 of the schedule to this Tender Enquiry. The undertaking should be signed at the bottom of the Schedule which shall form the Quotation. You may use a separate sheet if necessary.
- 2.2 For Plant & Machinery, you are required to quote in two parts:-
- Part-I "TECHNICAL OFFER" It should exclusively give technical details and literatures/brochures of the offered plant, machinery and equipment; validity date; delivery schedule; and signed undertaking given on the schedule to this Tender Enquiry. It must not indicate price, costs etc.
- Part-II "COMMERCIAL OFFER" It should indicate the commercial terms e.g. price, terms of payment, mode of payment, mode of supply.
- Each part should be placed in a separate sealed cover. The envelope should be inscribed with Part-I "Technical Quotation without Price" and Part-II "Commercial Quotation with Price".
- 2.3 The quotation must remain valid for, at least 90 days from the date of opening of tenders.
- 2.4 The quotation should hold good for any reduced or enhanced quantities without notice.
- 2.5 In the event of non-acceptance of offer, intimation may be given to the Tenderers on their request.
- 2.6 Conditional offers or alternative offers are likely to be ignored.
- 2.7 Quotations should be based on FOB. The consignment will be shipped through Pakistan National Shipping Corporation (PNSC). In case there is no PNSC service in the country of shipping, please quote on C & F basis. The freight should be indicated separately. Insurance premium should not be included in the quoted price. However, where insurance is considered necessary, advice to that effect should be given in the quotation.
- 2.8 Submission of the offer through an agent in Pakistan should be avoided. In case it is considered inevitable, the agent's quotation must invariably be accompanied by the original proforma invoice from the principals/ manufacturers. **However, contract will be placed on principals / manufacturers.**
- 2.9 Country of origin and port of shipment to be stated.
- 2.10 The offer of principal must clearly indicate whether the rate quoted is inclusive of agent's commission, and if inclusive rate of commission included be specified.
- 2.11 Supplier will render necessary information regarding hazardous effects on environment, of the materials/products supplied by them, in their quotations and shipping/despatch documents.
- 2.12 If the requisite information is not furnished on the TE form or offer received is not in conformity with the requirement of the TE, the offer shall be ignored.

Contd...

3. **INSPECTION**

- 3.1 Pre-shipment inspection / acceptance of the machine at firm's premises will be conducted by the team deputed on training.
- 3.2 The supplier will provide Warranty / Guarantee Certificate of the machine, equipment & accessories which will be valid for a period of 12 x months after successful installation & commissioning of the machine.

4. **ACCEPTANCE OF OFFERS**

- 4.1.1 The procuring agency may reject all bids or proposals at any time prior to the acceptance of a bid or proposal. The procuring agency shall upon request communicate to any supplier or contractor who submitted a bid or proposal, the grounds for its rejection of all bids or proposals, but is not required to justify those grounds.
- 4.1.2 Procuring agency shall incur no liability, solely by virtue of its invoking sub-rule (1.1) towards suppliers or contractors who have submitted bids or proposals.
- 4.1.3 Notice of the rejection of all bids or proposals shall be given promptly to all suppliers or contractors that submitted bids or proposals.

4.2 **PERFORMANCE BOND**

- (a) The successful bidder will provide Performance Bond at the rate of 10% of FOB value of the contract in favour of Controller of Military Accounts (CMA), Wah Cantt. The Performance Bond will be furnished in the form of Deposit At Call Receipt (CDR) from any scheduled Bank in Pakistan or an unconditional bank guarantee on prescribed Proforma covered by any schedule bank in Pakistan. The Performance Bond shall be furnished within 45 days from the date of opening of Letter of Credit. The same will be got extended upto 12 x months after successful installation & commissioning of the machine accordingly. If the Performance Bond is not furnished within the above mentioned prescribed time, the Purchaser reserves the right to cancel the contract and make other arrangements for purchase of the stores at the risk and expense of the Supplier.
- (b) No Performance Bond will be required if the total FOB value of the contract is less than US \$ 50,000 and contract is placed directly on the foreign supplier.

4.3 **FAILURE TO SUPPLY THE STORES**

All deliveries must be completed by the specified date. If the failure to deliver the stores within the scheduled time should have arisen from "Force Majeure", which the Purchaser may admit as reasonable ground for further time, he will allow such additional time as he may consider to have been required by the circumstances of the case. Otherwise, he will be entitled, at his discretion, to cancel the contract; and/or, claim liquidated damages upto 2% but not less than 1% of the contract price of the items and their quantities for each and every month or part of a month, beyond the specified delivery date, during which these may not be delivered, subject to a maximum of 10% of the total contract value of particular store which remained unsupplied either in part or in full or, to purchase, from elsewhere, the unsupplied stores at the risk and cost of the Supplier.

4.4 **PAYMENT**

- i. 70% payment will be released through LC against shipping documents including Acceptance Certificate signed by PSI team, confirming satisfactory pre-shipment inspection.
- ii. 30% payment will be paid through LC upon final acceptance subject to the following certifications signed by Inspection Team and MD-AA:-
 - a. Successful installation & commissioning of machine at POF premises.
 - b. Successful production of 200 x components each to Drg #. SK/COM-7620, SK/COM-7619 & SK/COM-7677 on the machine.

All Bank charges incurred in Pakistan in connection with the establishment of LC will be borne by the Purchaser, whereas all Bank charges incurred in connection with drawing of payment including charges for confirmation of LC by the advising Bank/Foreign Bank will be borne by the Supplier.

5. **SECURITY OF INFORMATION**

The tenderer and his employees must not communicate any information relating to the sale/purchase of stores under this enquiry to any person other than the manufacturer or to any press or agent not authorized in writing by POFs to receive it.

Please return the Schedule to the Tender duly signed by the specified date, along with the specifications drawings etc. if any, enclosed herewith - even if you are unable to quote.

WARNING

In case the firm abstain from making offers or fail to return/acknowledge the tender form by the specified date on three consecutive occasions, no further tender enquiry may be issued to them and their names would liable to be removed from the approved list.

Yours faithfully,

(Waqas Ahmad)

Managing Director-AA

For and on behalf of the President
of Islamic Republic of Pakistan

PAKISTAN ORDNANCE FACTORIESSCHEDULE TO TENDER NO. 3521-2-9-50-Capt-Pur-AA, Dt. 05-4-2021**(1) FOR PLANT AND MACHINERY**

(1)	(2)	(3)	(4)	(5)		(6)
Item No.	Description with Specs etc.	Unit	Qty.	Price Per Unit (FOB Value)		Delivery Date
				In Figures	In Words	
1	CNC Single Spindle Machine Capacity 42mm 2-Axis	No.	01			

- (2) Specifications: Enclosed as Annexure-'A' & 'B'
 (3) Special Conditions: Enclosed as Annexure-'C'
 (4) Tech. Comparison: Enclosed as Annexure-'D'

Note:- **SINGLE STAGE-TWO ENVELOPE PROCEDURE:**

- i. The bid shall comprise a single package containing two envelopes. Each envelope shall contain separately the technical and financial proposal.
- ii. The envelope shall be marked as "Technical Proposal" & "Financial Proposal" in bold and legible letters to avoid confusion.
- iii. Initially, only the envelope marked "Technical Proposal" shall be opened.
- iv. The envelope marked as "Financial Proposal" shall be retained in the custody of Bid Centre.
- v. During the technical evaluation, no amendments in the technical proposal shall be permitted.
- vi. The financial proposals of bids shall be opened publicly at a time, date and venue announced and communicated to the bidders in advance.

(5) UNDERTAKING:

Should our offer be accepted, we hereby undertake to supply the stores/render the services contracted on the basis of Conditions of Contract embodied in Form POF 1282, and to deposit the performance bond within the prescribed time, failing which it will constitute a breach of contract, and POF will have the right to purchase the stores/services elsewhere at our risk and cost.

Place _____
Date _____

Signature of Tenderer _____
Name _____
Position _____
Address _____
Income Tax G.I.R No. _____

SPECIFICATION

1. Nomenclature & Description:

CNC Single Spindle Machine Capacity 42mm 2-Axis Qty. 01 No.

2. Technical Requirements:

i.	Bar Capacity of Main Spindle	42 mm
ii.	Max. Swing	300 mm
iii.	Max. Turning Dia	250 mm
iv.	Spindle Speed	0 to 4500 RPM
v.	Spindle Bore	To suit Rod dia 42mm
vi.	Spindle Type	Belt Driven with External Motor
vii.	Turning length	400 mm
viii.	Main drive motor rating	20 KW
ix.	No. of Turret	01
x.	No. of stations in Turret	12
xi.	No. of driven tools in Turret	8
xii.	Turret Travel in X-axis	200 mm approx
xiii.	Turret Travel in Z-axis	450 mm approx
xiv.	Nominal shank size of Holder	VDI-30

3. CNC Control:

FANUC / SIEMENS / MITSUBISHI (Latest version)

4. Features:

- i. Automatic lubrication system
- ii. Reinforced Concrete Slant Bed
- iii. High pressure coolant supply in Turrets
- iv. Automatic tail Stock with Center

5. Software:

- i. Integrated Diagnostic System
- ii. Initialization Procedure
- iii. Back Up
- iv. Re Loading
- v. Calibration
- vi. Up gradation

Contd...

6. Accessories:

- i. Standard collets 10 to 42 mm Dia
- ii. Work piece catcher
- iii. Swarf conveyer
- iv. LNS Hydro Bar Feeder
- v. Standard tool holders for turning, threading, boring, reaming, Tapping, drilling all type with accessories
- vi. Collets for tool holder
- vii. Power driven tool holder for drilling, milling, slotting with accessories
- viii. Adjustable stock stop
- ix. Inbuilt voltage stabilization
- x. Cooling system for hydraulic unit
- xi. Air Conditioning Unit for control cabinet
- xii. Machine light
- xiii. Cooling System for Cutting Oils
- xiv. Lap top
- xv. Tool Pre-setting device
- xvi. Safety Guards
- xvii. Spindle Nose DIN 55026/A8

7. Applicable Standard:

- i. ISO 230-1-2012
- ii. ISO 230-2-2012/2014
- iii. VDI-DGQ 3441
- iv. ISO 230-5:2000
- v. ISO 841:2001 (E)

8. Tooling:

- i. Set of tool holders
- ii. Package cutting tools
- iii. Package equipment / accessories and tooling required for the machining of work piece to Drg # SK/COM-7620, SK/COM-7619 & SK/COM-7677.
- iv. 01 x Tool Kit for running & planned maintenance of the machine

9. Spares:

Electrical, Electronic & Mechanical spare parts for 02 x years running maintenance

Contd...

10. Documentation:

04 x sets of following documents in English language are required:-

- i. Electric Sequence Control Circuit Diagram of machine
- ii. Details of motors and their control
- iii. Operating, maintenance and service manual
- iv. Working drawing of cutting tool and equipment

11. Site Condition & Available Services:

- i. The available electric system on site for functioning of the machine is:-
 - a. 400 ± 5% VAC, 50Hz, 3 Phase, 4-Wire System
 - b. 220 ± 5% VAC, 50Hz, 1 Phase
- ii. The available compressed air supply on site for functioning of the machine is 6 bar.
- iii. The electric equipment should be earthed.
- iv. Equipment should have line protection circuit breakers with thermally delayed overload release and or electro-magnetic quick-acting release, as required. It should be followed by cut-out and safety fuses, if necessary.
- v. All motors should be appropriately protected.
- vi. The industrial electrical measuring instruments, wherever used should have an accuracy of Class-I or better.

The available climatic conditions for functioning of the machine are:-

- i. Temperature:-
 - a. Winter = - 3⁰ to + 20⁰ C
 - b. Summer = 30⁰ to 50⁰ C
- ii. Relative Humidity = 25 to 90%
- iii. Earthquake Value = 8.5 on Richter scale

12. Safety:

Safety devices in accordance to international standards must include the followings:-

- i. Over Current Tripping System
- ii. Safety guards for rotatory parts must be provided.
- iii. Mechanical Overload Protection
- iv. Electronic Overload Protection

13. Training:

Free of cost training for 02 x weeks for 02 x POF Engineers / Technicians on operation and maintenance.

Contd...

14. Pre-shipment Inspection:

- i. Pre-shipment inspection / acceptance of machine at firm's premises will also be conducted by the team deputed on training. The inspection team besides others will particularly carry out trial run of the machine and it will be considered acceptable subject to satisfactory production of 100 x components each to Drg #. SK/COM-7620, SK/COM-7619 & SK/COM-7677 on the machine.
- ii. The inspection of produced components will be carried out through gauges, SMEs and through enlargement where possible. Provisioning of applicable gauges will be made by purchaser whereas arrangements for SMEs and enlargement will be made by supplier.
- iii. Specified material will be used for production of components during PSI.
- iv. The provisioning of material will be made by the firm.
- v. Air tickets, Boarding & Lodging, DA and inland transportation in respect of training & PSI teams would be the responsibility of the supplier.

15. Installation & Commissioning:

- i. Installation & commissioning of the machine is the responsibility of supplier.
- ii. POF will provide services and manpower to help during installation & commissioning.
- iii. All safety risks associated with installation & commissioning are the responsibility of supplier.
- iv. Needed material for installation & commissioning would be managed by the supplier.
- v. The supplier will provide information regarding total man-weeks of its engineers/technicians required for installation, commissioning and trial production run of the machine. All expenses, including boarding & lodging, air travel and daily allowances of the engineers/ technicians are to be borne by the supplier. However, local transportation shall be arranged by the purchaser.
- vi. The supplier will indicate the time schedule for installation and commissioning of the machine.
- vii. The machine after installation and commissioning shall be accepted on firm's warranty / guarantee. The warranty / guarantee shall be binding on the supplier for a period of 12 x months reckoning from the date of commissioning of the machine.

16. Final Acceptance Test:

- i. Final acceptance test will be performed at purchaser's premises.
- ii. The machine will be run for trial to check abnormal noise, vibration, heat up, leakages etc.
- iii. Machine accuracies will be checked as per following criteria:-
 - a. Positional uncertainty & repeatability test standard for linear Axis VDI-DGQ 3441
 - b. Geometrical accuracy test ISO 230-1-2012
 - c. Positional uncertainty for all linear axes $\leq 0.03\text{mm}$ for entire stroke
 - d. Repeatability for all linear axes $\leq 0.02\text{mm}$
 - e. Spindle run out $\leq 0.01\text{mm}$
 - f. Accuracy of angular movement ≤ 25 arc sec as per standard ISO-230-2-2014

Contd...

- iv. The machine will be run for trial. A number of 200 x components each to Drg #. SK/COM-7620, SK/COM-7619 & SK/COM-7677 will be produced on the machine. Material will be provided by POF.
- v. The inspection of produced components should be 100% acceptable.
- vi. Based on successful inspection report, a certificate will be issued by purchaser in respect of successful installation and commissioning of the machine.
- vii. The firm will provide on job training on the machine to Engineers / Technicians at purchaser's premises.

17. Payment Terms & Conditions:

- i. Payment terms and conditions are negotiable. 70% payment will be released through LC against shipping documents including Acceptance Certificate signed by PSI team, confirming satisfactory pre-shipment inspection.
- ii. 30% payment will be paid through LC upon final acceptance subject to the following certifications signed by Inspection Team and MD-AA:-
 - a. Successful installation & commissioning of the machine at POF premises
 - b. Successful production of components on the machine
- iii. The firm will provide performance bond @ 10% FOB value of the contract in the shape of bank guarantee before shipment. Same guarantee will be valid for 12 x months after successful installation and commissioning of the machine.

18. Delivery Schedule:

- i. Delivery of the machine will be made within 06 x months from placement of contract. However, the same can be negotiated.
- ii. Delivery of the machine will be made on C&F basis.

19. Country of Origin:

Europe, UK, USA, Japan, China & Korea

20. Colour:

Green RAL-6011

DIMENSIONS IN MM

Annexure-'B'
Page 1 of 3

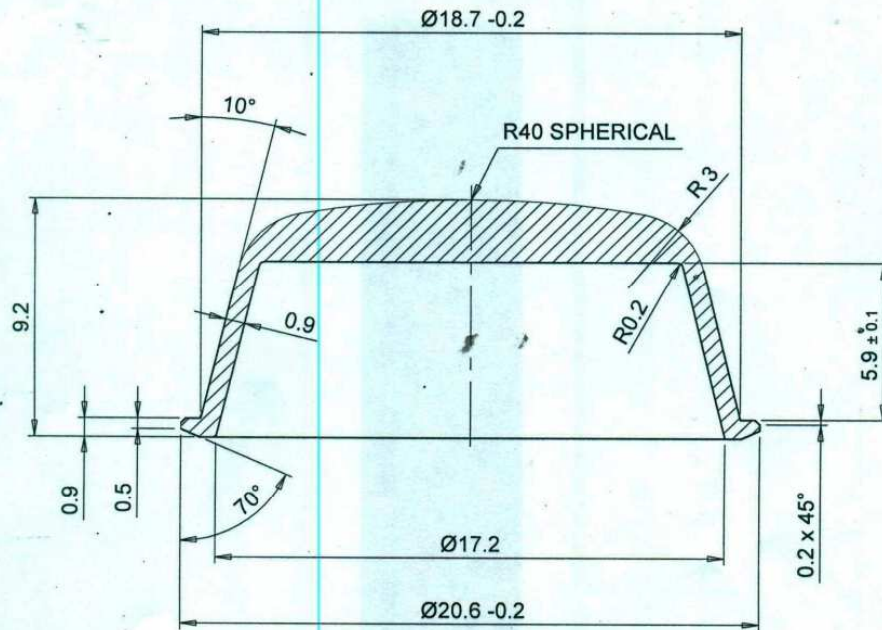

MATERIAL :

ALLUMINIUM ALLOY ROD AU4 Pb x 646 (IU- 921006) OR
ALLUMINIUM ALLOY ROD BS - 1474 DESIG. 2014 A CONDITION T4.

PROTECTIVE FINISH

ANODIZING TO SPECIFICATION DEF - STAN - 03-25/3

DRAWN. *M.Azeem-A.T.O*

CHECKED. *M.Anwar-T.O.*

APP' VD.
Ghufran Ullah-A.M.

ARTILLARY AMMO. FY.
PAKISTAN ORDNANCE FACTORIES
WAH CANTT PAKISTAN

DRG. NO.
SK/COM - 7620

DATE:- 06-01-2020

SPECIAL CONDITIONS

- a) **TO BE FULFILLED AT THE TIME OF BIDDING / REPLY OF TENDER ENQUIRY**
- i. It may be confirmed that you will be able to obtain export license from your Govt. in the event of successful bidding.
 - ii. OEM/authorized suppliers with company profile/brochure.
 - iii. Performance of such type of machine supplied to various customer.
 - iv. Backup service in Pakistan.
 - v. Item wise price of machine, equipment & accessories alongwith Electrical, Electronic and Mechanical Spare Parts for 02 x years running maintenance should be quoted as part of commercial offer (Part-II). Essential maintenance & operational spares shall be supplied and ensure backup support for provisioning of spares for 10 years.
 - vi. Reference Column 2.2 of Tender Enquiry Form No. 1262, any indication whatsoever of the price in Part-I of the quotation will render it invalid and void.
 - vii. The supplier must fill in the Proforma of Technical Comparison enclosed as Annexure-‘D’ to the specifications and submit alongwith the offer for our instant evaluation of the offer and enclose it alongwith technical offer.
 - viii. The supplier will provide necessary brochures and technical literature alongwith Part-I of the offer (Technical Offer).
 - ix. POF shall deal directly with the manufacturer / supplier of the machine. In case of manufacturer / supplier chooses to have a local agent, payment of agent’s commission etc., shall be supplier’s responsibility and shall not be included in the price quoted in Part-II of the offer (Commercial Quotation).
- b) **CONDITIONS TO BE PART OF FORMAL CONTRACT AND MAY BE KEPT IN VIEW BEFORE BIDDING**
- i. 70% payment will be released on submission of shipping documents including Acceptance Certificate signed by PSI team, confirming satisfactory pre-shipment inspection.
 - ii. 30% payment will be paid through LC upon final acceptance subject to the following certifications signed by Inspection Team and MD-AA:-
 - a. Successful installation & commissioning of machine at POF premises.
 - b. Successful production of 200 x components each to Drg #. SK/COM-7620, SK/COM-7619 & SK/COM-7677 on the machine.
 - iii. Item wise price of machine, equipment & accessories alongwith Electrical, Electronic and Mechanical Spare Parts for 02 x years running maintenance should be quoted as part of commercial offer (Part-II). Essential maintenance & operational spares shall be supplied and ensure backup support for provisioning of spares for 10 years.
 - iv. The manufacturer / supplier will train at his premises 02 x POF Engineers/Technicians on operation and maintenance of machine at supplier’s premises, free of cost for 02 x weeks.

Contd...

- v. Pre-shipment inspection / acceptance of machine at firm's premises will be conducted by the team deputed on training. The inspection team besides others will particularly carry out trial run of the machine and it will be considered acceptable subject to satisfactory production of 100 x components each to Drg #. SK/COM-7620, SK/COM-7619 & SK/COM-7677 on the machine.
- vi. The inspection of produced components will be carried out through gauges, SMEs and through enlargement where possible. Provisioning of applicable gauges will be made by purchaser whereas arrangements for SMEs and enlargement will be made by supplier. Specified material will be used for manufacturing of components to Drg #. SK/COM-7620, SK/COM-7619 & SK/COM-7677 during PSI. The provisioning of material will be made by the firm.
- vii. Air tickets for both sides, boarding & lodging, inland transportation and provisioning of payment of 30 % Daily Allowance in respect of training & PSI teams would be the responsibility of the supplier.
- viii. The manufacturer / supplier will ensure supply of foundation drawings and installation manual to the consignee at least two months before shipment of the machine.
- ix. The machine will be installed & commissioned at POF by the supplier's Engineers. The machine will be run for trial and 200 x components each to Drg #. SK/COM-7620, SK/COM-7619 & SK/COM-7677 will be produced on the machine. Material will be provided by POF. The inspection of produced components should be 100% acceptable. POF will pay 75 % of commissioning charges in foreign exchange through LC after successful installation & commissioning of the machine against Commissioning Certificate jointly signed by Commissioning Engineer(s) of the supplier, user of the machine & counter signed by MD-AA. The remaining 25 % of the commissioning charges will be paid in Pak. Rupees on successful commissioning of the machine to the Commissioning Engineer(s) to meet their boarding & lodging charges during their stay at POF-Guest House. Any amount incurred over and above the said amount during boarding & lodging at POF-Guest House will be paid by the Commissioning Engineer(s) themselves against claim bills at the time of check out. Travelling expenses for Commissioning Engineer(s) for both sides will also be borne by the supplier.
- x. The manufacturer/supplier will undertake regarding backup support for provisioning of Mechanical, Electrical & Electronic Spare Parts for 10 years maintenance after commissioning of the machine as and when required by POF. The undertaking shall be furnished by the firm in the shape of a certificate to be issued on the letter head of the firm alongwith the accepted copies of the contract (to be returned to the buyer).
- xi. Four sets of document in English language inclusive of Electric Sequence Control Circuit Diagram of machine, details of motors & their control, operating, maintenance & service manual and working drawing of cutting tools & equipment. These manuals must include comprehensive instructions regarding Operation and Maintenance containing detailed Electrical, Electronic, Pneumatic and Hydraulic Diagrams / Assy. & Sub-Assy. drawings in so far these are related to maintenance of the machine supplied. The maintenance manuals may also include planned preventive maintenance program based on number of Operating Hours or Time Span.
- xii. The manufacturer/supplier will provide performance bond in the shape of Bank Guarantee @ 10% of net FOB (LC) value which will be valid for 12 x months after the date of expiry of letter of credit. The same will be got extended upto 12 x months after successful installation & commissioning of the machine accordingly.

- xiii. The spare parts will be properly tagged with Part No. / Serial No. for identification.
- xiv. The machine must be packed in seaworthy packing and protected adequately & appropriately to the mode of despatch against damages from water or other substances during sea voyage and over land journey to withstand the rough handling involved in transit and provide proper preservation of the machine while held in storage by the consignee.
- xv. The machine must include complete tool kit for running & planned maintenance of the machine.
- xvi. POF will hold no responsibility for any damage occurred during shipment of the machine.
- xvii. The supplier will provide on letter head duly signed and stamped declaration of fees, commissions & brokerage etc. alongwith the accepted copies of the contract.

Signature of the Supplier:

Name_____

Status in the Firm_____

Address_____

Place_____

Date_____

TECHNICAL COMPARISON
(TO BE FILLED BY SUPPLIER)

Sr. #	TENDER SPECIFICATIONS	OFFERED SPECIFICATIONS WITH REFERENCE TO PAGE NO. OF QUOTATION