



GOVERNMENT OF PAKISTAN
PAKISTAN ORDNANCE FACTORIES
WAH CANTT

CORRIGENDUM
INVITATION TO BID

Tender Enquiries Nos. 3521-2-1,2,3 & 4-Capt-Pur-AA for Retrofitting /
Up-gradation of CNC Machines

Following amendment is hereby made in the above cited "Invitation to Bid" uploaded on PPRA website dt. 15-02-2020, published in News Papers (Express Tribune Karachi & Nawa-i-Waqt Islamabad) on 22-02-2020 and TEs uploaded on POF website dt. 17-02-2020.

Clause-3 of "Invitation to Bid" and TEs Clause-1(1.1 & 1.2) "SUBMISSION OF TENDER"

FOR Existing

Read The proposals completed in all respects (bearing the Tender Enquiry reference number and addressed to the undersigned) must reach Bid Centre adjacent to Rabita Hall on or before **02-4-2020** but not later than closing time **12:00** hrs. The Tenders will be opened at **12:30** hrs. on the same date.

NOTE: All other terms & conditions will remain same.

Managing Director-AA-Fy.
Tel: 0092-51-9055-21035
Fax: 0092-51-9271400
E-mail:- mdaa@pof.gov.pk
Dated: 17-3-2020



POF 1262-A
(INDIGENOUS SUPPLIES)

GOVERNMENT OF PAKISTAN
PAKISTAN ORDNANCE FACTORIES
TENDER ENQUIRY

To

Dear Sirs,

Reference: Tender Enquiry No. 3521-2-1-49-Capt-Pur-AA, Dated 12-02-2020

You are requested to submit sealed quotations for the item(s) noted in the Schedule to the Tender. Technical & Commercial offers must be sealed separately. Please note the following instructions for filling the tender:-

1. **SUBMISSION OF TENDER**

1.1 Tenders will be opened at 1230 hours on **19-3-2020** and must reach Bid centre adjacent to Rabita Hall on or before that time. The tender received late will not be entertained. You may witness the opening of the tender if you so desire. If a representative is deputed, he should bring a letter of authority from you.

1.2 Only one tender should be included in one envelope. The outside of the envelope should be inscribed with:-

Tender Enquiry No: **3521-2-1-49-Capt-Pur-AA**
Tender to be opened on: **19-3-2020**
Address as follows:-

Managing Director-AA
POF Wah Cantt

1.3 If envelope does not indicate reference of T.Es or received late the same may be returned un-opened.

Contd...

2. **GENERAL INSTRUCTIONS REGARDING PREPARATION OF QUOTATIONS**

- 2.1 For materials, the prices should be filled in column 5 and delivery date in column 6 of the schedule to this Tender Enquiry. The undertaking should be signed at the bottom of the Schedule which shall form the Quotation. You may use a separate sheet if necessary.
- 2.2 For Plant and Machinery, you are required to quote in two parts:-
- Part I "Technical Offer":** It should exclusively give technical details and literatures/brochures of the offered services; validity date; delivery schedule; and signed undertaking given on the schedule to this Tender Enquiry. It must not indicate price, costs etc.
- Part II "Commercial Offer":** It should indicate the commercial terms e.g. price, terms of payment, mode of payment, mode of supply.
- Each part should be placed in a separate sealed cover. The envelopes should be inscribed with Part I "Technical Quotation without Price" and Part II "Commercial Quotation with Price".
- 2.3 The quotation must remain valid for, at least 90 days from the date of opening of tenders.
- 2.4 The quotation should hold good for any reduced or enhanced quantities without notice.
- 2.5 In the event of non-acceptance of offer, intimation may be given to the Tenderers on their request.
- 2.6 Conditional offers or alternative offers are likely to be ignored.
- 2.7 Quotations should be based on:-

F.O.R. station of dispatch basis, i.e. delivered free on rail, inclusive of packing and forwarding charges. The stores will be booked under Military Credit Note, to be provided by the purchaser.

and/or

Free delivery at POF's stores at **WAH CANTT.**

- In this case Octroi duty if any, will be payable by the supplier.
- 2.8 Taxes and Duties etc. where applicable, must be shown separately, quoting references to Registration No. in cases of Sales Tax and relevant authority in the case of others. Offers without these clarifications and inclusive of Taxes and Duties may be ignored.
- 2.9 Taxes and duties levied on or after Tender opening date or on or after the date offer was signed and dispatched will be allowed to include in the offered rates.
- 2.10 "Suppliers will furnish a certificate, issued by Excise & Taxation Deptt., that he has cleared all Professional Tax payable by him" offers received without this certificate will be rejected.

Contd...

- 2.11 Suppliers will render necessary information regarding hazardous effects on environment, of the material/products supplier by them, in their quotations and shipping/dispatch documents
- 2.12 If the requisite information is not furnished on the T.E forms or offer received is not conformity with the requirement of the T.E such offer shall be ignored.

3. **INSPECTION**

- 3.1 Supplies shall be subject to the inspection and acceptance by the competent inspection authority nominated by the Purchaser, who will arrange it at his own cost. Inspection facilities such as tools, test equipment, instruments etc will, however, be provided by the Suppliers in accordance with the relevant specifications.
- 3.2 Where considered necessary by the Purchaser, stores may be obtained on Warranty / Guarantee, subject to inspection on receipt. Rejected stores will be removed and replaced with the acceptable stores by the Supplier at his own expense, within a specified time.

4. **TENDER FEE**

The tender must be accompanied by a non-refundable fee by means of a crossed postal order / pay order of **Rs.500.00** in favour of **Director-Admin POF, Wah Cantt.**

4.1 TENDER SAMPLE

Where required, offer must accompany tender sample, strictly according to the description and specification given in Tender Enquiry. Offer not accompanied by tender sample will NOT be entertained excepting the established and reputable firms who have either previously satisfactorily supplied the same or similar stores or have submitted an acceptable sample thereof against previous T.E.

5. **BID MONEY**

- 5.1 **Bid Money at the rate of 2% (for registered firms) & 5% (for un-registered firms)** of the quoted value should accompany the tender in the shape of Deposit At Call Receipt/Pay Order/Banker's Cheque, from a scheduled Bank drawn in favour of

GM-Planning-AA
POF, Wah Cantt

Tenders received without Bid Money will be rejected.

- 5.2 Bid Money of the unsuccessful tenderers will be returned as soon as the scrutiny of the tenders is completed. Bid Money of the successful tenderers will be retained until the contract is finalized. Bid Money will be forfeited in case the quotation is withdrawn before the expiry of its validity date.
- 5.3 State owned organizations are not required to provide Bid Money.

6. **ACCEPTANCE OF OFFERS**

- 6.1.1 POF may reject all bids or proposals at any time prior to the acceptance of a bid or proposal. The procuring agency shall upon request communicate to any supplier or contractor who submitted a bid or proposal, the grounds for its rejection of all bids or proposals, but is not required to justify those grounds.
- 6.1.2 POF shall incur no liability, solely by virtue of its invoking sub-rule (1.1) towards suppliers or contractors who have submitted bids or proposals.
- 6.1.3 Notice of the rejection of all bids or proposals shall be given promptly to all suppliers or contractors that submitted bids or proposals.

6.2 PERFORMANCE BOND

- (a) The successful bidders shall provide performance bond at the rate, prescribed by POF Board according to the value of contract, which should not exceed 10% of contract value in the form of Deposit At Call Receipt from a scheduled Bank; or, an un-conditional Bank Guarantee valid for 12 months (03 months extendable to 12 months in case of cloth items required by Clothing Fy.) after receipt of store in POFs on a prescribed format. The performance Bond will be in favour of CMA(POF) Wah Cantt. It will be returned on satisfactory completion of contract.
- (b) If the supplier fails to furnish the performance bond within the specified time, such failure will constitute a breach of the contract and the purchaser shall be entitled to make other arrangements for purchase of the stores at the Risk & expense of the supplier.
- 6.3 Performance Bond from State owned organizations may be waived off at the discretion of the Purchaser.

6.4 FAILURE TO SUPPLY THE STORES

All deliveries/ services must be completed by the specified date. In case of failure to deliver the stores within the scheduled time should have arisen from "Force Majeure", which the purchaser may admit as reasonable ground for further time, he will allow such additional time as he may consider to have been required by the circumstances of the case. Otherwise, he will be entitled, at his discretion, to cancel the contract; and/or claim liquidated damages upto 2% but not less than 1% of the contract price of the items and their quantities for each and every month or part of a month, beyond the specified delivery date, during which these may not be delivered, subject to a maximum of 10% of the total contract value of the particular stores which remained unsupplied either in part or in full: or, to purchase, from elsewhere, the unsupplied stores at the risk and cost of the supplier.

Contd...

6.5 PAYMENT

- (a) Payment will be made by the CMA(POF) through crossed cheques on receipt/ acceptance of stores on our prescribed bill form supported by receipt voucher on part/full supply basis.
- (b) Payment of duties/Taxes including professional tax (where applicable) must be supported by proof of having paid these to concerned Govt. Taxation Deptt.

7. **SECURITY OF INFORMATION**

The tenderer and his employees must not communicate any information relating to the sale/purchase of stores under this enquiry to any person other than the manufacturer or to any press or agent not authorized in writing by POFs to receive it.

Please return the Schedule to the Tender duly signed by the specified date, alongwith the specifications, drawings etc. if any, enclosed herewith - even if you are unable to quote.

Signature of the Supplier:

Yours faithfully,

Name: _____
 Status in the firm: _____
 Address: _____

 Place: _____
 Date: _____

(Waqas Ahmad)
Managing Director-AA
 For and on behalf of the President
 of Islamic Republic of Pakistan

PAKISTAN ORDNANCE FACTORIESSCHEDULE TO TENDER NO. 3521-2-1-49-Capt-Pur-AA, dated 12-02-2020(1) **Retrofitting / Up-gradation of CNC Machine.**

(1)	(2)	(3)	(4)	(5)		(6)
Item No.	Description with Specs etc	Unit	Qty.	Price Per Unit FOR or free delivery		Delivery Date
				In Figures	In Words	
1	Retrofitting / Up-gradation of CNC Spinner TC-65, 02 Axis CNC Turning Machine	No.	01 off			

(2) Specifications:- Enclosed as Annexure-'A & B'

(3) Special Conditions:- Enclosed as Annexure-'C'

(4) Tech. Comparison:- Enclosed as Annexure-'D'

(5) **Undertaking**

Should our offer be accepted, we hereby undertake to supply the stores/render the services contracted on the basis of Conditions of Contract embodied in Form POF-1281, and to deposit the performance bond within the prescribed time, failing which it will constitute a breach of contract, and POF will have the right to purchase the stores/services elsewhere at our risk and cost.

Place _____

Date _____

Signature of the Tender

Name

Position

Address

Income Tax G.I.R. No

**TECHNICAL SPECIFICATIONS & SCOPE OF WORK FOR
RETROFITTING / UP-GRADATION OF CNC MACHINE**

1. SCOPE OF WORK

Retrofitting / Up-gradation of CNC Spinner TC-65, 02 Axis CNC Turning Machine, Sr. No. AH-0131, Make 2002, M/s. Spinner, Turkey – Qty. 01 Off

2. CURRENT STATUS OF MACHINE VIZ-A-VIZ REQUIREMENTS

Machine status is as follows:-

Electrical / Electronics		
Sr. #	Existing System	Requirements
i.	a. Complete Set of CNC Control of (Siemens) Sinumerik 810 D, PLC, HMI Units and I/O interfacing Hardware etc. b. Supports at least 4-5 Axis and all contour operations W/LC 0.001mm accuracy	a. Replacement with latest CNC control system of reputable firm's like Syntec, GSK etc b. Supports at least 4-5 Axis and all contour operations W/LC 0.0001mm accuracy
ii.	a. Main spindle Motor AC Servo used also as Axis i.e. (C,Y Axis) b. Type: 1PH7133-2ND00-0CJ0(Siemens) c. Max 8000rpm 430v d. 30A e. 15 kW f. 46.4Hz g. 2.5Nm	To be replaced. Spindle must be (C-Y) axis a. Max 5000rpm 430v b. 30A c. 15 kW d. 46.4Hz e. 2.5Nm
iii.	a. X-axis AC Servo Motor b. Type: 1FK 6063-6AF71-1FH0(Siemens) c. Min 5.4 Nm 276V d. Max 3000 rpm (With brake).	To be replaced with AC Servo Motors of appropriate power ratings a. Min 5.4 Nm 276V b. Max 3000 rpm (With brake)
iv.	a. Z-axis AC Servo Motor b. Type: 1FK6063-6AF71-3EG0. c. Min 5.4 Nm d. 276v e. Max 5000 rpm.	To be replaced with AC Servo Motors of appropriate power ratings a. Min 5.4 Nm b. 276v c. Max 5000 rpm.
v.	a. Driven Tool AC Servo Motor b. Type: 1FT 6064-6AK71-4AA2.(Siemens) c. Min 2.1 Nm d. 294v e. Max 6000 rpm.	To be replaced with AC Servo Motors of appropriate power ratings a. Min 2.1 Nm b. 294v c. Max 6000 rpm.
vi.	Encoders Compatible to the Motors (Absolute types)	To be replaced with compatible encoders. All NC controlled axes must have separate compatible encoders.
vii.	Servo Drive system for all the Motors.	To be replaced with AC servo motors.
viii.	Hydraulic bar loader	To be integrated with control system
ix.	Cable Harnesses & other Electrical accessories	To be replaced as per requirement of the control & applicable safety standards.

Contd...

3. GENERAL CHARACTERISTICS OF CONTROL

- i. The control should be cost effective and environment friendly.
- ii. System should be safe to handle spikes and surges (Transient).
- iii. System must include line filter & line reactor.
- iv. System must include safety integrated features.
- v. All functions/movements of axis and Bar Loader etc should be fully automatic according to loaded programme.
- vi. System must include refrigerant based hydraulic oil cooling unit as per machine requirement.

4. SITE SURVEY

The bidder may visit site for inspection of Machines prior to submission of quotation.

5. DOCUMENTATION

OEM will provide following documents to POF:-

- i. 04 x Sets of Operation, Maintenance & Service Manual in English version.
- ii. 04 x Sets of Complete Electrical Wiring Drawings.
- iii. In case of alteration / replacement in mechanical parts / unit, firm will ensure provisioning of updated drawings.

6. INPUT & SUPPORT MATERIALS

The input material comprises of Mild Steel, Aluminum, Brass & Copper for manufacturing of components will be provided by POF.

7. SPARES

- i. It shall be guaranteed that spares shall be available for at least 10 years after successful commissioning of machine.
- ii. Spare parts for 4000 hours would be provided. The following spare must be made part of delivery against spares :-
 - a. Servo Motors (01 x Complete Set)
 - b. Relays (10% of installed relays)
 - c. Circuit Breakers (01 against each type)
 - d. Control Boards (01 x Complete Set)
 - e. Backup battery for CNC control to store programme backup.

8. CLIMATIC CONDITIONS

The available climatic conditions for functioning of the machine are:-

- i. Temperature:
 - a. Winter = - 3⁰ to + 20⁰ C
 - b. Summer = 30⁰ to 50⁰ C
- ii. Relative Humidity = 25 to 90%
- iii. Earthquake Value = 8.5 on Richter scale

Contd...

9. UTILITIES

The available utilities on site for functioning of the machine are:-

- i. Electricity :
 - a. Electricity 400 ± 5% Volts, 50 Hz, Three Phase
 - b. Electricity 220 ± 5% Volts, 50 Hz, Single PhaseIn case of surge, the variation may go upto 10%
- ii. Compressed air supply 6 Bar

10. TECHNICAL SUPPORT & TRAINING

- i. The supplier shall confirm provisioning of technical support for atleast 10 years as and when required.
- ii. The supplier shall provide licensed copy of software of control system of CNC in the form of CD or USB.
- iii. The supplier shall provide upto date knowhow of latest advancement in the related technology for improvement in the machine operation.
- iv. During working at purchaser's premises, supplier's engineers shall train the concerned production & maintenance personnel for operation, maintenance & safe use of equipment.

11. STRIP DOWN

- i. Supplier will carry out strip down of machine at purchaser's premises.
- ii. Inspection of parts will be carried out after cleaning.
- iii. Before machine strip down, all geometric & electric parameters of the machine will be noted for reference & record.
- iv. The supplier will identify the scope of work for part / assemblies required to be carried out at firm's premises / trade. Execution of such work will be the responsibility of supplier.

12. INSTALLATION & COMMISSIONING

- i. Installation & commissioning is the responsibility of supplier.
- ii. POF will provide services and manpower to help during installation & commissioning
- iii. All safety risks associated with installation & commissioning are the responsibility of supplier.
- iv. Needed material for installation & commissioning would be managed by the supplier.
- v. The supplier will provide information regarding total man-weeks of his engineers / technicians required for installation, commissioning and trial production run of the machine. All expenses, including boarding & lodging, air travel and daily allowances of the engineers/ technicians are to be borne by the supplier. However Local transportation shall be arranged by the purchaser.
- vi. The supplier will indicate the time schedule for the completion of whole project.

Contd...

DIMENSIONS IN MM
THIRD ANGLE PROJECTION

Annexure-'B'
Page 1 of 1

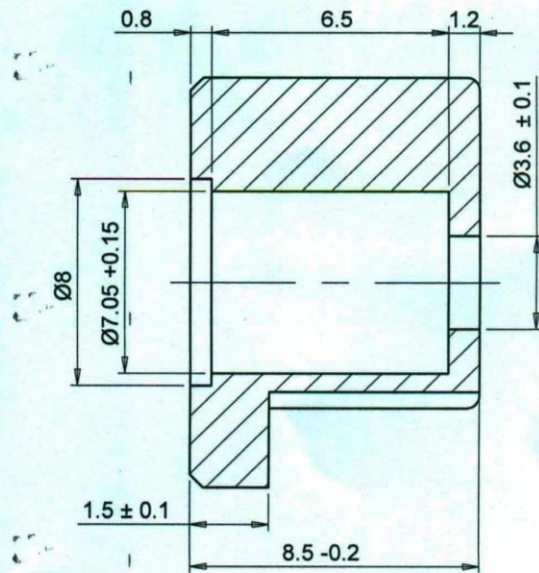
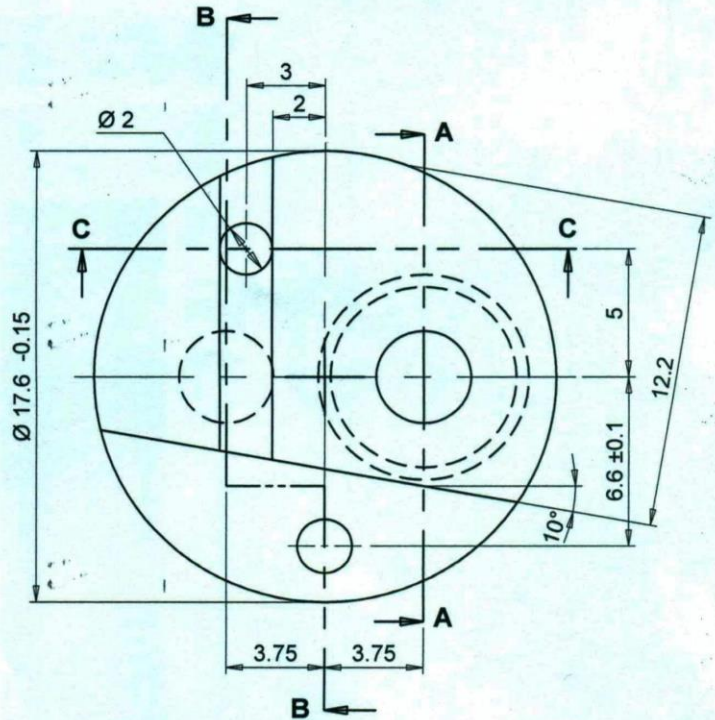
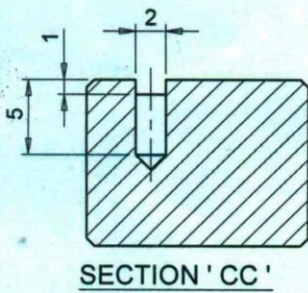
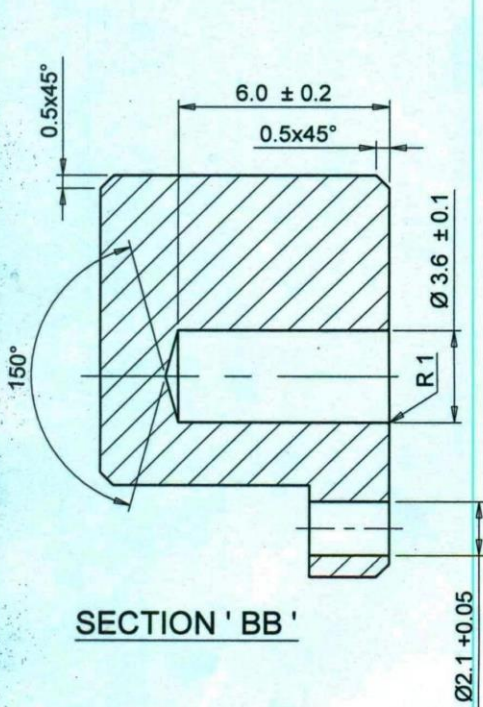

MATERIAL :
BRASS ROD TO SPEC. BS-2874 CZ 121 3 Pb
PROTECTION :
PASSIVATE TO SPEC. L 10205 B

ARTILLARY AMMO. FY.
PAKISTAN ORDNANCE FACTORIES
WAH CANTT - PAKISTAN

DRG. No.
SK / COM - 7609
DATE:- 23 - 11 - 2019

PAKISTAN ORDNANCE FACTORIES

Schedule to Tender No. 3521-2-1-49-Capt-Pur-AA, dated 12-02-2020

1. **Special Conditions**

- i. Single Stage-Two envelope bidding procedure will be adopted. Each bid shall comprise two separate envelopes containing: financial proposal and technical proposal. Financial proposals of technically qualified firms would be opened only, after technical scrutiny. Remaining commercial offers would be returned unopened.
- ii. **For the sake of technical understanding firms are requested to furnish their request for visiting and witnessing the machine requiring retrofitting within a week of floating this tender, so that formal approval of visit be obtained from competent authority. The visit request must contain particulars of individual, including full name and CNIC No. This provision is being allowed to assist the firms in developing complete understanding of scope of work and submitting relevant quotations afterwards.**
- iii. Offer should be in local currency on FOR Wah Cantt basis.
- iv. Any quantity of store, if found defective functionally, will essentially be replaced by the supplier free of cost under his own arrangement.
- v. The store must be protected adequately and appropriately against damages from environmental effects, water or other substances during journey/transportation to withstand the rough handling involved in transit & provide preservation of store while held in storage by the consignee
- vi. After placing of contract, accepted copies of the contract duly signed & stamped must be provided within 05 days.
- vii. Payment will be released upon final acceptance and trial run of machine (as stated under Clause No. 13 of Annexure-'A').

2. **Technical Scrutiny Criteria**

The scope of work is typical one and only those firms can undertake the job who have relevant experience of dealing (Up-gradation/Retrofitting, services) with CNC Machine, therefore other than potential bidders (having experience of dealing with (CNC Machine) shall not be technically accepted.

- 2.1 Participants/Bidders are obligatory to forward necessary credentials of their firm showing/elaborating details of their business with Govt / Semi-Govt & Public Sector organization/departments of Pakistan alongwith their quotation.

NOTE:- A. TENDERS ACCOMPANYING BID MONEY LESS THAN 2% (FOR REGISTERED FIRMS) & LESS THAN 5% (FOR UN-REGISTERED FIRMS) WILL BE REJECTED.

Contd...

- B. TENDERS ACCOMPANYING NON-REFUNDABLE TENDER FEE LESS THAN RS.500.00 WILL BE REJECTED.
- C. ONLY THOSE SUPPLIERS, WHO ARE ON ACTIVE TAXPAYER LIST (ATL) OF FBR, ARE ELIGIBLE TO SUPPLY GOODS/SERVICES TO POFs.
- D. THE PAYMENT TO THE REGISTERED PERSONS WILL BE LINKED WITH THE ACTIVE TAXPAYER STATUS OF THE SUPPLIERS AS PER FBR DATABASE. IF ANY REGISTERED SUPPLIER IS NOT IN ATL HIS PAYMENT WILL BE STOPPED TILL HE FILES HIS MANDATORY RETURNS AND APPEARS ON ATL OF FBR.

Signature of the Supplier:

Name: _____

Status in the firm: _____

Address: _____

Place: _____

Date: _____

TECHNICAL COMPARISON
(TO BE FILLED BY SUPPLIER)

SR. #	TENDER SPECIFICATIONS	OFFERED SPECIFICATIONS WITH REFERENCE TO PAGE NO. OF QUOTATION