



Government of Pakistan
PAKISTAN ORDNANCE FACTORIES
TENDER ENQUIRY

To

Dear Sirs,

Reference: **TENDER ENQUIRY NO. 2500-GEN-FP-EDM-P-SAA-CAPT, Dt: 20-03-2019**

You are requested to submit sealed quotations for the item (s) noted on the Schedule to the Tender. Please note the following instructions for filling the tender:-

1 **SUBMISSION OF TENDER.**

1.1 Tenders will be opened at 1200 hours on **06-05-2019** and must reach at **Bid Centre adjacent to Rabita Hall Wah Cantt** at least half an hour earlier than the opening time. The tender received late will not be entertained. You may witness the opening of the tender if you so desired. If a representative is deputed, he should bring a letter of authority of principal/OEM.

1.2 Only one tender should be included in one envelope. The outside of the envelope should be inscribed with:-

Tender Enquiry No: **2500-GEN-FP--EDM-P-SAA-CAPT**
Tender to be opened on: **06-05-2019**

Address as follows:-

MANAGING DIRECTOR SAA & BM,
Pakistan Ordnance Factories,
Wah Cantt, Pakistan
Fax No. 051-9314100 & 051 9271400
Email: mdsaa@pof.gov.pk

1.3 If envelope do not indicate reference of T.Es or received late, the same may be returned unopened:-

2. **EVALUTION CRITERIA.**

All the technical proposals will be evaluated/scrutinized initially and commercial proposals of only those bidders will be opened who will be technically prequalified/accepted. Accordingly, Order/Contract will be placed on the lowest evaluated/technically qualified bidder.

3. **GENERAL INSTRUCTIONS REGARDING PREPARATION OF QUOTATIONS.**

3.1 For Plant and Machinery, you are required to quote in two parts:-

Part I “Technical Offer”: It should exclusively give technical details and literature/ brochures of the offered plant/machinery and equipment; validity date; delivery schedule; and signed undertaking given on the schedule to this Tender Enquiry. It must not indicate price, costs etc.

Part II “Commercial Offer”: It should indicate the commercial terms e.g. price, terms of payment, mode of payment, mode of supply.

Each part should be placed in a separate sealed cover. The envelope should be inscribed with: Part I “Technical Quotation without Price” and Part II “Commercial Quotation with Price”.

3.2 The quotation must remain valid for, at least 90 days from the date of opening of tenders.

3.3 The quotation should hold good for any reduced or enhanced quantities without notice.

3.4 Conditional offers or alternative offers are likely to be ignored.

3.5 Quotations should be based on FOB. The consignment will be shipped through Pakistan National Shipping Corporation (PNSC). In case there is no PNSC service in the country of Supplier, please quote on C&F basis. The freight should be indicated separately. Insurance premium should not be included in the quoted price. However, where insurance is considered necessary, advice to that effect should be given in the quotation.

3.6 Submission of the offer through an agent in Pakistan should be avoided. In case it is considered inevitable, the original proforma invoice must invariably accompany the agent’s quotation from the principals/manufacturers.

3.7 Country of origin and port of shipment to be stated.

3.8 Declaration form as per **Annex-‘B’** is required to be submitted by the supplier.

3.9 The offer of the principal must clearly indicate whether the rate quoted is inclusive of agent’s commission, and if inclusive rate of commission included be specified.

3.10 Suppliers will render necessary information regarding hazardous effects on environment of materials/products supplied by them, in their quotations and shipping/dispatch documents.

3.11 If the requisite information is not furnished on the T.E form or offer received is not in conformity with the requirement of T.E such offer shall be ignored.

4 **INSPECTION & TRAINING.**

- 4.1 Supplies shall be subject to the Pre Shipment Inspection (PSI) and acceptance by the competent Inspection authority nominated by the Purchaser. Expenses of POFs personnel, **03** men for **07** working days in the field of operation and maintenance of the plant at Supplier's and its sub contractor's premises and other relevant production facilities as well, including boarding, lodging, return air ticket, inland travel and daily allowance will be borne by the Supplier. Inspection facilities such as tools, test equipment, instruments etc. will be provided by the Suppliers in accordance with the relevant specifications.
- 4.2 Where considered necessary by the Purchaser, stores may be obtained on Warranty/Guarantee, subject to inspection on receipt. Rejected stores will be removed and replaced with the acceptable stores by the Supplier at his own expense, within a specified time. The supplier will render warranty/guarantee certificate as per **Annex-‘C’**.

5 **ACCEPTANCE OF OFFERS.**

The right to accept or reject any offer in full or in part, is hereby reserved.

6 **PERFORMANCE BOND.**

- a. The successful bidder will provide Performance Bond as per **Annex-‘D’** at the rate of 10% of F.O.B (In case of C&F 10% of total C&F value) value of the contract in favour of CMA (POF) Wah Cantt. The Performance Bond will be furnished in the form of an unconditioned bank guarantee on prescribed proforma covered by any scheduled bank in Pakistan. The Performance Bond shall be furnished within 45 days from the date of opening of Letter of Credit. It shall be valid for a period of **24 months** after successful installation/commissioning and final acceptance of Equipment. If the Performance Bond is not furnished within a/m prescribed time, the Purchaser reserves the right to cancel the contract and has the right of risk purchase action.
- b. No Performance Bond will be required if the total FOB value of the contract is less than US\$ 50,000 and contract is placed directly on the foreign Supplier.

7 FAILURE TO SUPPLY THE STORES

All deliveries must be completed by the specified date. If the failure to deliver the stores within the scheduled time should have arisen from "Force Majeure", which the Purchaser may admit as reasonable ground for further time, he will allow such additional time as he may consider to have been required by the circumstances of the case. Otherwise, he will be entitled, at his discretion, to cancel the contract; and/or, claim liquidated damages up to 2% but not less than 1% of the contract price of the items and their quantities for each and every month or part of a month, beyond the specified delivery date, during which these may not be delivered, subject to a maximum of 10% of the total contract value; or, to purchase from elsewhere, the unsupplied stores at the risk and cost of the Supplier.

8 PAYMENT.

- i. Payment will be made by means of irrevocable letter of credit. **80% payment** will be released on submission of dispatch documents along with pre-delivery inspection/acceptance certificate from the purchaser while balance **20% payment** will be released on receipt of plant & machinery at 'POF' Wah Cantt and after satisfactory completion of specified trial run/FAT of the machine (manufacturing 05 components according to each drawing attached as Annex "A-E") at purchaser's premises against the acceptance certificate issued by the purchaser.
- ii. All Bank charges incurred inside Pakistan in connection with the establishment of L.C. will be borne by the Purchaser. Whereas all Bank charges for obtaining payment outside Pakistan including charges for confirmation of L.C. by the advising Bank/Foreign Bank will be borne by the Supplier.

9 ARBITRATION.

All matters of dispute or difference, except regarding rejection of stores by the inspector and/or cancellation of contract by the purchaser arising out of this agreement between the parties hereto, the settlement of which is not otherwise specially provided for in this agreement, shall be referred for adjudication to two arbitrators, one to be named by each party, who before entering upon the reference shall appoint an umpire by mutual agreements, and if they do not agree a judge of superior court shall appoint the umpire, the arbitration proceedings shall be held in Pakistan under the Pakistan law. The arbitration awards shall be un-spoken.

10 **SECURITY OF INFORMATION.**

The tenderers and his employees must not communicate any information relating to the sale/ purchase of stores under this enquiry to any person other than the manufacturer or to any press or agent not authorized in writing by POF to receive it. Please return the Schedule to the Tender duly signed by the specified date, along with the specifications, drawings etc, if any, enclosed herewith – even if you are unable to quote.

11 **WARNING:**

In case the firm abstain from making offers or fail to return/acknowledge the tender form by the specified date or three consecutive occasions, no further tender enquiry may be issued to them and their names should be liable to be removed from the approved list.

NOTE:

Offers/bids through **Email & Fax** are not acceptable. The offers/bids must be submitted on firm's original letter head pad through **Mail/Courier**.

Yours faithfully,

(MUNAWAR AHMED)
MANAGING DIRECTOR
SAA & BM POF WAH CANTT
(PAKISTAN)

Contact Info:

Exchange.	i. 051-9055-5000	Direct:	051-9055-21071
	ii. 051-4514000.		
Fax:	i. 051-9271400	Email:	mdsaa@pof.gov.pk
	ii. 051-9314100		

PAKISTAN ORDNANCE FACTORIES

SCHEDULE TO TENDER NO. **2500-GEN-FP-EDM-P-SAA-CAPT**, Dated: **20-03-2019**

Due on **06-05-2019**.

(1) For Plant & Machinery:

**CNC EDM (Electrical Discharge Machining)
DIE SINKING MACHINE.
(Qty. 02 Nos)**

(2) Specifications:- As per attached 'Annex-A'

(3) Special Conditions:

Reputable OEMs/manufacturers can participate and required to provide the following information:-

- i. Proof of being an OEM/ OEM's representative with profile/brochure.
- ii. List of similar equipment supplied in the past, with references.
- iii. Initially, only the envelope marked "Technical Proposal" shall be opened.
- iv. Purchaser reserve the right to take risk purchase action if any firm refuses to supply the required equipment after submission of their quotation/proposals.
- v. Only those OEMs should participate in the tender who can arrange Export license from their respective Govt.
- vi. The under mentioned under taking must be signed by the authorized signatory of OEM.

(4) Undertaking:

Should our offer be accepted, we hereby undertake to supply the stores/render the services contracted on the basis of Conditions of Contract embodied in Form POF 1282, and to deposit the 10% performance bond within the prescribed time, failing which it will constitute a breach of contract, and POF will have the right to purchase the stores/services elsewhere at our risk and cost.

Place _____

Signature of the Tenderer _____

Date _____

Name _____

Position _____

Address _____

Income Tax G.I.R. No. _____

TECHNICAL SPECIFICATION OF MACHINERY

Nomenclature of Machinery With
Quantity

CNC EDM (ELECTRICAL DISCHARGE MACHINE)
DIE SINKING MACHINE (02 Nos)

1. CO-ORDINATE TABLE

i.	Max. Work Piece L x W x H	:	600 x 400 x 250 mm
ii.	Axis travel x, y, z	:	300 x 250 x 250mm
lii	Max. Work Piece weight	:	200 kg (approx.)
iv.	Max. distance work table to spindle	:	540 mm
v.	C - axis	:	Integrated
vi.	Work current	:	> 100 A
vii.	Best roughness	:	Ra 0.1 µm
viii.	Control servo axis	:	X,Y,Z, C axis
ix.	Tank Capacity (Cutting Oil)	:	350 ltrs. Approx

2. EQUIPMENT / ACCESSORIES

Standard Equipments

- a) Clamping Chuck for job holding
- b) Electrode holder
- c) Working Light
- d) Work Modules / software, LAN interface USB port, and accessories with machine.
- e) A/Cs should be installed in panel/system (where necessary).

Spare Parts for 02 years including:

- a) Provision of mech. spares list.
- b) Provision of electrical spares list.
- c) Provision of electronic spares list.

NOTE:- spare parts list must be flexible so that purchaser can decide actual quantity according to annual requirement of the machines.

3. DOCUMENTS

- a) Three sets for technical literature
- b) Provision of machine parameters.
- c) Program of machine soft and hard copies.
- d) Dedicated programmer in case of PLC installed.
- e) Manual for machine programming.
- f) Manual for calibration procedures.

4. SAFETY

All equipment should be equipped / provided with all safety gadgets / accessories according to latest safety standards including standards:

- i. The Machines should be environment friendly.
- ii. System should be safe to handle spikes and surges.(Transient)

5. TOOLING & SPARES:

It shall be guaranteed that spares shall be available for at least 15 years after M/C handed over and successfully commissioned.

6. CLIMATIC CONDITIONS:

- i. **Temperature:** = **-1 to 50 0C**
- ii. Relative Humidity = Max. 90%
- iii. Earthquake Value = Max. 8.5 on Richter scale

7. UTILITIES AVAILABLE AT SITE:

- i. Electricity 400 ± 5% Volts, 50 Hz, Three Phase.
- ii. Electricity 220 ± 5% Volts, 50 Hz, single Phase.
- iii. Compressed air pressure = 6 bar (Max)

8. PRE-SHIPMENT INSPECTION & TRAINING:

- i. Supplies shall be subject to the Pre Shipment Inspection (PSI) and acceptance by the competent Inspection authority nominated by the Purchaser. Training expenses of POF's personnel, **03** men for **07** working days in the field of operation and maintenance of the plant at Supplier's and its sub contractor's premises and other relevant production facilities including boarding, lodging, return air tickets, inland travel and daily allowance will be borne by the Supplier. Inspection facilities such as tools, test equipment, instruments etc. will be provided by the Suppliers in accordance with the relevant specifications.
- ii. The supplier shall inform the purchaser when the equipment/machines are ready for dispatch. The equipment /machines & equipment will be subjected to pre delivery inspection and trials at supplier's premises in the presence of rep(s) of purchaser. The machine should be capable for proper manufacturing of highly precise Tools, Equipments gauges and Dies (Tungsten Carbide material), as shown in fig a,b,c. (Attached as Annex –E).
- iii. For PSI, blanks of dies with machining allowance of 0.5mm approx. alongwith blank material of copper electrodes will be provided by the purchaser. However, transportation of the blank of dies, copper electrodes and gauges from purchaser premises to supplier premises will be arranged/borne by the supplier. The components/webbing produced during Pre-shipment trials will be returned by weight to the purchaser with the equipment/machines.
- iv. The m/c will be dispatched only after the supplier's receives the pre-delivery trials acceptance certificate issued by the purchaser certifying that the equipment has qualified the satisfactory working performance trial.
- v. Where considered necessary by the purchaser, the stores may be obtained on warranty / Guarantee, subject to inspection on receipt. Rejected stores will be replaced with the acceptable stores by the Supplier at his own expense, within a specified time. The supplier will render warranty guarantee certificate.
- vi. During stay on site at purchaser's works, supplier's engineers shall train the concerned production and maintenance personals for satisfactory & safe use of equipment.

9. TECHNICAL SUPPORT:

The supplier shall confirm that after handing over of the m/c there shall be technical support at least 15 years as & when required by the purchaser. In addition the purchaser shall be kept informed regarding latest advancement in the related technology for further improvement in the production and operation of the equipment.

10. TERMS OF DELIVERY

- i. The delivery will be on FOB/C & F Karachi sea port or Islamabad Airport basis. In case of C & F, Freight should be mentioned separately.
- ii. Partial shipment within the delivery period will be permitted.
- ii. Machine parts would be lettered in English and / or internationally recognized symbols.

11. INSTALLATION, COMMISSIONING AND TRIAL PRODUCTION RUN:

- i. The equipment/machines shall be installed by the purchaser under the supervision of the supplier's engineers and technicians.
- ii. The equipment/machines shall be commissioned and trial production of the equipment/machines shall be carried out by supplier's engineers. Purchaser shall provide required number of operators and technicians for the commissioning and trial production of the equipment/machines.
- iii. The supplier is to indicate the total man-weeks of his engineers / technicians required for installation, commissioning and trial production of the equipment/machines. Terms and conditions are to be stated clearly. All expenses, including boarding & lodging, air travel and daily allowances of the engineers / technicians will be borne by the supplier. Local transportation shall be arranged by the purchaser.
- iv. The supplier is to indicate the time schedule for the completion of whole project.
- v. The oil and process lubricants (if required) shall be supplied by the supplier free of cost for 01 year use/requirement of the machines.

12. FINAL ACCEPTANCE

- i. Final acceptance test will be performed at purchaser premises. This test will be carried out with the technical assistance of the supplier and will comprise successful/ satisfactory working performance with the manufacturing of dies, punches and gauges.
- ii. If the specified production of the equipment/machines is not achieved within stipulated period after the effective date of contract, the supplier experts will stay, at supplier cost till the production has been achieved provided such delays are attributable to supplier. Supplier men should stay for 01 months after successful trial run to look after / handle the plant problems at supplier's expense. The tooling and process lubricants consumed during trial production run will be borne by the supplier.
- iii. Delay plenty will also be imposed @ 1 % per month of contracted value for the delayed period of achievement of production run of the equipment/machines beyond the schedule date of final acceptance and will be deducted from balance 20% payment connected with production run.

13. WARRANTY GUARANTEE:

- i. The equipment/machines and accessories shall be accepted on Supplier's Warranty / Guarantee with regard to quality and quantity subject to these being technically checked/tested and accounted for on arrival at Consignee's warehouse in presence of supplier's rep (if desired by supplier) at their cost. The supplier shall render Warranty / Guarantee certificate in duplicate to the Purchaser on the enclosed Proforma attached as annexure 'C' as soon as stores have been dispatched/delivered. This Warranty / Guarantee shall be binding on the Supplier for a period of **24 months** reckoning from the date of commissioning of the equipment/machines.
- ii. In case the stores on checking / test after receipt at Consignee's warehouse are found not conforming strictly to the relevant specification and other particulars are found damaged during transit, the Supplier shall Immediately replace the rejected/damaged stores by acceptable stores, free of cost, and without any obligation to the Purchaser. Rejected / damaged stores shall be disposed off by the Supplier under his own arrangements.
- iii. The supplier shall warrant the good quality of all equipment supplied against all defects or failures due to faulty design, material, or workmanship.
- iv. The supplier shall also provide Guarantee for meeting the requisite quality and quantity of products. In case of any deficiency in term of quality or quantity of products, all related expenditure to fulfill commitment shall be borne by the supplier.

DECLARATION

_____ [the Seller/Supplier] hereby declares its intention not to obtain or induce the procurement of any contract, right, interest, privilege or other obligation or benefit from Government of Pakistan or any administrative subdivision or agency thereof or any other entity owned or controlled by it (GoP) through any corrupt business practice.

Without limiting the generality of the foregoing, [the Seller/Supplier] represents and warrants that it has fully declared the brokerage, commission, fees etc. paid or payable to anyone and not given or agreed to give and shall not give or agree to give to anyone within or outside Pakistan either directly or indirectly through any natural or juridical person, including its affiliate, agent, associate, broker, consultant, director, promoter, shareholder, sponsor or subsidiary, any commission, gratification, bribe, finder’s fee or kickback, whether described as consultation fee or otherwise, with the object of obtaining or inducing the procurement of a contract, right, interest, privilege or other obligation or benefit in whatsoever form from GoP, except that which has been expressly declared pursuant hereto.

[The Seller/Supplier] certifies that it has made and will make full disclosure of all agreements and arrangements with all persons in respect of or related to the transaction with GoP and has not taken any action or will not take any action to circumvent the above declaration, representation or warranty.

[The Seller/Supplier] accepts full responsibility and strict liability for making any false declaration, not making full disclosure, misrepresenting facts or taking any action likely to defeat the purpose of this declaration, representation and warranty. It agrees that any contract, right, interest, privilege or other obligation or benefit obtained or procured as aforesaid shall, without prejudice to any other rights and remedies available to GoP under any law, contract or other instrument, be voidable at the option of GoP.

Notwithstanding any rights and remedies exercised by GoP in this regard, [the Seller/Supplier] agrees to indemnify GoP for any loss or damage incurred by it on account of its corrupt business practices and further pay compensation to GoP in any amount equivalent to ten times the sum of any commission, gratification, bribe, finder’s fee or kickback given by [the Seller/Supplier] as aforesaid for the purpose of obtaining or inducing the procurement of any contract, right, interest, privilege or other obligation or benefit in whatsoever form from GoP.

WARRANTY / GUARANTEE CERTIFICATE

Firm'sName _____

Contract No. _____ DATE _____

1. We hereby guarantee that the goods supplied against the above contract are in all respect in accordance with the relevant specifications and terms of the contract and that the materials used, whether or not of our manufacture are in accordance with the latest approved standard specifications complete, are of good workmanship/quality throughout, and that we shall replace free of cost, every article or part thereof which before use or in use, shall be found defective, or not within the limits and tolerance of specification requirements, or in any way not in accordance with the terms of the contract.

2. In case of our failure to replace the defective stores free of cost within the period specified by the Purchaser we will refund the relevant cost.

3. The Warranty / Guarantee will remain valid for **24 months** after the receipt of machinery by the consignee and Successful installation/commissioning of the equipment/machinery.

Signature _____

Name _____

Status in the Firm _____

Dated _____

ANNEXURE – “D”

**BANK GUARANTEE FOR PERFORMANCE ON JUDICIAL STAMP PAPER
OF RS. 100/- OR AS SUITABLE TO THE AMOUNT OF B.G.**

- i) Contract No. _____ date _____
- ii) Name of Firm/Contractor _____
- iii) Address of Firm/Contractor _____
- iv) Name of Guarantor _____
- v) Address of Guarantor _____
- vi) Amount of Guarantee Rs. /F.E _____
(_____)
(in words)
- vii) Date of Expiry of Guarantee _____

To: The President of the Islamic Republic of Pakistan through the Controller of
Military Accounts (CMA), Wah Cantt.

Sir,

1. Whereas your goodself have entered into Contract No. _____

dated: _____ with Messrs _____

(Full Name and Address)

hereinafter referred to as our customer and that one of the conditions of the Contract is the submission of unconditional Bank Guarantee by our customer to your goodself for a sum of Rs. _____ Rupees/FE (as applicable) _____

2. In compliance with this stipulation of the contract, we hereby agree and undertake as under:-

a. To pay to you unconditionally on demand and/or without any reference to our Customer an amount not exceeding the sum of Rs. _____

(Rupees or F. E (as applicable) _____) as would be mentioned in your written Demand Notice.

b. To keep this Guarantee in force till _____

- c. That the validity of this Bank Guarantee shall be kept one clear year a head of the original/extended delivery period or the warrantee of the stores which so ever is later in duration on receipt of information from our Customer i.e. M/s _____ or from your office. Claim, if any must be duly received by us on or before this day. Our liability under this Bank Guarantee shall cease on the closing of banking hours on the last date of the validity of this Bank Guarantee. Claim received thereafter shall not be entertained by us whether you suffer a loss or not. On receipt of payment under this guarantee, this documents i.e. Bank Guarantee must be clearly cancelled, discharged and returned to us.
- d. That we shall inform your office regarding termination of the validity of this Bank Guarantee one clear month before the actual expiry date of this Guarantee.
- e. That with the consent of our customer you may amend/alter any term/clause of the contract or add/delete any term/clause to/from this contract without making any reference to us. We do not reserve any right to receive any such amendment / alternation or addition/deletion provided such like actions do not increase our monetary liability under this Bank Guarantee which shall be limited only to Rs. _____ Rupees _____)
- f. That the Bank Guarantee herein before given shall not be affected by any change in the constitution of the Bank or Customer/Seller or Vendor.
- g. That this is an unconditional Bank Guarantee, which shall be encashed on sight on presentation without any reference to our Customer/Seller or Vendor.

GUARANTOR

Dated: _____

Bank Seal and Signatures

Fig -a

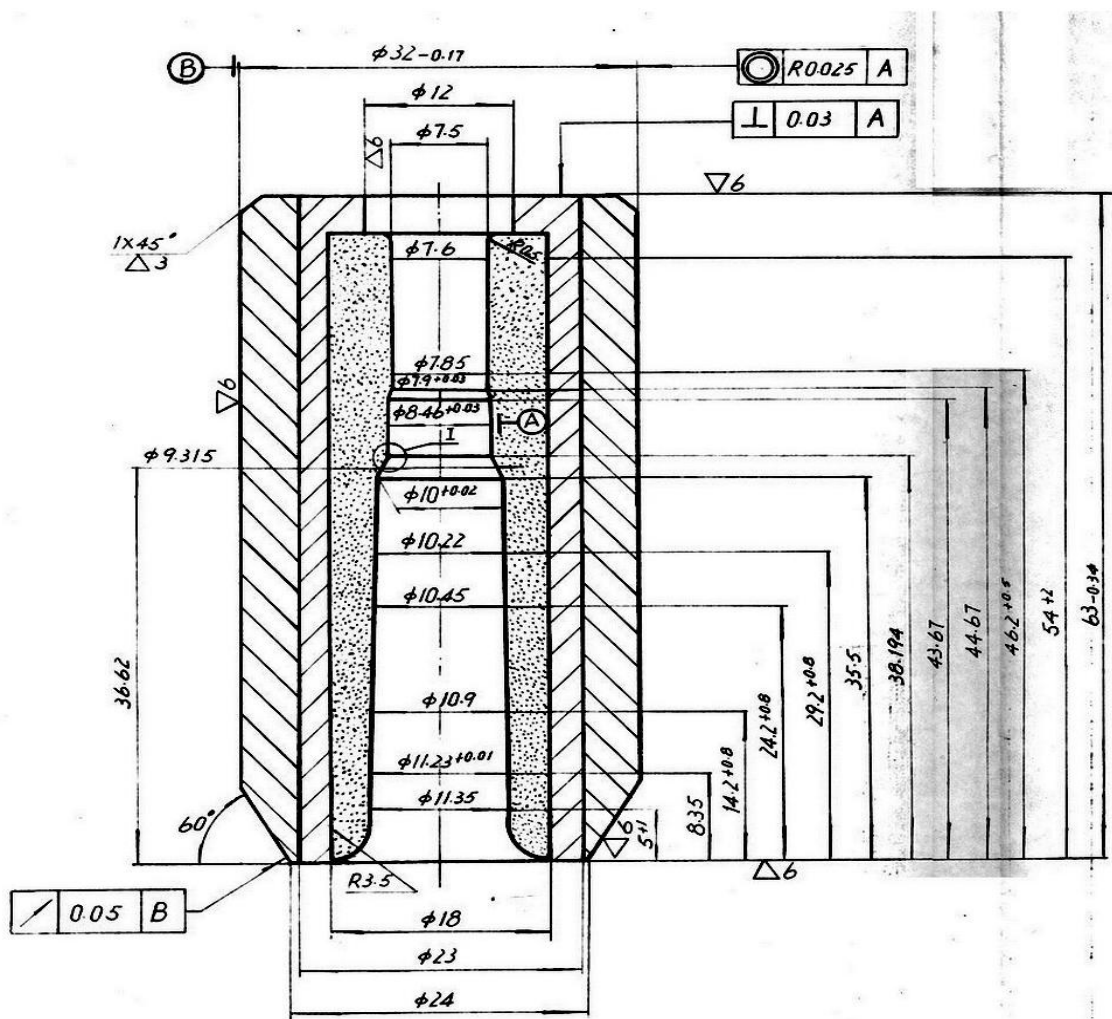

Fig -b

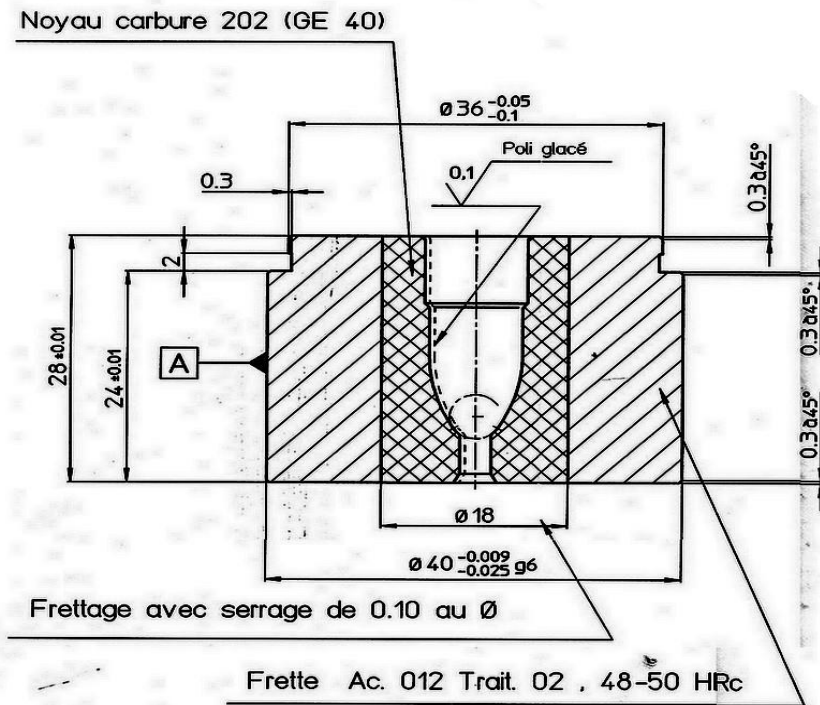
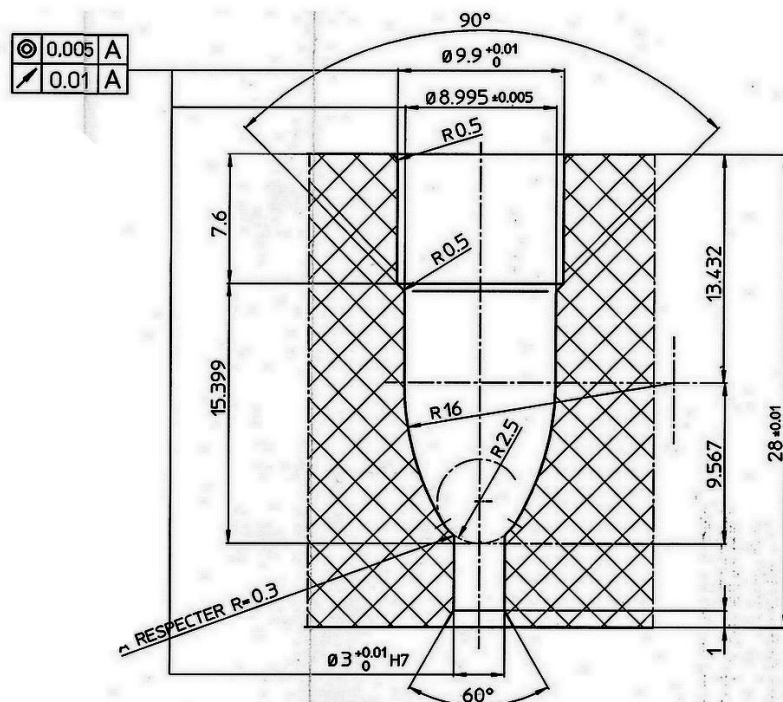

Fig c



DOMESTIC AND FOREIGN SCHEDULED COMMERCIAL BANKS

Being regulated by State Bank of Pakistan.

I. NATIONALISED SCHEDULED BANKS

1. First Women Bank Limited.
2. Habib Bank Limited.
3. National Bank Limited.

II. DE-NATIONALISED SCHEDULED BANKS

4. Allied Bank of Pakistan Limited.
5. Muslim Commercial Bank Limited.
6. United Bank Limited.

III. SPECIALIZED SCHEDULED BANKS

7. Zari Taraqati Bank Limited.
8. Industrial Development Bank of Pakistan
9. Punjab Provincial Co-Operative Bank Limited.

IV. PRIVATE SCHEDULED BANKS

10. Askari Commercial Bank Limited.
11. Bank Al-Falah Limited.
12. Bolan Bank Limited.
13. Bank Al-Habib Limited.
14. Mashreq Bank Pakistan Limited.
15. Meezan Bank Limited
16. Faysal Bank Limited
17. KASB Bank Limited
18. Metropolitan Bank Limited
19. NDLC-IFIC Bank Limited
20. Prime Commercial Bank Limited
21. PICIC Commercial Bank Limited
22. Saudi-Pak Commercial Bank Limited
23. Soneri Bank Limited
24. Union Bank Limited

V. PROVINCIAL BANKS (NOW SCHEDULED BANKS)

25. The Bank of Khyber
26. The Bank of Punjab

VI. FOREIGN BANKS

27. ABN Amro Bank N. V.
28. Al-Baraka Islamic Bank B.S.C. (E.C).
29. American Express Bank Limited
30. Bank of Tokyo Mitsubishi Limited.
31. Bank of Ceylon
32. Credit Agricole Indosuez (The Globe French Bank)
33. Citibank N.A.
34. Deutsche Bank AG.
35. Doha Bank
36. Habib Bank AG Zurich.l
37. Hong Kong & Shanghai Bank Corporation Limited.
38. Oman International Bank S.O.A.G.
39. Rupali Bank Limited.
40. Standard Chartered Bank.