



Government of Pakistan
PAKISTAN ORDNANCE FACTORIES
TENDER ENQUIRY

To

M/s .

Dear Sirs,

Reference : TENDER ENQUIRY NO. 0082/EXP/LP/48

DATED 02-AUG-18

You are requested to submit quotations for the item(s) noted in the Schedule to the Tender. Offer should be sent duly sealed in an envelope. Please note the following instructions for filling the tender:-

1. SUBMISSION OF TENDER

- 1.1 Tenders will be opened at 1000 hours on 30-AUG-18 and must reach at below mentioned address before 30 Minutes of opening time. The tender received late will not be entertained. You may witness the opening of the tender if you so desire. If a representative is deputed, he should bring a letter of authority from you.
- 1.2 Only one tender should be included in one envelope. The outside of the envelope should be inscribed with:-

Tender Enquiry No: 0082/EXP/LP/48

Tender to be opened on: 30-AUG-18

Address as follows:-

BID CENTER, CR SECTION, C-04 BUILDING, POF WAH CANTT

TELE: 0092-51-9055-29216

FAX: 0092-51-9271400

- 1.3 If envelope does not indicate reference of T.E. or received late the same may be returned un-opened.
- 1.4 Tender "By Hand" can be delivered at Bid Center, Rabita Hall , POF Wah Cantt.

2. GENERAL INSTRUCTIONS REGARDING PREPARATION OF QUOTATIONS

- 2.1 For materials, the prices should be filled in column 5 and delivery date in column 6 of the schedule to this Tender Enquiry. The undertaking should be signed at the bottom of the Schedule which shall form the Quotation. You may use a separate sheet if necessary.
- 2.2 For Plant and Machinery, you are required to quote in two parts:-
Part I "Technical Offer": It should exclusively give technical details and literatures/brochures of the offered plant, machinery and equipment; validity date; delivery schedule; and signed undertaking given on the schedule to this Tender Enquiry. It must not indicate price, costs etc.

Part II "Commercial Offer": It should indicate the commercial terms e.g. price, terms of payment, mode of payment, mode of supply.

Each part should be placed in a separate sealed cover. The envelopes should be inscribed with: Part I "Technical Quotation without Price" and Part II "Commercial Quotation with Price".

- 2.3 The quotation must remain valid for, at least 90 days from the date of open of tenders.
- 2.4 The quotation should hold good for any reduced or enhanced quantities without notice.
- 2.5 In the event of non-acceptance of offer, intimation may be given to the Tenderers on their request.
- 2.6 Conditional offers or alternative offers are likely to be ignored.
- 2.7 Quotations should be based on:-

F.O.R. station of despatch basis, i.e. delivered free on rail, inclusive of packing and forwarding charges. The stores will be booked under Military Credit Note, to be provided by the purchaser.

and/or

Free delivery at POF's stores at WAH CANTT

In this case Octroi duty will be payable by the supplier.

- 2.8 Taxes and Duties etc. where applicable, must be shown separately, quoting references to Registration No. in cases of Sales Tax and relevant authority in the case of others. Offers without these clarifications and inclusive of Taxes and Duties may be ignored.
- 2.9 Taxes and duties levied on or after Tender opening date or on or after the date offer was signed and despatched will be allowed to include in the offered rates.
- 2.10 "Suppliers will furnish a certificate, issued by Excise & Taxation deptt., that he has cleared all Professional Tax payable by him" offers received without this certificate will be rejected.
- 2.11 supplier will render necessary information regarding hazardous effects on environment, of the material/products supplied by them, in their quotations and shipping/despatch documents.
- 2.12 If the requisite information is not furnished on the T.E forms or offer received is not conformity with the requirement of the T.E such offer shall be ignored.

3. INSPECTION

- 3.1 Supplies shall be subject to the inspection and acceptance by the competent inspection authority nominated by the Purchaser, who will arrange it at his own cost. Inspection facilities such as tools, test equipment, instruments etc will, however, be provided by the Suppliers in accordance with the relevant specifications.
- 3.2 Where considered necessary by the Purchaser, stores may be obtained on Warranty/Guarantee, subject to inspection on receipt. Rejected stores will be removed and replaced with the acceptable stores by the Supplier at his own expense, within a specified time.

Contd...P-3

4. TENDER FEE

The tender must be accompanied by a non-refundable fee by means of a crossed postal order/pay order for Rs. 500/- in favour of:

M.D-EXPLOSIVES

4.1 TENDER SAMPLE

Where required, offer must accompany tender sample., strictly according to the description and specification given in Tender Enquiry. Offer not accompanied by tender sample will NOT be entertained excepting the established and reputable firms who have either previously satisfactorily supplied the same or similar stores or have submitted an acceptable sample thereof against previous T.E.

5. BID MONEY

- 5.1 Bid Money at the rate of 2% (for registered firms) and 5% (for unregistered firms) of the quoted value should accompany the tender in the shape of Deposit at Call Receipt/Pay Order/Banker's cheque, from a scheduled Bank drawn in favour of:-

M.D-EXPLOSIVES

Tenders received without Bid Money will be rejected.

- 5.2 Bid Money of the unsuccessful tenderers will be returned as soon as the scrutiny of the tenders is completed. Bid Money of the successful tenderers will be retained until the contract is finalised. Bid Money will be forfeited in case the quotation is withdrawn before the expiry of its validity date.

- 5.3 State owned organizations are not required to provide Bid Money.

6. ACCEPTANCE OF OFFERS

- 6.1 POF may reject all bids or proposals at any time prior to the acceptance of a bid or proposals, but is not required to justify grounds for its rejection. POF Shall incur no liability towards suppliers or contractors who have submitted bids or proposals.

6.2 PERFORMANCE BOND

- (a) The successful bidders shall provide performance bond at the rate, prescribed by POF Board according to the value of contract, which shall not exceed 10% of contract value in the form of Deposit At Call Receipt from a scheduled Bank; or, an un-conditional Bank Gaurantee valid for 12 months (03 months extendable to 12 months in case of cloth items required by Clothing Fy.) after receipt of store in POFs on a prescribed format. The performance Bond will be in favour of CMA(POF) Wah Cantt. It will be returned on satisfactory completion of contract.
- (b) If the Supplier fails to furnish the Performance Bond within the specified time, such failure will constitute a breach of the contract and the Purchaser shall be entitled to make other arrangements for purchase of the stores at the risk and expense of the Supplier.

Contd....p-4

6.3 Performance Bond from State owned organizations may be waived off at the discretion of the Purchaser.

6.4 FAILURE TO SUPPLY THE STORES

All deliveries must be completed by the specified date. In case of failure to deliver the stores within the scheduled time should have arisen from "Force Majeure", which the purchaser may admit as reasonable ground for further time, he will allow such additional time as he may consider to have been required by the circumstances of the case. Otherwise, he will be entitled, at his discretion, to cancel the contract; and/or claim liquidated damages upto 2% but not less than 1% of the contract price of the items and their quantities for each and every month or part of a month, beyond the specified delivery date, during which these may not be delivered, subject to a maximum of 10% of the total contract value; or, to purchase from elsewhere, the unsupplied stores at the risk and cost of the supplier.

6.5 PAYMENT

Payment will be made by the CMA(POF) through crossed cheque on receipt/ acceptance of stores on our prescribed bill form supported by receipt voucher on part/full supply basis.

(a) Payment of duties/Taxes including professional tax (where applicable) must be supported by proof of having paid these to concerned Govt. Taxation Deptt.

7. SECURITY OF INFORMATION

The tenderer and his employees must not communicate any information relating to the sale/purchase of stores under this enquiry to any person other than the manufacturer or to any press or agent not authorised in writing by POFs to receive it.

Please return the Schedule to the Tender duly signed by the specified date, alongwith the specifications, drawings etc. if any, enclosed herewith - even if you are unable to quote.

WARNING In case the firm abstain from making offers or fail to return/ acknowledge the tender form by the specified date on three consecutive occasions, no further tender enquiry may be issued to them and their names would liable to remove from the approved list.

Yours faithfully

(MUHAMMAD AHMAD ARSALAN
MANAGER PURCHASE (X)
EXPLOSIVES FACTORY

URGENT

Tele 0092-51-9055-29216

Fax 0092-51-9271400

PAKISTAN ORDNANCE FACTORIES WAH CANTT**SCHEDULE OF STORE TO BE SUPPLIED AGAINST T.E # 0082-EXP-LP-48, DT. 02-08-2018.**

(1)	(2)	(3)	(4)	(5)		(6)
Item No.	DESCRIPTION OF STORE WITH SPEC.	Unit	Qty	PRICE PER UNIT		Delivery Period
				in word	in figure	
1.	DOUBLE THRUST BALL BEARING (HEAVY SERIES) D-15 HOFFMANN Overall Length : 100 mm (05 Pieces) Make Hoffmann England DRG # POF / E-12/02,03-S/48	No.	04			Within 03 months after placement of contract

2. **For Plant & Machinery:**
Specification

3. **Special Conditions:**

Delivery period is defined as the date of receipt of store in POF duly inspected and accepted by the concerned inspection agency.

- i. Rates and sales Tax must be shown separately otherwise rate will be considered inclusive of G.S.T
- ii. Offer without bid money (CDR) and tender fee will not be considered.
- iii. Date and stamp of postal order must be visible.
- iv. Only registered suppliers with sale tax and Income tax department who are on Active Taxpayers List (ATL) of FBR are eligible to participate in the bid. Documentary proof of the same must be attached with the bid.
- v. The payment to the registered supplier will be linked with the active taxpayer status of the suppliers as per FBR database. If any registered supplier is not in ATL his payment would be stopped till he files his mandatory returns and appears on ATL of FBR.
- vi. Photo copy of NTN and PTC Certificates duly attested by Gazetted Class-I Officer must be attached with the bid. In case, if order is placed on your firm, Professional Tax Certificate issued by the Govt. of Punjab and of the province of your firm will have to be submitted alongwith the bill against supply.
- vii. The store must be protected adequately and appropriately against damages from environmental effects, water or other substances during journey/ transportation to withstand the rough handling involved in the transit and provide preservation of store while held on the storage by the supplier
- viii. Moreover, all the terms and conditions given in T.E general instructions performa from POF 1262 A (indigenous supplies) must be accepted.
- ix. Inspection authority: Manager Q.C (X) or his authorized rep. Place of inspection : Explosives Factory.
- x. Please clearly confirm our specs. Any conditional or alternative offers are likely to be ignored.
- xi. Offer giving any inspection other than specified inspection will not be accepted.
- xii. Supplier must accept all the terms and conditions embodied in POF 1281 (General conditions of contract).
- xiii. Offer of black listed firms will not be entertained.
- xiv. Loading, Lifting, Collection of the rejected store will be firm's responsibility.

4. **UNDERTAKING**

Should our offer be accepted we hereby undertake to supply the stores/render the services contracted on the basis of conditions of contract embodied in form P.O.F.-1281 and to deposit the performance bond within the prescribed time, failing which it will constitute a breach of contract and P.O.F. will have the right to purchase the stores/services elsewhere at our risk and cost.

PLACE.....
DATED.....

SIGNATURE OF THE TENDERER
NAME:.....
POSITION.....
INCOME TAX G.I.R. NO.....

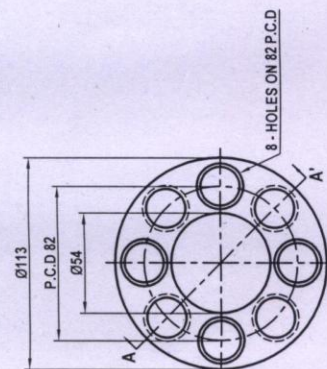

TOP VIEW

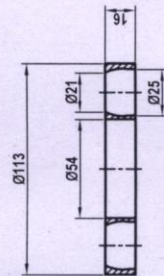

DETAIL OF SECTION A - A'

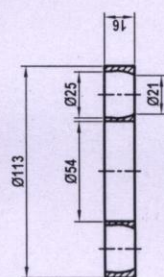

SECTIONAL FRONT VIEW
DETAIL OF PART NO = 02
MATERIAL = BRASS
QTY. NO = 02

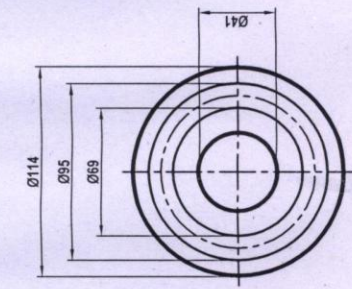

TOP VIEW

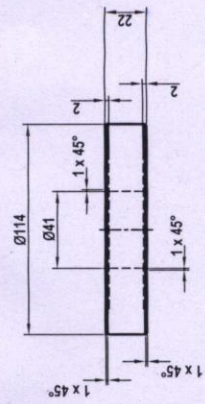

FRONT VIEW
DETAIL OF PART NO = 03

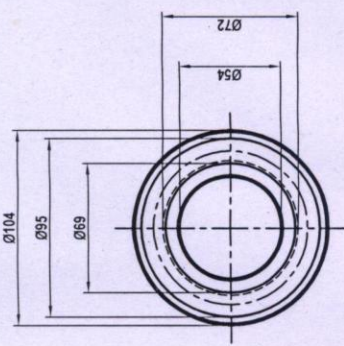

TOP VIEW

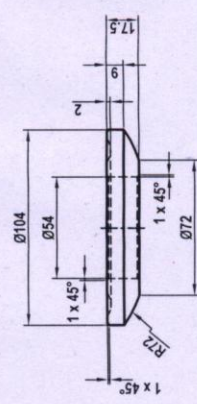

FRONT VIEW
DETAIL OF PART NO = 01
QTY. NO = 02

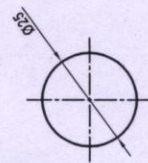

BALLS
DETAIL OF PART NO = 04
QTY. NO = 16

MATERIAL SPECIFICATION
FOR PART NO = 1,3 & 4

C	=	0.98 ~ 1.1
Cr	=	1.30 ~ 1.6
Mn	=	0.25 ~ 0.45
S	=	0.025 ~ MAX
P	=	0.025 ~ MAX
Si	=	0.15 ~ 0.35
Fe	=	BALANCE

CHROME STEEL
SAE 52100

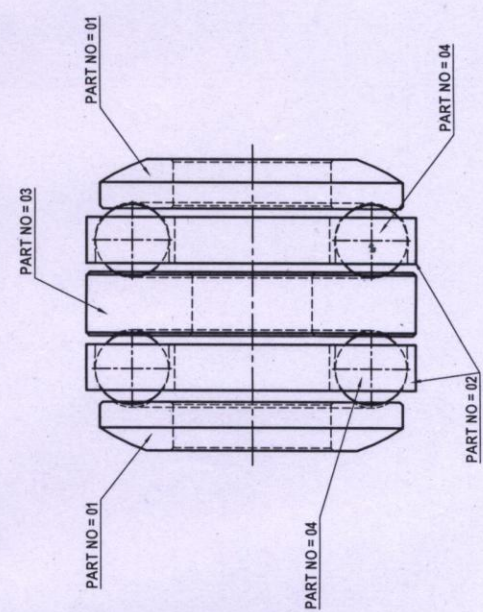

ASSEMBLY

NOTE:-

- 1- FIGURED DIMENSIONS ARE TO BE FOLLOWED
- 2- ALL DIMENSIONS ARE IN M.M
- 3- MACHINE SURFACE ALL OVER
- 4- MATERIAL CHROME STEEL (SAE 52100) OTHERWISE SHOWN

TITLE:-
DETAIL OF DOUBLE DIRECTION THRUST BALL
BEARING (HEAVY SERIES) D-15

DRAWING No.:-
POF/E 12/02.03 - S/56